

# **AIR COMPRESSOR, VACUUM PUMP & LIQUID PUMP**

GENERAL CATALOG

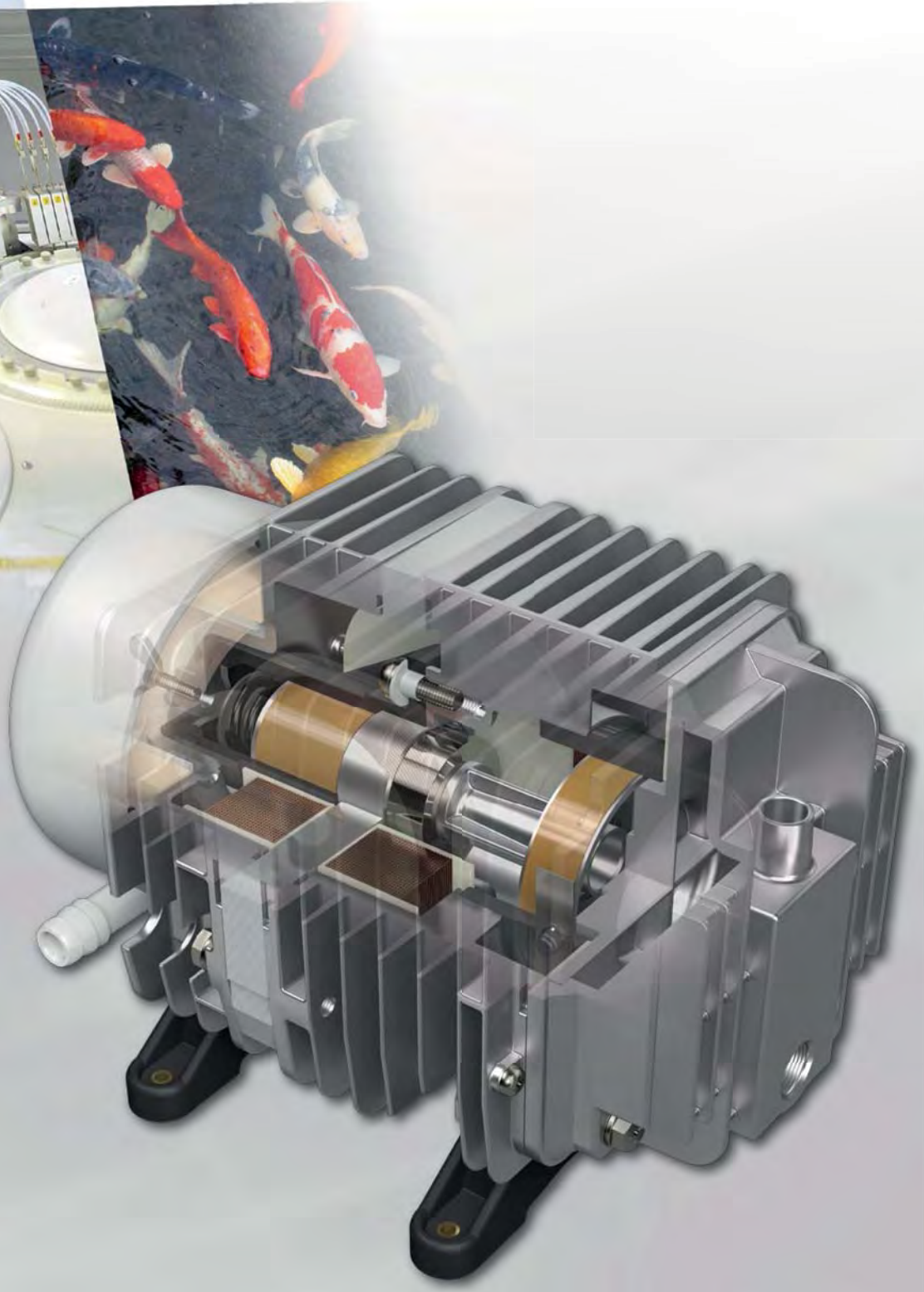
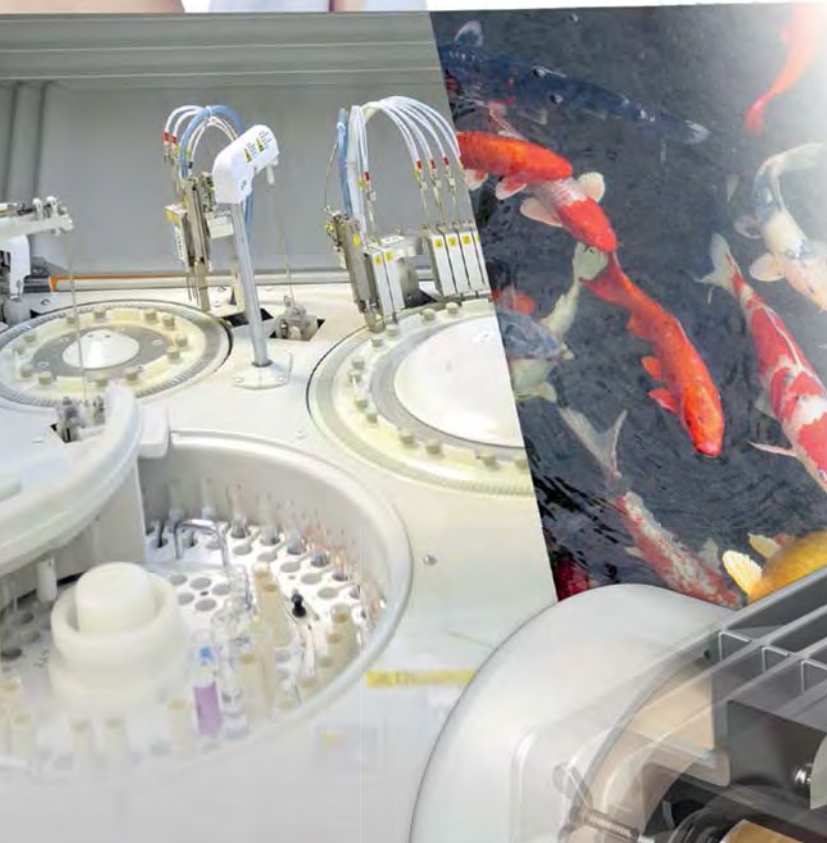

Our air compressors and vacuum pumps are unique products featuring a Linear-motor-driven Free Piston System. Nitto Kohki has made available a complete series of air compressors and vacuum pumps that incorporate this revolutionary mechanism. These are quite appropriate as air sources or vacuum units for various pneumatically operated equipment and apparatus in advanced industries.

## Linear-motor-driven Free Piston Mechanism

The Electro-magnet and return spring alternatively drive the piston inside the cylinder, the mechanical resonance of which is synchronized with the input current cycle. In a single mechanism, the piston combines the functions of two normally independent devices; the pump and the motor.

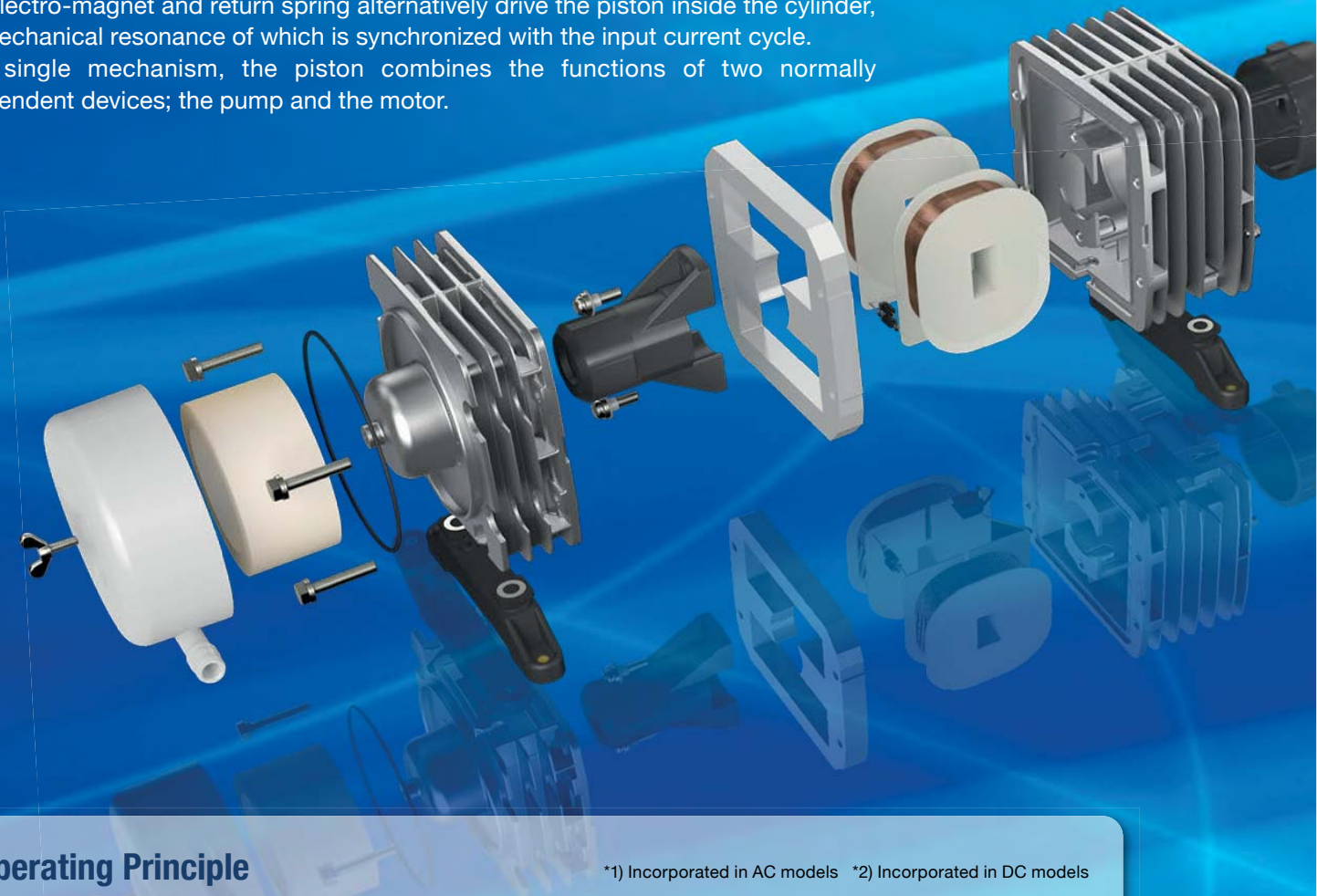

### Operating Principle

\*1) Incorporated in AC models \*2) Incorporated in DC models

A silicon diode<sup>1</sup> in between the coils or inverter<sup>2</sup> converts the full-wave input current into half-rectified current. In turn this activates and deactivates the electro-magnet, producing a smooth mechanically resonating action.

The energized electro-magnet attracts the piston, compresses the return spring, and draws air into the cylinder through the opened inlet valve.

<b>A</b>	<b>AC Power</b> (The effect of using a silicon diode)	<b>DC Power</b> (The effect of using an inverter)	
<b>B</b>			

When the electro-magnet is de-energized, the return spring pushes the piston back, forcing the compressed air out of the cylinder through the now opened outlet valve.

Repeating the movements of A and B delivers the function of compressor or vacuum pump.

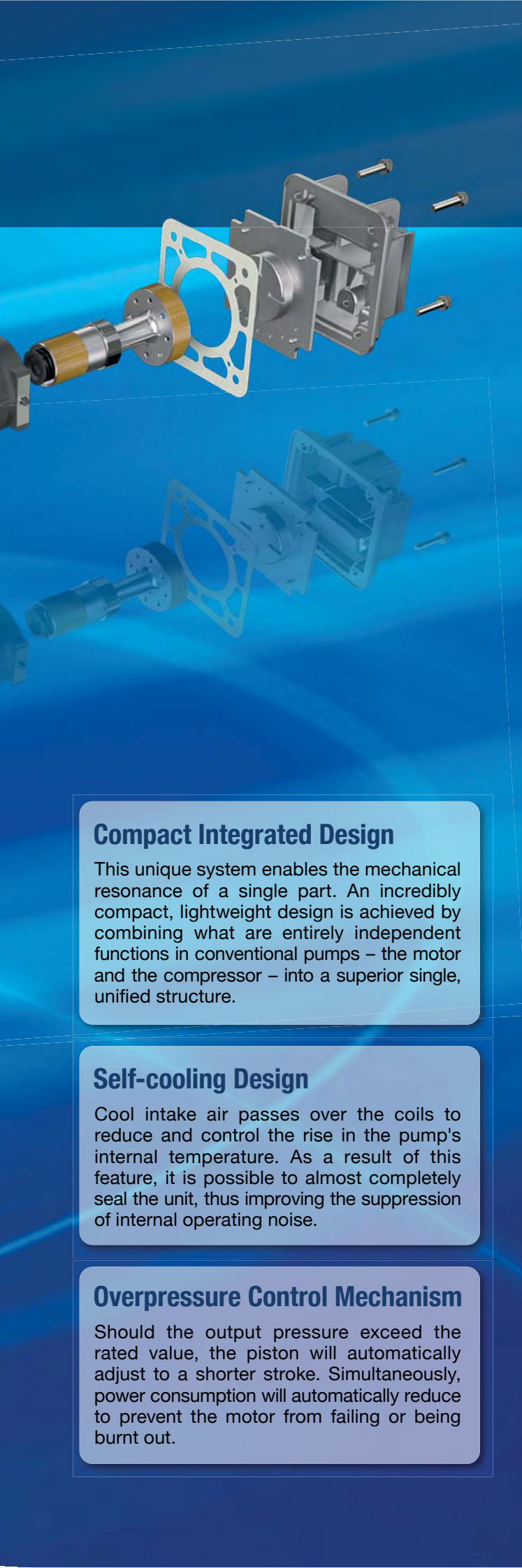

### Compact Integrated Design

This unique system enables the mechanical resonance of a single part. An incredibly compact, lightweight design is achieved by combining what are entirely independent functions in conventional pumps – the motor and the compressor – into a superior single, unified structure.

### Self-cooling Design

Cool intake air passes over the coils to reduce and control the rise in the pump's internal temperature. As a result of this feature, it is possible to almost completely seal the unit, thus improving the suppression of internal operating noise.

### Overpressure Control Mechanism

Should the output pressure exceed the rated value, the piston will automatically adjust to a shorter stroke. Simultaneously, power consumption will automatically reduce to prevent the motor from failing or being burnt out.

# Contents

Page

Series Selection	3
Conversion Tables	6
Explanation of Technical Terms	7
The Key Design Features of the Linear-motor-driven Free Piston System	9
Safety Guide	113

Linear Free Piston	<b>AC Linear Free Piston Compressor</b> AC0102 / AC0201A / AC0301A / AC0401A / AC0602 / AC0901 AC0902 / AC0105 / AC0110 / AC0207 / AC0410A / AC0610 AC0910 / AC0920	10
	<b>AC Linear Free Piston Vacuum Pump</b> VP0125 / VP0140 / VP0435A / VP0450 / VP0625 / VP0660 VP0940 / VP0940T	26
	<b>DC Linear Free Piston Compressor</b> DAH102-X1 / DAH102-Y1 / DAH105-X1 / DAH105-Y1 DAH110-X1 / DAH110-Y1	36
	<b>DC Linear Free Piston Vacuum Pump</b> DVH130-X1 / DVH130-Y1 / DVH145-X1 / DVH145-Y1	44
Diaphragm	<b>AC Linear Diaphragm Pump</b> Dual & Blower Type: VC0100 / VC0101 / VC0201B / VC0301B	50
DC Motor	<b>DC Piston Pump</b> <b>DC Diaphragm Pump</b> DP0105-X1 / DP0105-Y1 / DPA0105-X1 / DPA0105-Y1 / DP0410-X1 DP0410-Y1 / DP0410-X2 / DP0410-Y2 / DP0410T-Y1 / DP0410T-Y2 DP0125 / DP0140 / DP0102 / DP0102S / DP0102H-X1 / DP0102H-X2 DP0110-X1 / DP0110-Y1 / DP0110-X3 / DP0110T-X1 / DP0110T-Y1 DP0210TA-Y1	60
	Liquid Pump	<b>Piezoelectric Pump</b> BPS / BPH / BPHS / BPF Type
		<b>DC Diaphragm Liquid Pump</b> DPE-100 / DPE-400 / DPE-400BL / DPE-800
	<b>AC Linear Free Piston Blower</b> LA-28B / LA-45C / LA-60B / LA-80B / LA-100A / LA-120A / LAM-200	94
	<b>Linicon (Vacuum Pump)</b> LV-125A and Vacuum Pen Assembly	99
	<b>Made to Order Model</b> AC0210/AC0610A / VP0645 / VP0945 / VP0925A / VP0660 x 2 VCK0120 / VC0101E / VC0101S / LAM-150 / Bimor Pump	100
	<b>"CUPLA" Quick Connect Couplings</b>	114

## Green Procurement

NITTO KOHKI has made every effort in developing "Environmental Improvement Plans" through the implementation of ISO14001, to execute environmentally conscious business activities on a company-wide basis. As a part of our ongoing commitment to the environment, we are also committed to reduce and/or exclude restricted substances from our products as designated by RoHS directives, laws and regulations of chemical substances.



# Series Selection

## AC Linear Free Piston Compressor

Model	Rated Pressure		Max. Pressure		Rated Pressure & Max. Pressure	Rated Airflow		Rated Airflow	Page
	kPa	psig	kPa	psig		L/min	cfm		
AC0102	20	2.84	40	5.69		5	0.177		11
AC0201A	10	1.42	20	2.84		20	0.71		12
AC0301A	10	1.42	30	4.27		28	0.99		13
AC0401A	10	1.42	35	4.98		35	1.24		14
AC0602	15	2.13	35	4.98		40	1.41		15
AC0901	10	1.42	40	5.69		80	2.83		16
AC0902	20	2.84	45	6.40		55	1.94		17
AC0105	50	7.11	80	11.4		2.5	0.088		18
AC0110	100	14.2	120	17.1		0.8	0.028		19
AC0207	70	9.96	100	14.2		3.5	0.124		20
AC0210	100	14.2	120	17.1		3.5	0.124		101
AC0410A	100	14.2	130	18.5		5	0.177		21
AC0610/AC0610A	100	14.2	150	21.3		8	0.283		22/102
AC0910	100	14.2	150	21.3		16	0.57		23
AC0920	200	28.4	300	42.7		8	0.283		24

## AC Linear Free Piston Vacuum Pump

Model	Attainable Vacuum	Attainable Vacuum		Free Air Displacement		Free Air Displacement	Page	
		kPa	in.Hg	L/min	cfm			
VP0125		-33.3	-9.84	7	0.247		27	
VP0140		-53.3	-15.7	3	0.106		28	
VP0435A		-46.7	-13.8	25	0.88		29	
VP0450		-66.7	-19.7	18	0.64		30	
VP0625		-33.3	-9.84	40	1.41		31	
VP0660		-80	-23.6	25	0.88		32	
VP0925A		-33.3	-9.84	80	2.83		105	
VP0940		-53.3	-15.7	60	2.12		33	
VP0940T		-53.3	-15.7	120	4.24		34	
VP0645		-60	-17.7	10	0.35		103	
VP0945		-60	-17.7	12	0.42		104	
VP0660x2	Series		-93.3	-27.6	25	0.88		106
	Parallel		-80	-23.6	50	1.77		106

## DC Linear Free Piston Compressor

Model	Rated Pressure		Max. Pressure		Rated Pressure & Max. Pressure	Rated Airflow		Rated Airflow	Page
	kPa	psig	kPa	psig		L/min	cfm		
DAH102-X1	20	2.84	50	7.11		5	0.177		37
DAH102-Y1	20	2.84	50	7.11		5	0.177		38
DAH105-X1	50	7.11	80	11.4		2.5	0.088		39
DAH105-Y1	50	7.11	80	11.4		2.5	0.088		40
DAH110-X1	100	14.2	120	17.1		1.0	0.035		41
DAH110-Y1	100	14.2	120	17.1		1.0	0.035		42

## DC Linear Free Piston Vacuum Pump

Model	Attainable Vacuum	Attainable Vacuum		Free Air Displacement		Free Air Displacement	Page
		kPa	in.Hg	L/min	cfm		
DVH130-X1		-40	-11.8	7	0.247		45
DVH130-Y1		-40	-11.8	7	0.247		46
DVH145-X1		-60	-17.7	3	0.106		47
DVH145-Y1		-60	-17.7	3	0.106		48

### AC Linear Diaphragm Pump (Blower Type)

Model	Rated Pressure		Max. Pressure		Rated Pressure & Max. Pressure				Rated Airflow		Page
	kPa	psig	kPa	psig					L/min	cfm	
VC0100	4	0.57	16	2.28					6	0.212	52
VC0101	10	1.42	20	2.84					10	0.35	54
VC0101E	10	1.42	20	2.84					15	0.53	109
VC0101S	5	0.71	26	3.70					15	0.53	55
VC0201B	10	1.42	18	2.56					20	0.71	57
VC0301B	10	1.42	20	2.84					25	0.88	59

0 50 100 150 200 250 300(kPa)      0 20 40 60 80 100 120 (L/min)

### AC Linear Diaphragm Pump (Dual Type)

Model	Attainable Vacuum	Attainable Vacuum		Rated Pressure		Max. Pressure		Rated Pressure & Max. Pressure				Rated Airflow		Page
		kPa	in.Hg	kPa	psig	kPa	psig					L/min	cfm	
VC0100		-14.7	-4.33	4	0.57	16	2.28					6	0.212	51
VC0101 120 V		-18.7	-5.51	10	1.42	18	2.56					10	0.35	53
VC0101 230 V		-10	-2.95	10	1.42	15	2.13					10	0.35	53
VC0101E		-18.7	-5.51	10	1.42	20	2.84					15	0.53	108
VC0101S		-24	-7.09	5	0.71	26	3.70					15	0.53	110
VC0201B		-18.7	-5.51	10	1.42	18	2.56					20	0.71	56
VC0301B		-21.3	-6.30	10	1.42	20	2.84					25	0.88	58
VCK0120 (Vacuum only)		-26.7	-7.87									18*	0.64*	107

(kPa)-80 -60 -40 -20 0      0 50 100 150 (kPa)      0 20 40 60 (L/min)

\*Free Air Displacement

### DC Liquid Pump

Model	Working Pressure Range		Working Pressure Range	Flow Rate	Flow Rate	Self-priming Pressure		Self-priming Pressure	Page
	kPa	psig				kPa	psig		
DPE-100	0 to 100	0 to 14.2		100		20	2.84		89
DPE-400	0 to 100	0 to 14.2		400		40	5.69		90
DPE-400BL	0 to 100	0 to 14.2		400		40	5.69		91
DPE-800	0 to 100	0 to 14.2		800		40	5.69		92

(kPa) 0 20 40 60 80 100      (mL/min) 0 200 400 600 800      (kPa) 0 20 40 60

\*Test conditions: Water at 25 degrees C

### DC Linear Compressor and Vacuum Pump (Dual Type)

Model	Attainable Vacuum	Attainable Vacuum		Max. Pressure		Free Air Displacement		Free Air Displacement	Page
		kPa	in.Hg	kPa	psig	L/min	cfm		
DP0125		-33.3	-9.84	30	4.27	2.5	0.088		71
DP0140		-53.3	-15.7	50	7.11	4	0.141		72
DP0102		-26.7	-7.87	45	6.40	5	0.177		73
DP0102S		-26.7	-7.87	45	6.40	7	0.247		74
DP0102H-X1		-50.7	-15.0	80	11.4	4	0.141		75
DP0110-X1		-66.7	-19.7	150	21.3	7.5	0.265		77
DP0110-Y1		-66.7	-19.7	150	21.3	7.5	0.265		78
DP0110-X3		-66.7	-19.7	150	21.3	7.5	0.265		79
DP0110T-X1		-60	-17.7	150	21.3	5.5	0.194		80
DP0110T-Y1		-60	-17.7	150	21.3	5.5	0.194		81
DP0210TA-Y1		-60	-17.7	150	21.3	10	0.35		82
DP0105-X1		-66.7	-19.7	250	35.6	2.8	0.099		61
DP0105-Y1		-66.7	-19.7	250	35.6	2.8	0.099		62

(kPa)-80 -60 -40 -20 0 0 50 100 150 200 250(kPa) 0 20 40 60(L/min)

### DC Linear Compressor only

Model	Attainable Vacuum	Attainable Vacuum		Max. Pressure		Free Air Displacement		Free Air Displacement	Page
		kPa	in.Hg	kPa	psig	L/min	cfm		
DP0102H-X2				80	11.4	4	0.141		76
DPA0105-X1				220	31.3	2.8	0.099		63
DPA0105-Y1				220	31.3	2.8	0.099		64
DP0410-X2				180	25.6	18	0.64		67
DP0410-Y2				180	25.6	18	0.64		68
DP0410T-Y2				150	21.3	34	1.2		70

(kPa)-80 -60 -40 -20 0 0 50 100 150 200 250(kPa) 0 20 40 60(L/min)

### DC Vacuum Pump only

Model	Attainable Vacuum	Attainable Vacuum		Max. Pressure		Free Air Displacement		Free Air Displacement	Page
		kPa	in.Hg	kPa	psig	L/min	cfm		
DP0410-X1		-77.3	-22.8			18	0.64		65
DP0410-Y1		-77.3	-22.8			18	0.64		66
DP0410T-Y1		-77.3	-22.8			34	1.2		69

(kPa)-80 -60 -40 -20 0 0 50 100 150 200 250(kPa) 0 20 40 60(L/min)

# Conversion Tables

## Pressure / Flow Rate / Vacuum

### Pressure

kPa	kgf/cm <sup>2</sup> (bar)	psig
300	3.0	42.7
280	2.8	39.8
250	2.5	35.6
200	2.0	28.5
180	1.8	25.6
150	1.5	21.3
120	1.2	17.1
<b>100</b>	<b>1.0</b>	<b>14.2</b>
80	0.8	11.4
70	0.7	9.96
50	0.5	7.11
45	0.45	6.40
40	0.4	5.69
35	0.35	4.98
34	0.34	4.84
30	0.3	4.27
20	0.2	2.84
18	0.18	2.56
15	0.15	2.13
11	0.11	1.56
10	0.1	1.42
<b>7</b>	<b>0.07</b>	<b>1.00</b>
5	0.05	0.71
1	0.01	0.142
* 0	0	0

### Flow Rate

cfm	L/min	cfm	L/min
<b>0.035</b>	<b>1.00</b>	2.12	60.0
0.070	2.00	2.25	63.7
0.100	2.83	2.47	70.0
0.105	3.00	2.50	70.8
0.177	5.00	2.65	75.0
0.250	7.08	2.75	77.9
0.353	10.0	2.83	80.0
0.500	14.2	3.00	85.0
0.530	15.0	3.18	90.0
0.708	20.0	3.25	92.0
0.750	21.2	3.50	99.1
0.883	25.0	3.53	100
<b>1.00</b>	<b>28.32</b>	3.75	106
1.06	30.0	3.89	110
1.24	35.0	4.00	113
1.25	35.4	4.24	120
1.41	40.0	4.50	127
1.50	42.5	5.00	142
1.59	45.0	5.30	150
1.75	49.6	6.00	170
1.77	50.0	7.00	198
2.00	56.6	7.06	200

### Vacuum

kPa	mmHg	mbar	in.Hg
* 0	0	0	0
-13.3	-100	-133	-3.94
-26.7	-200	-267	-7.87
-33.3	-250	-333	-9.84
-44.0	-330	-440	-13.0
-45.3	-340	-453	-13.4
-46.7	-350	-467	-13.8
-53.3	-400	-533	-15.7
-60.0	-450	-600	-17.7
-66.7	-500	-667	-19.7
-73.3	-550	-733	-21.7
-80.0	-600	-800	-23.6
-93.3	-700	-933	-27.6
-100	-750	-1000	-29.5
** -101.3	-760	-1013	-29.9

### Pressure

from \ to	kPa	kgf/cm <sup>2</sup>	bar	psig
kPa	1	0.01	0.01	0.142
kgf/cm <sup>2</sup>	100	1	1	14.2
bar	100	1	1	14.2
psig	7	0.07	0.07	1

### Vacuum

from \ to	kPa	mmHg	in.Hg	mbar
kPa	-1	-7.50	-0.295	-10
mmHg	-0.133	-1	-0.0394	-1.335
in. Hg	-3.39	-25.4	-1	-33.92
mbar	-0.1	-0.75	-0.0295	-1

\* Gauge pressure  
 \*\* Absolute vacuum

# Explanation of Technical Terms

Be sure to read the following “Explanation of Technical Terms” before selecting a model appropriate for your application.

## Application Examples and Applicable Fluids for Compressors and Vacuum Pumps

**Application:** for incorporation into equipment    **Applicable fluid:** Air

### For Compressors & Vacuum Pumps

**Rated performance:** The average total accumulated time over which the unit can be used without repair, except the maintenance of the filter. This indicates the expected time required for the rated air flow to fall to 80% of the specification value in the rated operation. The actual life might vary depending on the actual operating and environmental conditions such as output pressure setting, maintenance schedule, ventilation, ambient temperature, duty cycle, etc.

**MTTF:** MTTF (Mean Time to Failure) is the average time that the product will function before it fails. However, this time is reference only and does not guarantee. Since MTTF depends on your actual operating environment and conditions, conduct performance evaluation test with an actual product prior to use.

**Rated voltage:** The two major types are 115 V AC/60 Hz and 230 V AC/50 Hz (excluding DC motors). While most models can be operated at both 50 Hz and 60 Hz with different performance characteristics, there are some models that are frequency specific.

**Duty cycle:** The period of operation under the condition that the coil temperature will not exceed the coil insulation class limit.

**Rated frequency:** In the case of AC drive pumps, the rated frequency will vary according to the model. While some are designed for only 50 Hz or for 60 Hz, some are designed for both 50 Hz and 60 Hz.

**Coil insulations:** The suggested class, most bare units attaining “E” class, is based on Japanese electric regulations. They are merely suggestions since bare units are considered “components” and are not classified as complete products or systems.

Coil Insulation Class(for reference only)	(Temperature limit, degrees C)
A	100
E	115
B	125
F	150

**Control method:** Be careful when controlling compressors and vacuum pumps with electronic components because the power factor depends upon the load.

**Outside & mounting dimensions:** Useful for assessing the required space for installation. Include sufficient space surrounding the pump when designing it into your application.

**Operating ambient temperature:** 0 to 40°C

**Operating ambient humidity:** 30 to 85% non-condensing

**Storage environment temperature:** -10 to 60°C

**Storage environment humidity:** 10 to 90% non-condensing

### Improvement Suggestion

Our compressors and vacuum pumps employ a unique internal coil cooling feature to reduce or control the rise in internal temperature. If they are operated at higher than rated pressures, elevated temperatures may result. Should these temperatures become excessive, operating duty cycles may need to be reduced, or the use of an auxiliary cooling fan should be considered.



### For Compressors

<b>Rated pressure:</b>	This is the pressure point where you will get optimum capabilities for performance and service life and where the pump is designed to have almost the same airflow regardless of a rated frequency of 50 Hz or 60 Hz.
<b>Rated airflow:</b>	The discharge airflow volume at the rated pressure.
<b>Rated operation:</b>	Operating conditions regarding the rated pressure, rated voltage, and rated frequency.
<b>Maximum pressure:</b>	The highest obtainable pressure at which the pump is designed to operate while producing zero discharge airflow (not guaranteed; for reference only).
<b>Power consumption:</b>	The wattage during operation at the rated pressure.
<b>Electric current:</b>	The electric current during operation at the rated pressure (for reference only).
<b>Airflow characteristics:</b>	Discharge pressure-airflow curve (for reference only).
<b>Power consumption characteristics:</b>	Discharge pressure-power consumption curve (for reference only).

### For Vacuum Pumps

<b>Attainable vacuum :</b>	The highest vacuum the pump can attain with the pump inlet closed (except some of the exclusive models). *The degree of vacuum shown in this catalog is gauge pressure.
<b>Free air displacement:</b>	The airflow volume at zero vacuum (within three (3) minutes after starting).
<b>Power consumption:</b>	The maximum wattage on the power consumption curve when measured against vacuum levels up to the pumps attainable vacuum.
<b>Electric current:</b>	The maximum electric current on the current characteristics curve when measured against vacuum levels up to the pumps attainable vacuum. (for reference only).
<b>Airflow characteristics:</b>	Vacuum-airflow curve (for reference only).
<b>Power consumption characteristics:</b>	Vacuum-power consumption curve (for reference only).
<b>Exhaust characteristics:</b>	The time required to attain the respective vacuum in a 10 liter container (for reference only).

### For DC Pumps

<b>Operating ambient temperature:</b>	0 to 40°C (5 to 50°C for DP0105 only)
<b>Operating ambient humidity:</b>	30 to 85% non-condensing

Start-up the pump at the same level as the atmospheric pressure (Similarly in the case of DPE series pumps)

### For Liquid Pumps

<b>Self-priming pressure:</b>	The power the pump requires to draw up 25°C water. 1 kPa is equal to the power needed to draw up 25°C water 10 cm.
-------------------------------	--

This catalog will give the guidelines needed to determine the appropriate model for your application(s). However, in certain cases you may need further detailed information, which will be provided in the form of a specifications sheet for each model/version by our technical staff who will further assist you in your selection.

**Specifications and designs are subject to change at any time without notice.**

**It is recommended that OEM customers confirm the required specifications in writing before placing orders.**

Experience gained in designing, engineering, manufacturing and continually perfecting our products in thousands of applications has resulted in a “functionally intelligent” package. Please review these key design features and see how every design element contributes overall to the creation of a superior compressor or vacuum pump.

## The Key Design Features of the Linear-motor-driven Free Piston System

<p><b>Compact and Lightweight</b> With the motor and compressor combined into the single structure</p>  <p>With the piston as the only moving part, efficient space utilization enables our pump to be considerably smaller and lighter than other pumps. This allows the OEM design engineer increased packaging options for other internal components.</p>	<p><b>Low Vibration</b> Using an ultra-lightweight piston</p>  <p>Reducing the moving parts to only the piston minimizes reactive force vibrations to the pump body. In addition, the secondary vibrations are isolated or absorbed through the anti-vibration rubber feet.</p>
<p><b>Low Noise Level</b> No transmission assemblies, means less noise</p>  <p>With no need for complicated transmission mechanisms riding on ball bearings, or actuating linkages creating friction and noise, NITTO KOHKI's pumps are inherently quieter. Additionally, the almost completely sealed configuration further suppresses secondary internal operating noises.</p>	<p><b>Clean Operation – Clean Air</b> Due to oil-less construction</p>  <p>All wearing surfaces use no oil, grease or other contaminating lubricants. The combination of a precision fluoropolymer sleeved piston assisted by an “air-bearing effect” made possible through a unique air path design, assures that the outlet air is completely free of oil.</p>
<p><b>Low Power Consumption</b> Truly energy efficient through integrated design</p>  <p>Since the low mass piston is the only moving part, frictional losses are minimized, allowing lower starting and running current, and thus greater efficiency. Related benefits are realized through a lower rise in temperature, facilitating a longer operating life for the pump and the other components within your system.</p>	<p><b>Overload Protection Structure</b> Protects against burnout</p>  <p>As the pressure within the compressor increases, the piston stroke decreases. Along with this, electric current decreases. Thus a temporary overload will not cause a failure or the pump to burnout.</p>
<p><b>Minimal Pulsating Effect</b> Due to the ideal piston stroke</p>  <p>The piston's mechanical resonance speed is synchronized with the input power frequency regardless of the load, i.e., 3000 strokes at 50 Hz, and 3600 strokes at 60 Hz per minute. This high speed produces shorter pulses which translate into a smoother, more uniform and “linear” motion.</p>	<p><b>Instant Response</b> Enabling easy start-ups in frequent on-off short cycle applications</p>  <p>A very low starting current enables our pumps to produce immediate performance in quick short cycle applications, even in the presence of residual back pressure.</p>
<p><b>Easy Maintenance</b> Only air filter and piston to change</p>  <p>The oil-less construction requires no lubrication. A simple mechanism containing the piston as the only moving part causes no failure or burning due to an overload and provides stable performance over a long period of time.</p>	<p><b>Longer Lifetime</b> Increased OEM value</p>  <p>All key design features listed here combine to provide superior performance in all the important aspects of superior pump design. This enables the OEM engineer to have complete confidence in incorporating the unit into the most demanding systems, in the most advanced equipment.</p>

# AIR COMPRESSOR

**AC series**  
Low pressure

**AC series**  
Intermediate pressure

AC0102	—	11
AC0201A	—	12
AC0301A	—	13
AC0401A	—	14
AC0602	—	15
AC0901	—	16
AC0902	—	17

AC0105	—	18
AC0110	—	19
AC0207	—	20
AC0410A	—	21
AC0610	—	22
AC0910	—	23
AC0920	—	24

**Made to Order**

AC0210	—	101
AC0610A	—	102

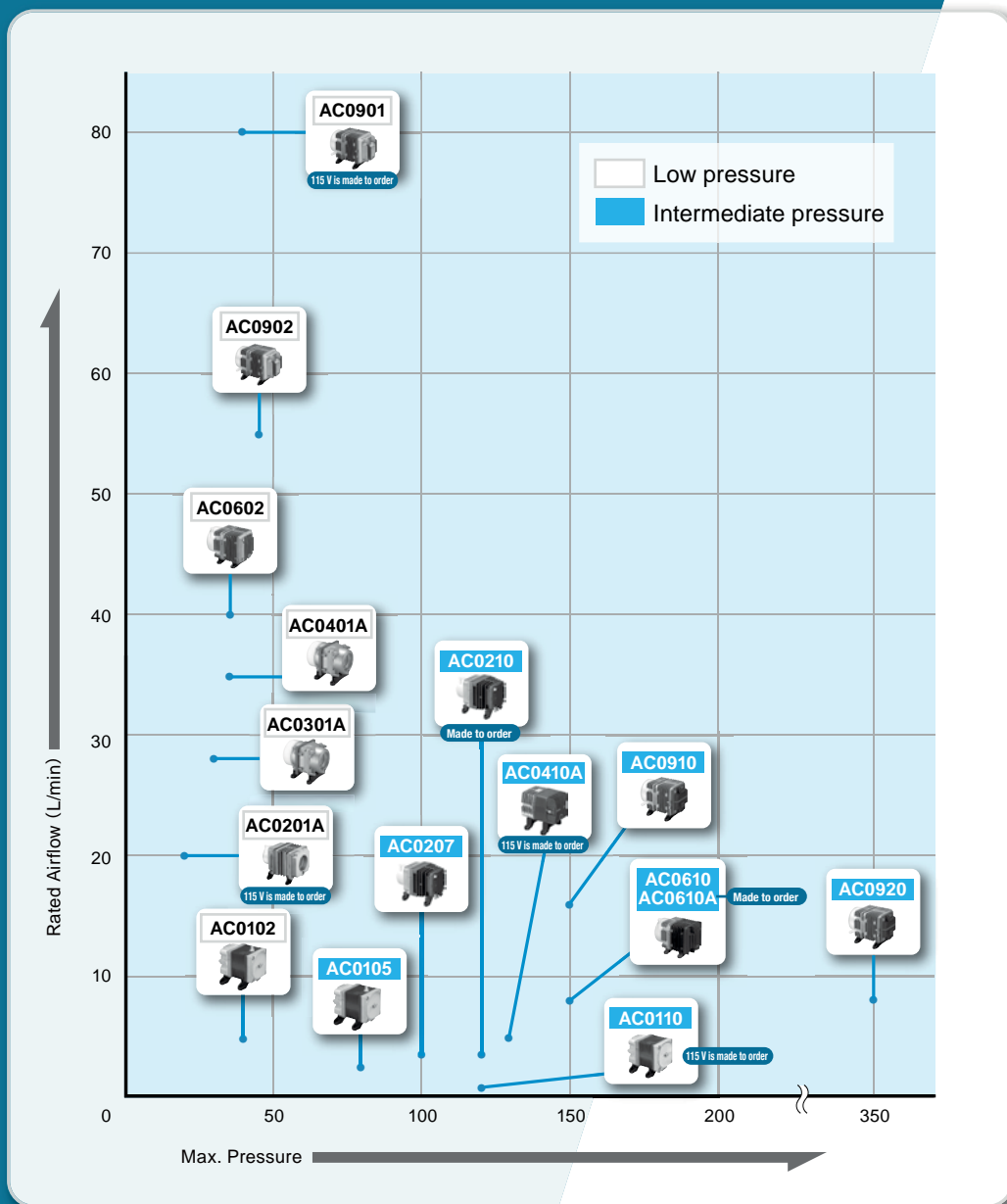

# Compressor

## Model AC0102

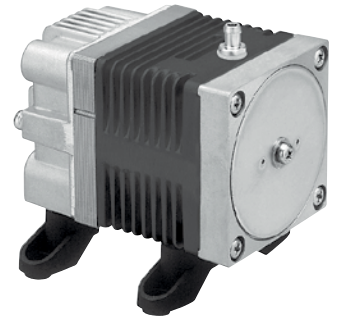

### Airflow & Power Consumption

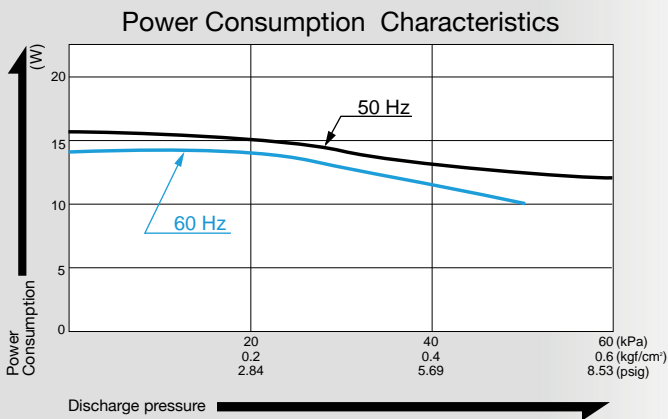
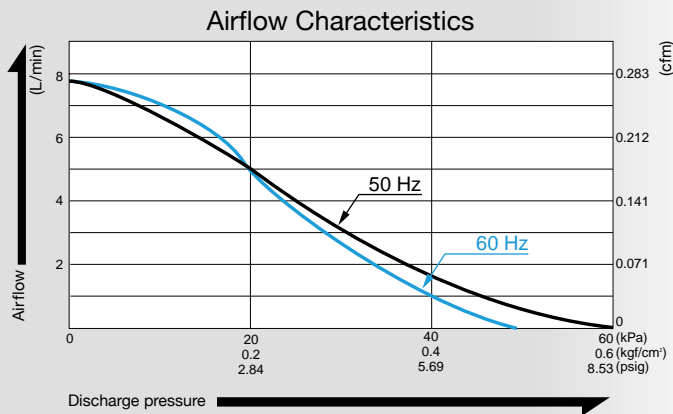

### Specifications

Rated Pressure	20 kPa (0.2 kgf/cm <sup>2</sup> ) 0.2 bar 2.84 psig	
Rated Airflow	5 L/min 0.177 cfm	
Maximum Pressure	40 kPa (0.4 kgf/cm <sup>2</sup> ) 0.4 bar 5.69 psig	
Rated Voltage	115 V AC	230 V AC
Power Consumption	14 W	15 W
Rated Frequency	60 Hz	50 Hz
Rated Performance (MTTF)	10,000 hours	
Outlet	6 mm O.D. hose barb	
Duty Cycle	Continuous	
Coil Insulation Class	Class B for UL	
Mounting Dimensions	48 (L) x 62 (W) mm 1 - 57/64" (L) x 2 - 7/16" (W)	
Weight	0.7 kg 1.54 Lbs	
Leadwire Length	200 mm 7 - 7/8"	

### Application Examples

Dripping Machine

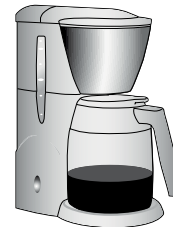

Blood Pressure Tester



### External Dimensions (Unit: mm)

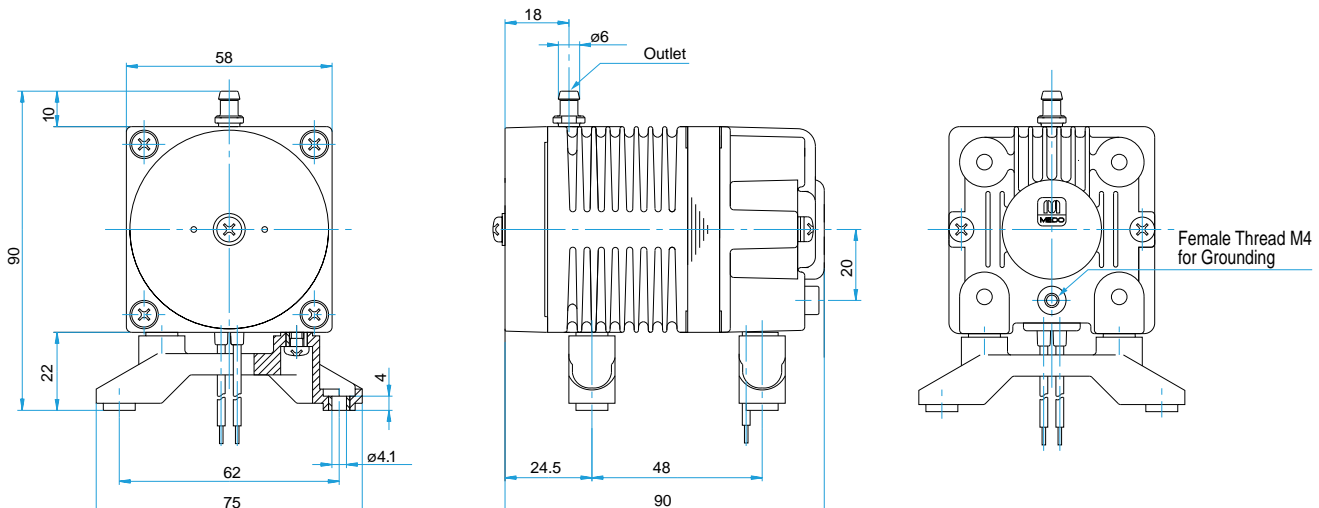

# Compressor

## Model **ACO201A**

115 V is made to order

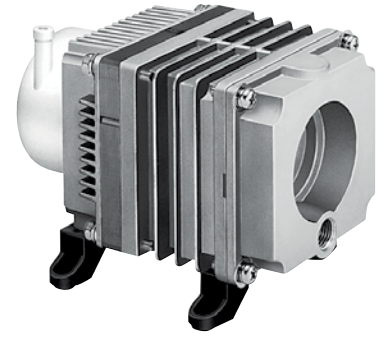

### Airflow & Power Consumption

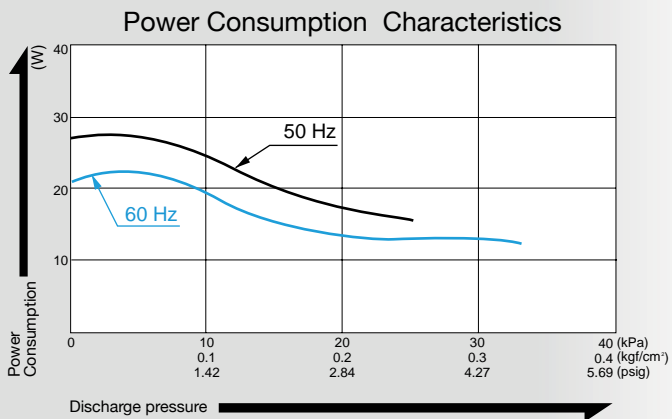
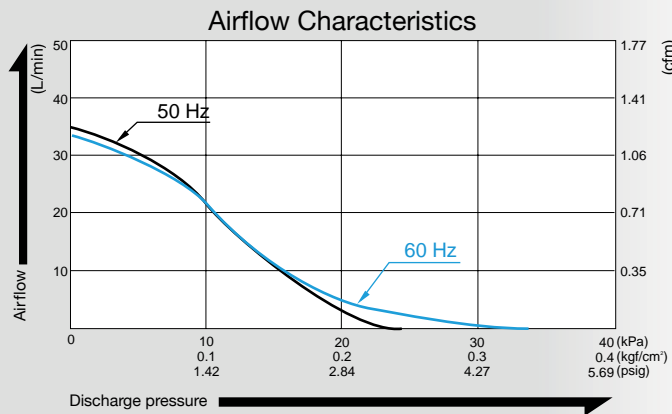

### Specifications

Rated Pressure	10 kPa (0.1 kgf/cm <sup>2</sup> ) 0.1 bar 1.42 psig	
Rated Airflow	20 L/min 0.71 cfm	
Maximum Pressure	20 kPa (0.2 kgf/cm <sup>2</sup> ) 0.2 bar 2.84 psig	
Rated Voltage	115 V AC	230 V AC
Power Consumption	19 W	23 W
Rated Frequency	60 Hz	50 Hz
Rated Performance	6,000 hours	
Outlet	ISO Rc 1/4	
Duty Cycle	Continuous	
Coil Insulation Class	E or its equivalent and B for UL	
Mounting Dimensions	73 (L) x 88 (W) mm 2 - 7/8" (L) x 3 - 15/32" (W)	
Weight	1.5 kg 3.3 Lbs	
Leadwire Length	200 mm 7 - 7/8"	

### Application Examples

#### Seat Lifter

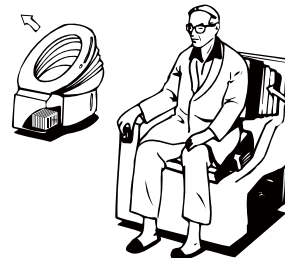

#### Bed Sore Prevention Mattress



### External Dimensions (Unit: mm)

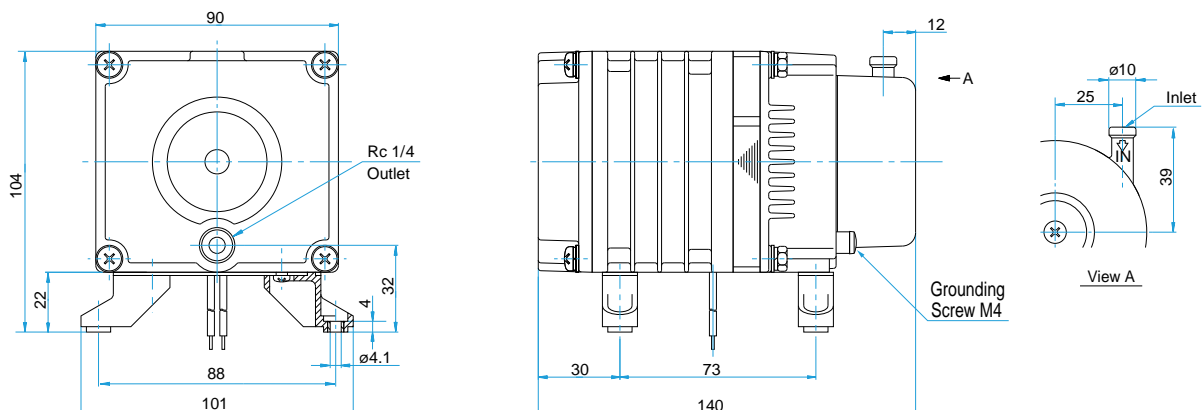





# Compressor

## Model AC0602

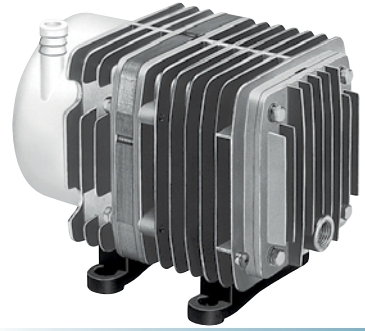

### Airflow & Power Consumption

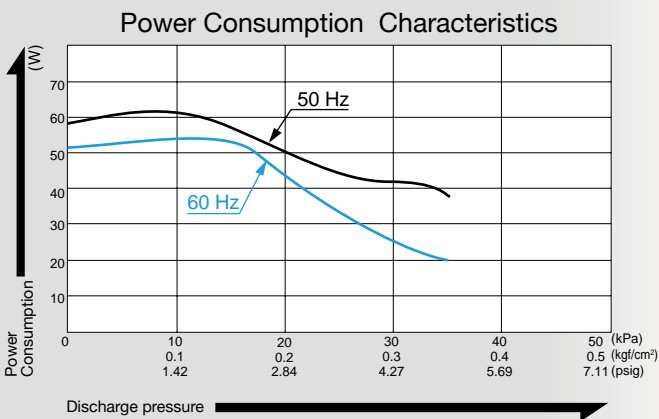
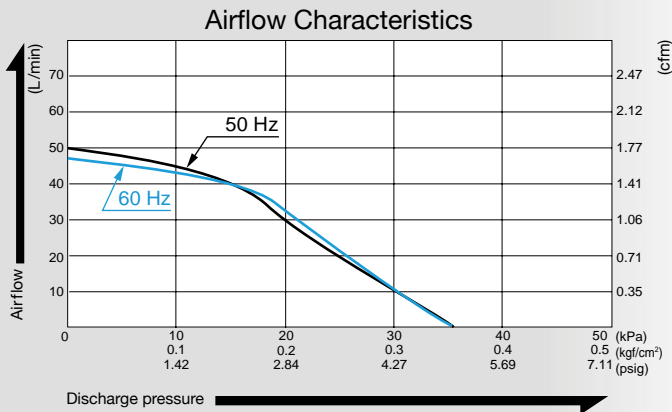

### Specifications

Rated Pressure	15 kPa (0.15 kgf/cm <sup>2</sup> ) 0.15 bar 2.13 psig	
Rated Airflow	40 L/min 1.41 cfm	
Maximum Pressure	35 kPa (0.35 kgf/cm <sup>2</sup> ) 0.35 bar 4.98 psig	
Rated Voltage	115 V AC	230 V AC
Power Consumption	52 W	58 W
Rated Frequency	60 Hz	50 Hz
Rated Performance	10,000 hours	
Outlet	ISO Rc 1/4	
Duty Cycle	Continuous	
Coil Insulation Class	E or its equivalent and A for UL	
Mounting Dimensions	68 (L) x 84 (W) mm 2 - 43/64" (L) x 3 - 5/16" (W)	
Weight	3 kg 6.6 Lbs	
Leadwire Length	235 mm 9 - 1/4"	350 mm 13 - 25/32"

### Application Examples

Air Blaster for Bandsaw

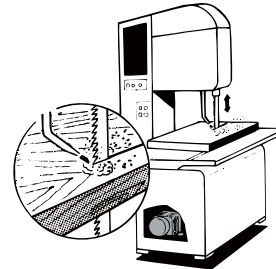

Clean Room Ventilation

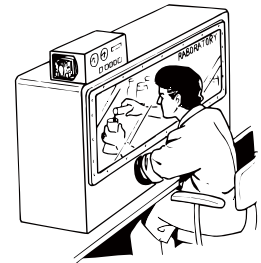

### External Dimensions (Unit: mm)

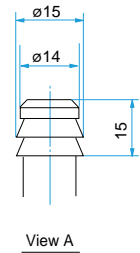
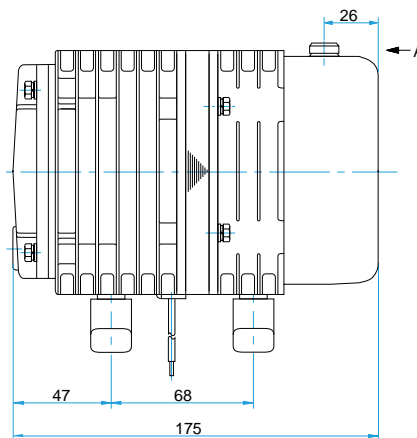
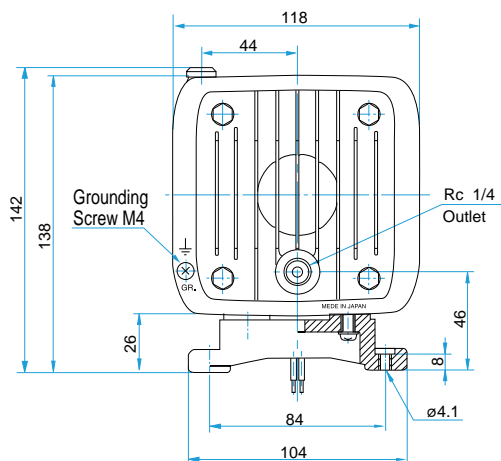



# Compressor

## Model AC0901

115 V is made to order

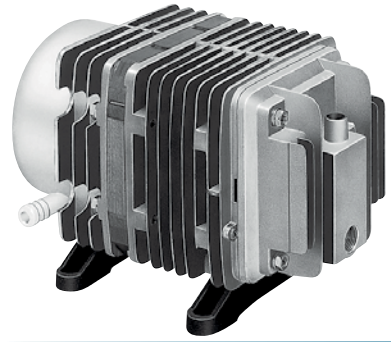

### Airflow & Power Consumption

Airflow Characteristics

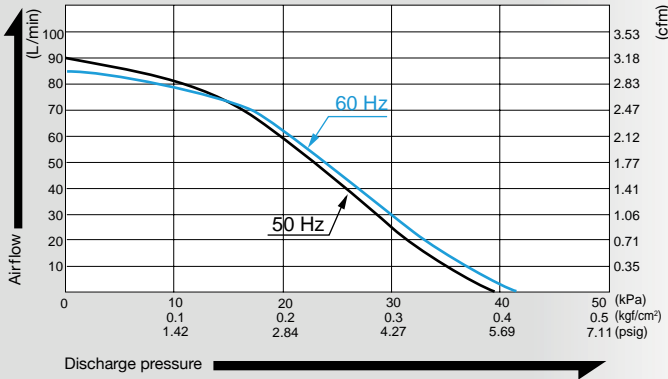

Power Consumption Characteristics

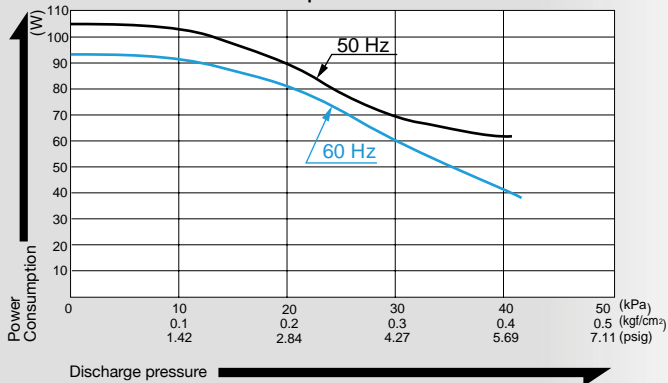

### Specifications

Rated Pressure	10 kPa (0.1 kgf/cm <sup>2</sup> ) 0.1 bar 1.42 psig	
Rated Airflow	80 L/min 2.83 cfm	
Maximum Pressure	40 kPa (0.4 kgf/cm <sup>2</sup> ) 0.4 bar 5.69 psig	
Rated Voltage	120 V AC	230 V AC
Power Consumption	88 W	99 W
Rated Frequency	60 Hz	50 Hz
Rated Performance	10,000 hours	
Outlet	ISO Rc 3/8	
Duty Cycle	Continuous	
Coil Insulation Class	E or its equivalent and B for UL	
Mounting Dimensions	102 (L) x 130 (W) mm 4 - 1/64" (L) x 5 - 1/8" (W)	
Weight	4.9 kg 10.8 Lbs	
Leadwire Length	300 mm 11 - 13/16"	

### Application Examples

Air Lifter for Bathtub

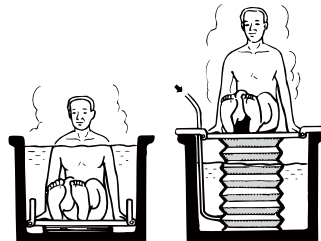

Liquid Dispenser

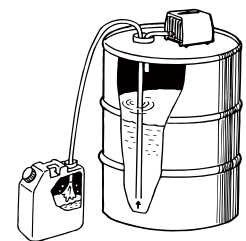

### External Dimensions (Unit: mm)

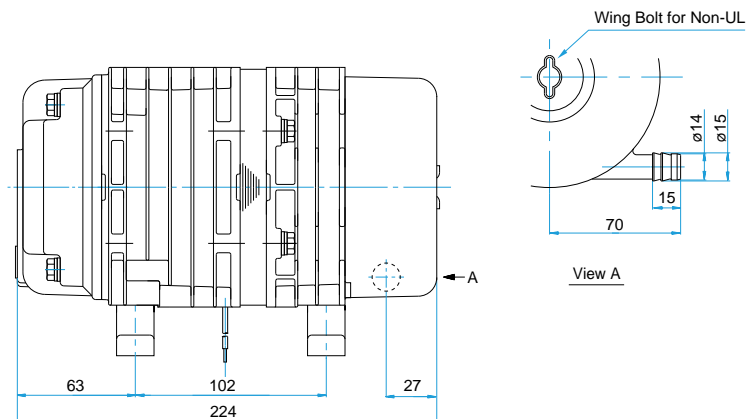
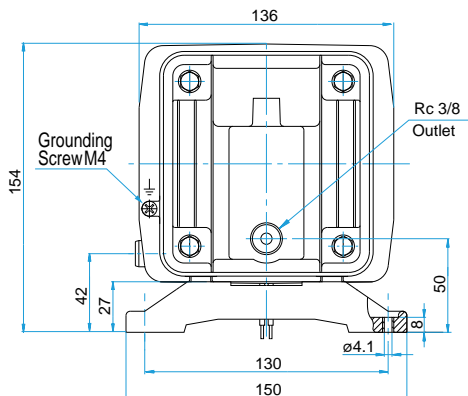

# Compressor

## Model AC0902

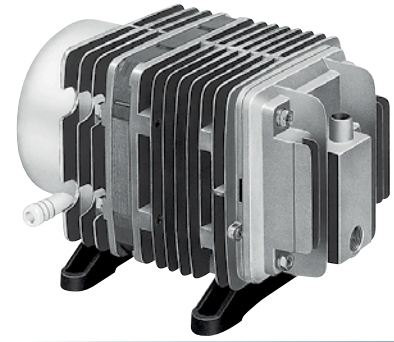

### Airflow & Power Consumption

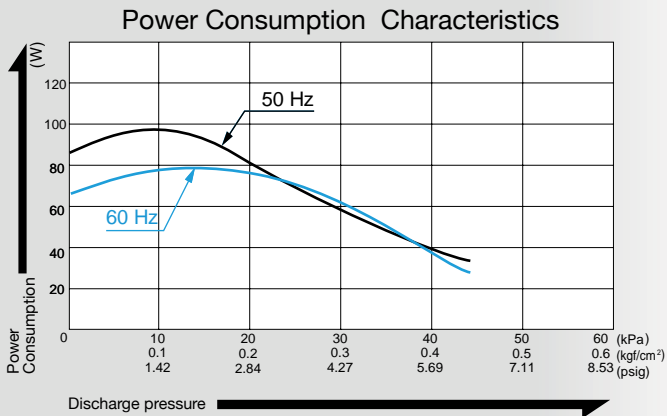
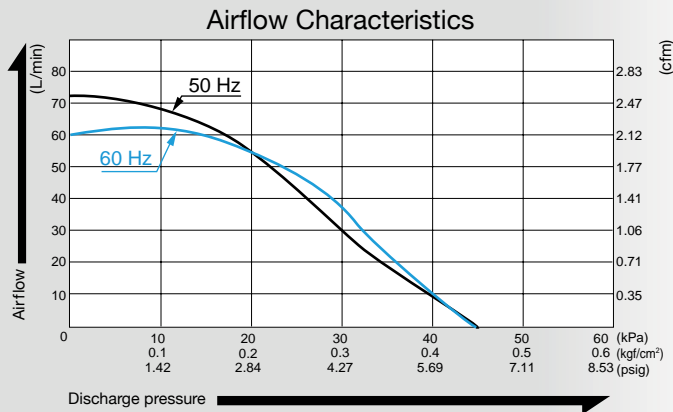

### Specifications

Rated Pressure	20 kPa (0.2 kgf/cm <sup>2</sup> ) 0.2 bar 2.84 psig	
Rated Airflow	55 L/min 1.94 cfm	
Maximum Pressure	45 kPa (0.45 kgf/cm <sup>2</sup> ) 0.45 bar 6.40 psig	
Rated Voltage	115 V AC	230 V AC
Power Consumption	75 W	85 W
Rated Frequency	60 Hz	50 Hz
Rated Performance	10,000 hours	
Outlet	ISO Rc 3/8	
Duty Cycle	Continuous	
Coil Insulation Class	E or its equivalent and B for UL	
Mounting Dimensions	102 (L) x 130 (W) mm 4 - 1/64" (L) x 5 - 1/8" (W)	
Weight	4.9 kg 10.8 Lbs	
Leadwire Length	300 mm 11 - 13/16"	320 mm 12 - 19/32"

### Application Examples

Air Lifter for Bathtub

Liquid Dispenser

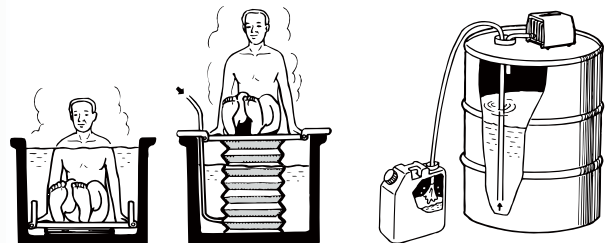

### External Dimensions (Unit: mm)

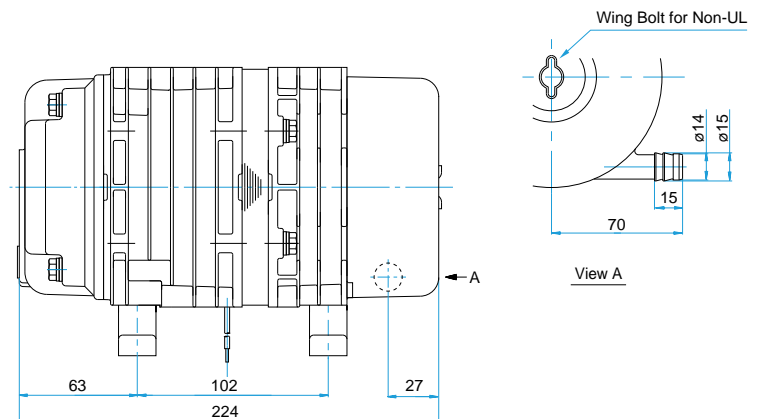
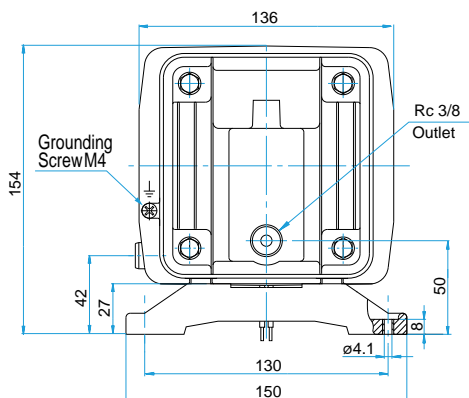

# Compressor

## Model AC0105

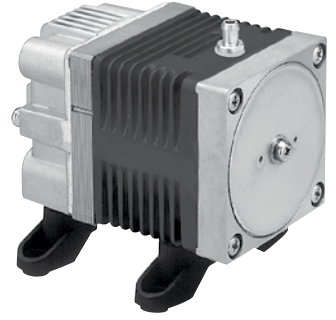

### Airflow & Power Consumption

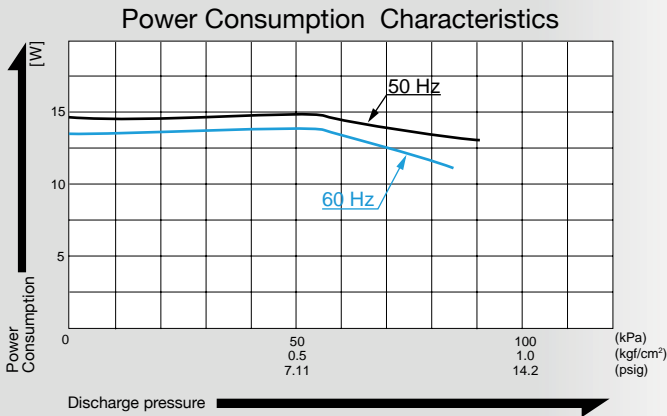
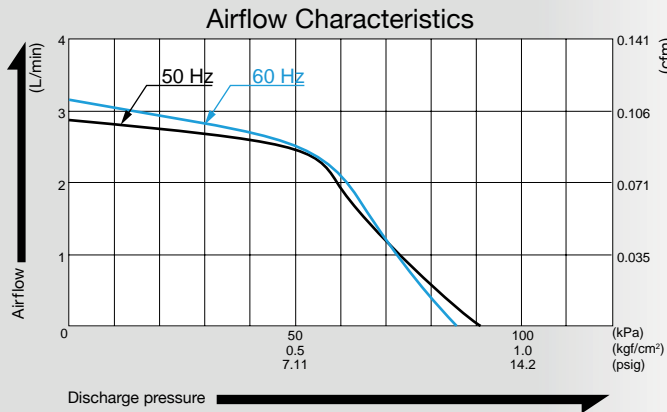

### Specifications

Rated Pressure	50 kPa (0.5 kgf/cm <sup>2</sup> ) 0.5 bar 7.11 psig	
Rated Airflow	2.5 L/min 0.088 cfm	
Maximum Pressure	80 kPa (0.8 kgf/cm <sup>2</sup> ) 0.8 bar 11.4 psig	
Rated Voltage	115 V AC	230 V AC
Power Consumption	14 W	15 W
Rated Frequency	60 Hz	50 Hz
Rated Performance (MTTF)	5,000 hours	
Outlet	6 mm O.D. hose barb	
Duty Cycle	60 minutes	
Coil Insulation Class	E or its equivalent and B for UL	
Mounting Dimensions	48 (L) x 62 (W) mm 1 - 5/8" (L) x 2 - 7/16" (W)	
Weight	0.7 kg 1.54 Lbs	
Leadwire Length	200 mm 7 - 7/8"	

### Application Examples

Saline Water Splasher

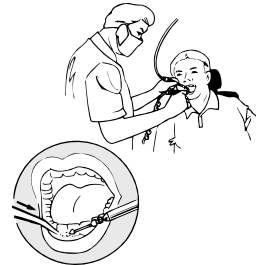

Copy Paper Separator

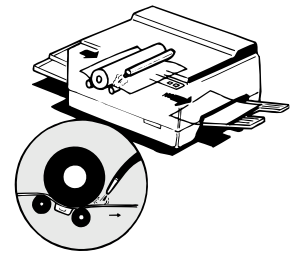

### External Dimensions (Unit: mm)

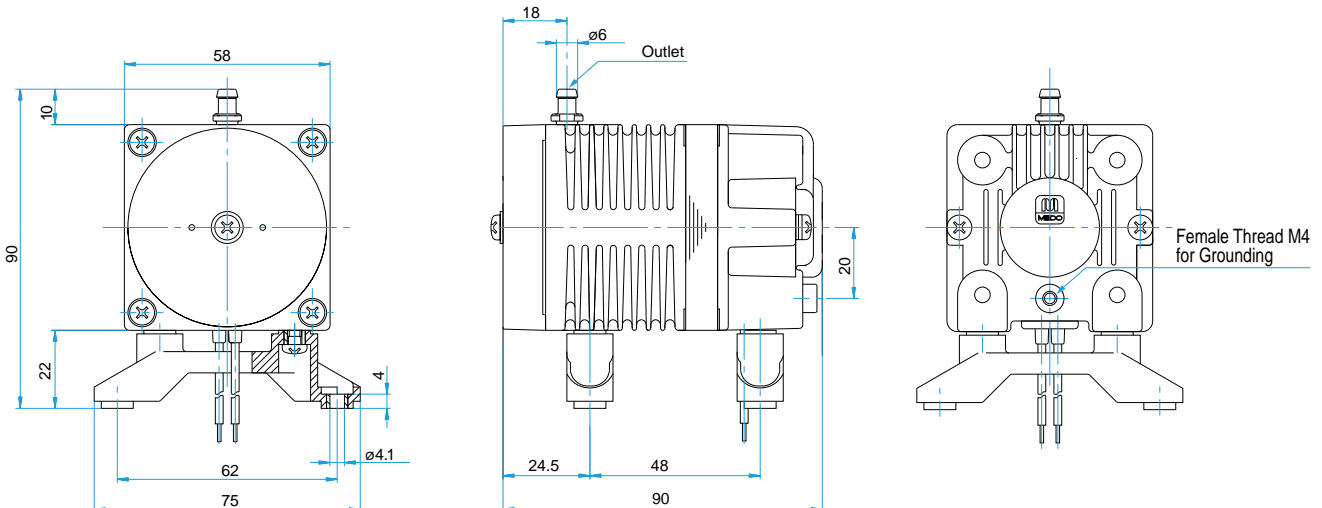

# Compressor

## Model AC0110

115 V is made to order

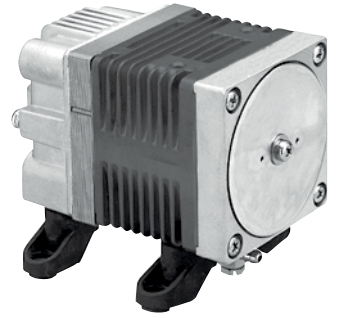

### Airflow & Power Consumption

Airflow Characteristics

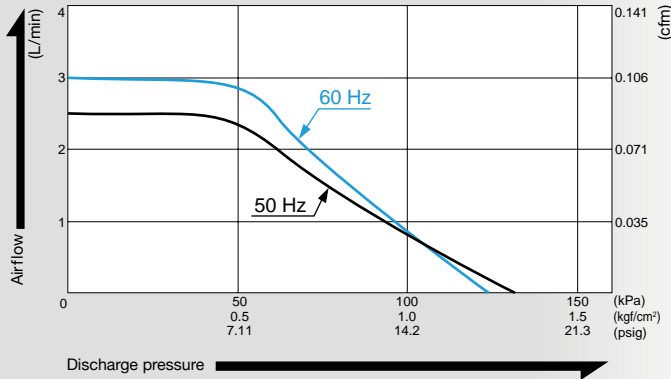

Power Consumption Characteristics

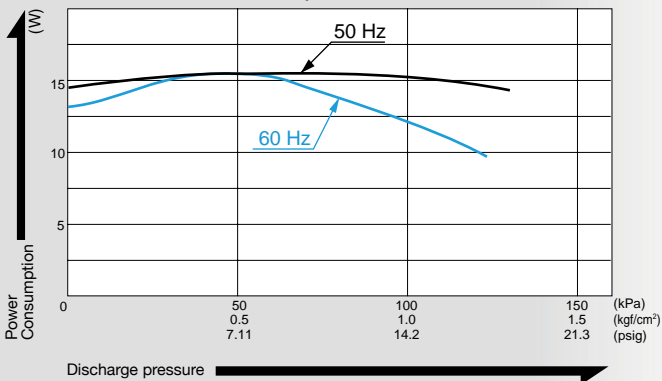

### Specifications

Rated Pressure	100 kPa (1.0 kgf/cm <sup>2</sup> ) 1.0 bar 14.2 psig	
Rated Airflow	0.8 L/min 0.028 cfm	
Maximum Pressure	120 kPa (1.2 kgf/cm <sup>2</sup> ) 1.2 bar 17.1 psig	
Rated Voltage	115 V AC	230 V AC
Power Consumption	12 W	15 W
Rated Frequency	60 Hz	50 Hz
Rated Performance (MTTF)	4,000 hours	
Outlet	6 mm O.D. hose barb	
Duty Cycle	30 minutes	
Coil Insulation Class	E or its equivalent and B for UL	
Mounting Dimensions	48 (L) x 62 (W) mm 1 - 57/64" (L) x 2 - 7/16" (W)	
Weight	0.7 kg 1.54 Lbs	
Leadwire Length	200 mm 7 - 7/8"	

### Application Examples

#### Automatic Dispenser

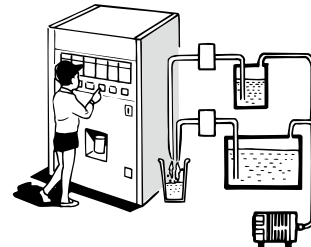

### External Dimensions (Unit: mm)

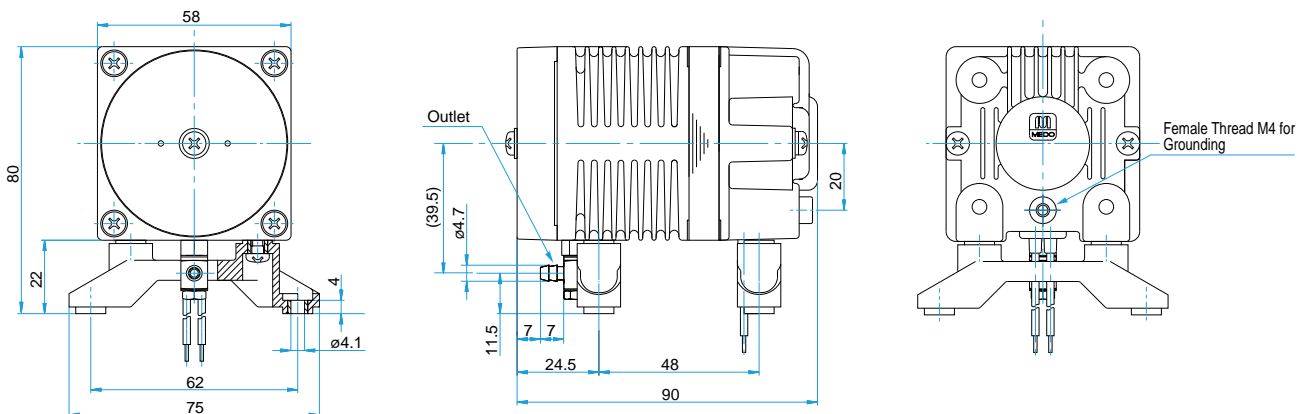

# Compressor

## Model **ACO207**

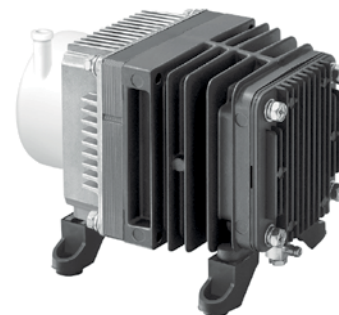

115 V

230 V

### Airflow & Power Consumption

Airflow Characteristics

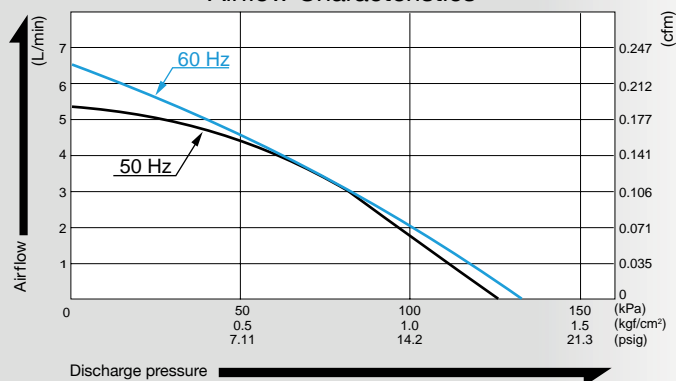

Power Consumption Characteristics

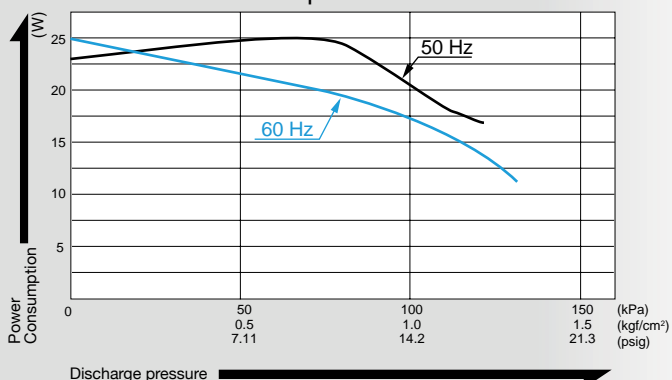

### Specifications

Rated Pressure	70 kPa (0.7 kgf/cm <sup>2</sup> ) 0.7 bar 9.96 psig	
Rated Airflow	3.5 L/min 0.124 cfm	
Maximum Pressure	100 kPa (1.0 kgf/cm <sup>2</sup> ) 1.0 bar 14.2 psig	
Rated Voltage	115 V AC	230 V AC
Power Consumption	20 W	25 W
Rated Frequency	60 Hz	50 Hz
Rated Performance	3,000 hours	
Outlet	4.7 mm O.D. hose barb	
Duty Cycle	Continuous	
Coil Insulation Class	E or its equivalent and B for UL	
Mounting Dimensions	75 (L) x 88 (W) mm 2 - 61/64" (L) x 3 - 15/32" (W)	
Weight	1.7 kg 3.7 Lbs	
Leadwire Length	200 mm 7 - 7/8"	

### Application Examples

#### Air Bearing for Precision Machines

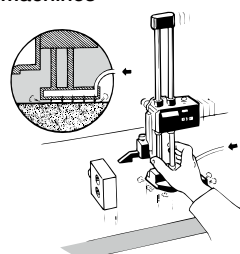

#### Nebulizer

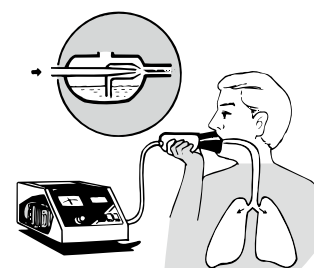

### External Dimensions (Unit: mm)

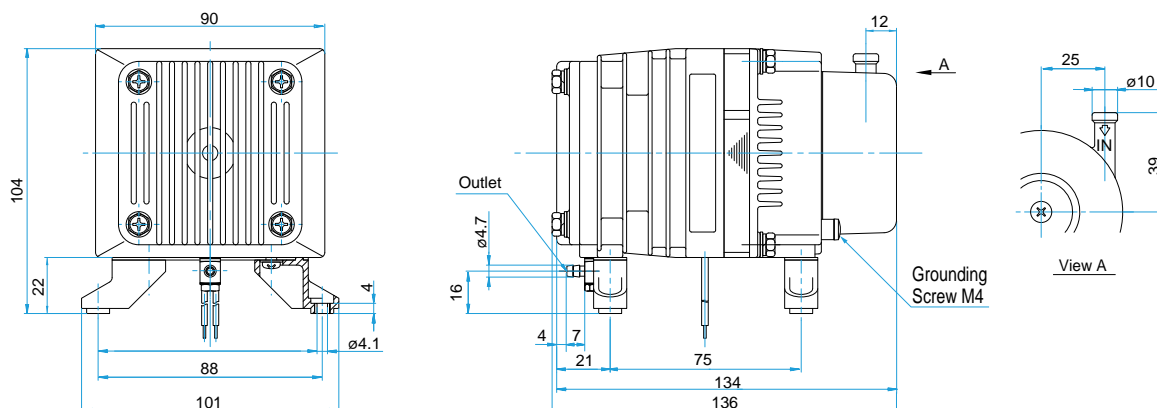

# Compressor

## Model **AC0410A**

115 V is made to order



### Airflow & Power Consumption

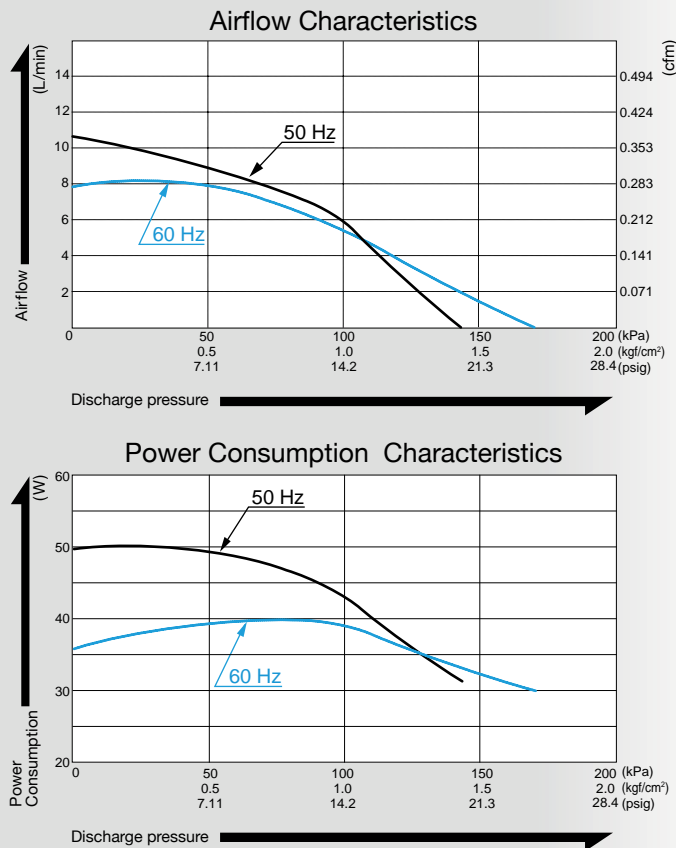

### Specifications

Rated Pressure	100 kPa (1.0 kgf/cm <sup>2</sup> ) 1.0 bar 14.2 psig	
Rated Airflow	5 L/min 0.177 cfm	
Maximum Pressure	130 kPa (1.3 kgf/cm <sup>2</sup> ) 1.3 bar 18.5 psig	
Rated Voltage	115 V AC *	230 V AC
Power Consumption	39 W	43 W
Rated Frequency	60 Hz	50 Hz
Rated Performance	3,000 hours	
Outlet	ISO Rc 1/4	
Duty Cycle	Continuous	
Coil Insulation Class	B or its equivalent	
Mounting Dimensions	68 (L) x 98 (W) mm 2 - 43/64" (L) x 3 - 55/64" (W)	
Weight	2.1 kg 4.6 Lbs	
Leadwire Length	220 mm 8 - 21/32"	170 mm 6 - 11/16"

\*115 V is made to order.

### Application Examples

#### Industrial Sewing Machine

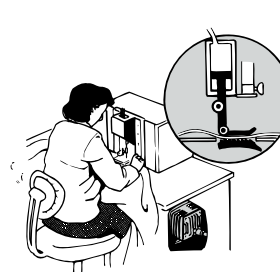

#### Various Aerosol Sprays

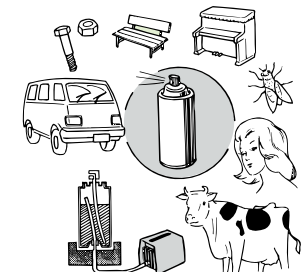

### External Dimensions (Unit: mm)

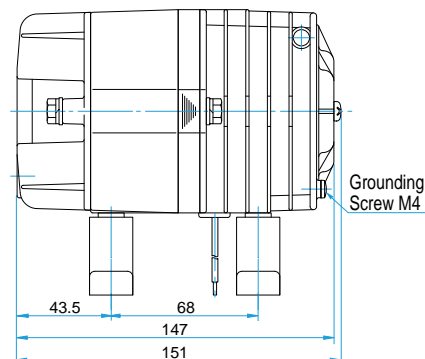
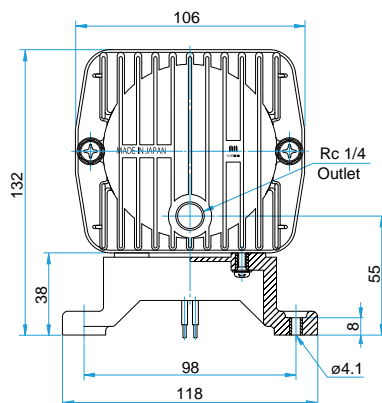

# Compressor

## Model AC0610

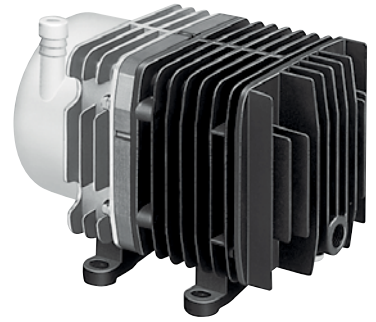

### Airflow & Power Consumption

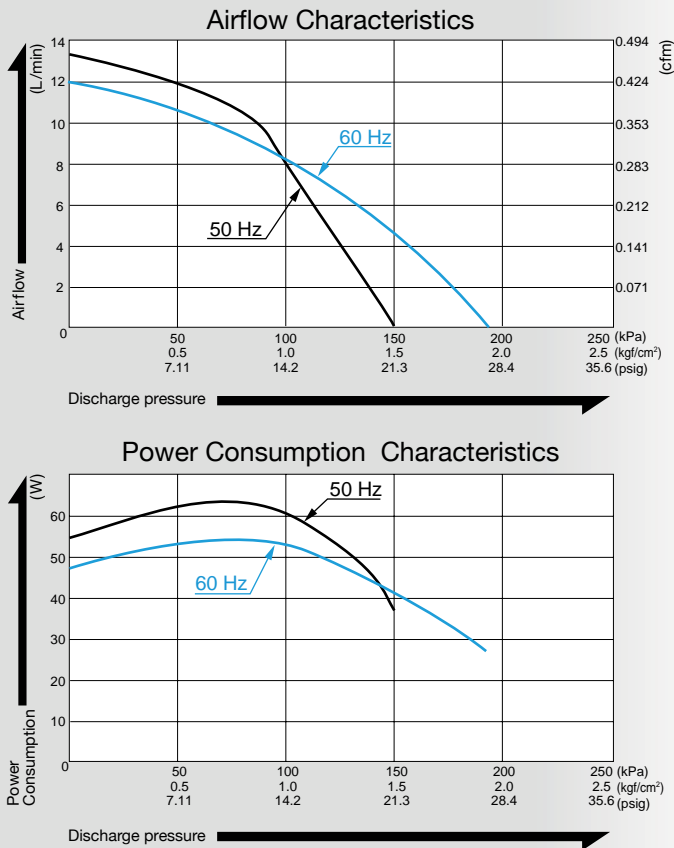

### Specifications

Rated Pressure	100 kPa (1.0 kgf/cm <sup>2</sup> ) 1.0 bar 14.2 psig	
Rated Airflow	8 L/min 0.283 cfm	
Maximum Pressure	150 kPa (1.5 kgf/cm <sup>2</sup> ) 1.5 bar 21.3 psig	
Rated Voltage	115 V AC	230 V AC
Power Consumption	52 W	60 W
Rated Frequency	60 Hz	50 Hz
Rated Performance	3,000 hours	
Outlet	ISO Rc 1/4	
Duty Cycle	Continuous	
Coil Insulation Class	E or its equivalent and B for UL	
Mounting Dimensions	68 (L) x 84 (W) mm 2 - 43/64" (L) x 3 - 5/16" (W)	
Weight	3.2 kg 7.1 Lbs	
Leadwire Length	200 mm 7 - 7/8"	

### Application Examples

#### Dispenser

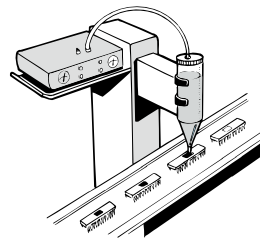

#### Automatic Stamper

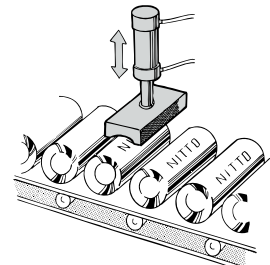

### External Dimensions (Unit: mm)

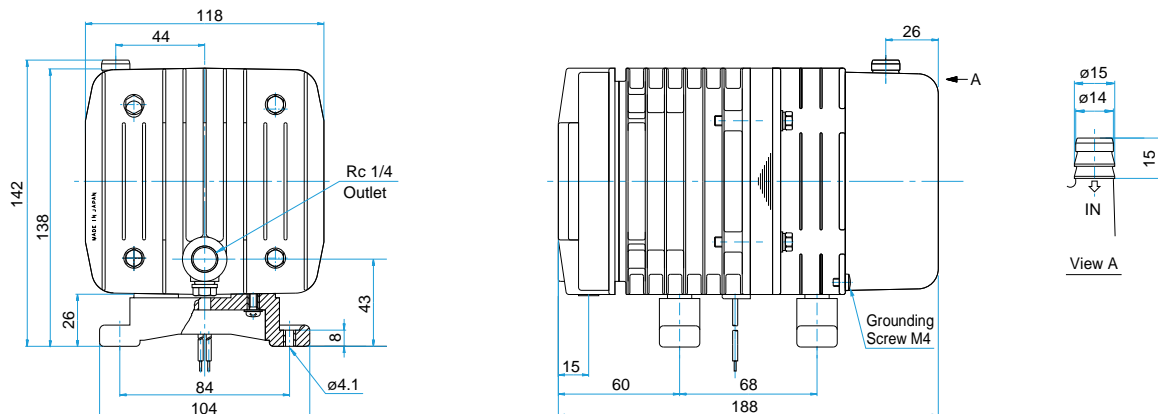

# Compressor

## Model AC0910

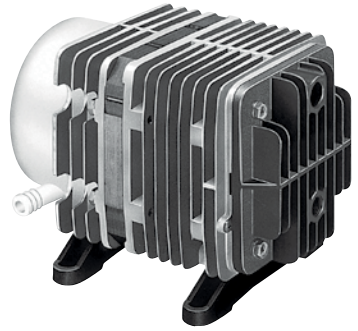

### Airflow & Power Consumption

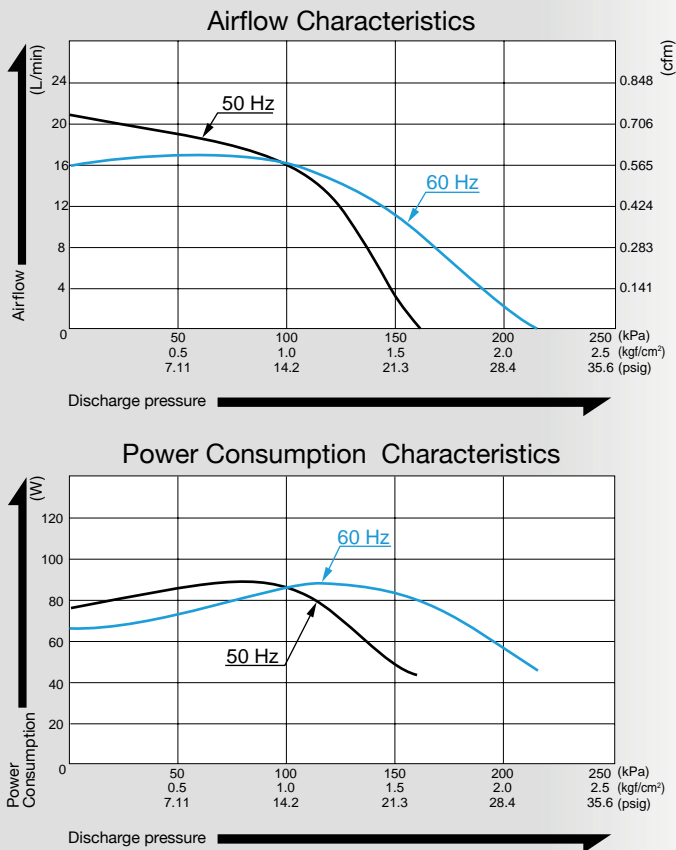

### Specifications

Rated Pressure	100 kPa (1.0 kgf/cm <sup>2</sup> ) 1.0 bar 14.2 psig	
Rated Airflow	16 L/min 0.57 cfm	
Maximum Pressure	150 kPa (1.5 kgf/cm <sup>2</sup> ) 1.5 bar 21.3 psig	
Rated Voltage	115 V AC	230 V AC
Power Consumption	85 W	90 W
Rated Frequency	60 Hz	50 Hz
Rated Performance	3,000 hours	
Outlet	ISO Rc 1/4	
Duty Cycle	Continuous	
Coil Insulation Class	E or its equivalent or B for UL	
Mounting Dimensions	102 (L) x 130 (W) mm 4 - 1/64" (L) x 5 - 1/8" (W)	
Weight	4.9 kg 10.8 Lbs	
Leadwire Length	300 mm 11 - 13/16"	320 mm 12 - 19/32"

### Application Examples

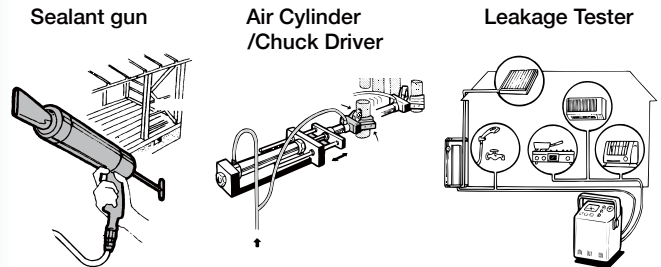

### External Dimensions (Unit: mm)

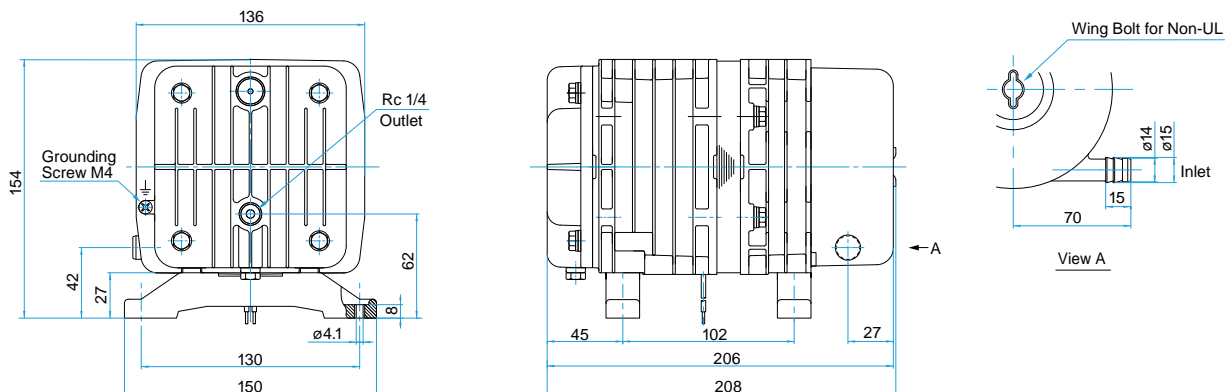



# Compressor

## Model AC0920

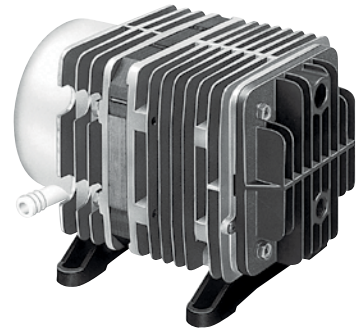

### Airflow & Power Consumption

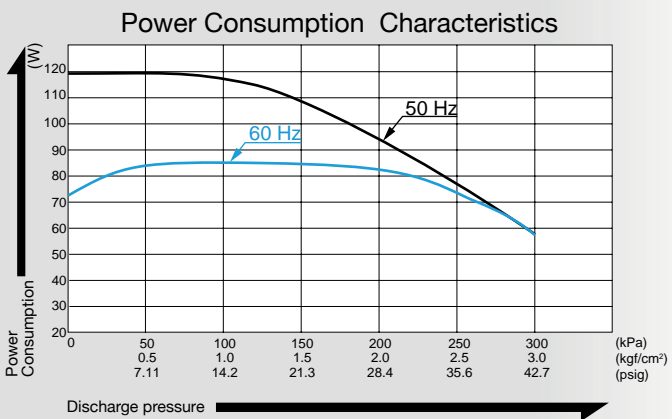
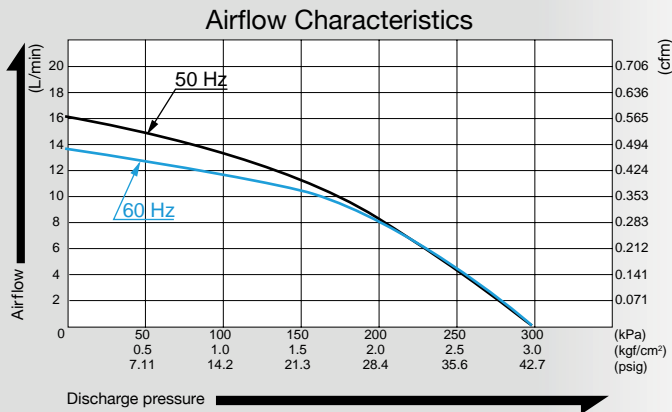

### Specifications

Rated Pressure	200 kPa (2.0 kgf/cm <sup>2</sup> ) 2.0 bar 28.4 psig	
Rated Airflow	8 L/min 0.283 cfm	
Maximum Pressure	300 kPa (3.0 kgf/cm <sup>2</sup> ) 3.0 bar 42.7 psig	
Rated Voltage	115 V AC	230 V AC
Power Consumption	81 W	100 W
Rated Frequency	60 Hz	50 Hz
Rated Performance	3,000 hours	
Outlet	ISO Rc 1/4	
Duty Cycle	30 minutes	
Coil Insulation Class	E or its equivalent	
Mounting Dimensions	102 (L) x 130 (W) mm 4 - 1/64" (L) x 5 - 1/8" (W)	
Weight	5 kg 11 Lbs	
Leadwire Length	300 mm 11 - 13/16"	150 mm 5 - 29/32"

### Application Examples

Air Cylinder/Chuck Driver

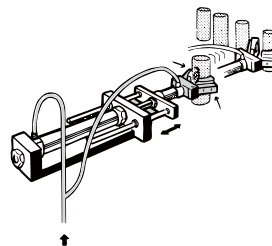

Leakage Tester

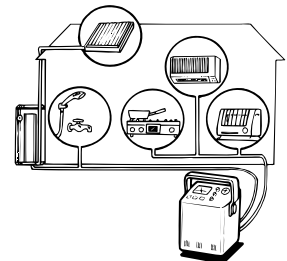

### External Dimensions (Unit: mm)

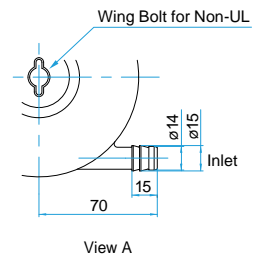
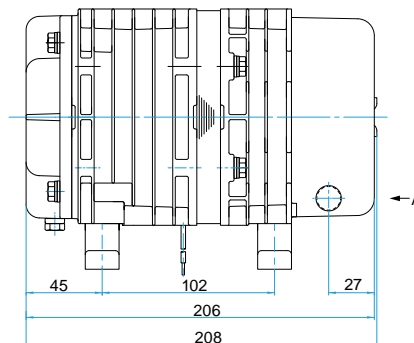
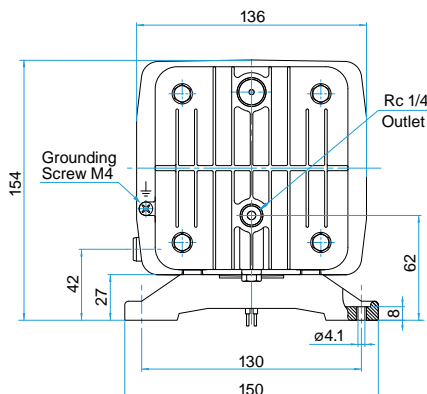



# VACUUM PUMP

VP0125	—	27
VP0140	—	28
VP0435A	—	29
VP0450	—	30
VP0625	—	31
VP0660	—	32
VP0940	—	33
VP0940T	—	34

**VP series**

**Made to Order**

VP0645	—	103
VP0945	—	104
VP0925A	—	105
VP0660 x 2	—	106

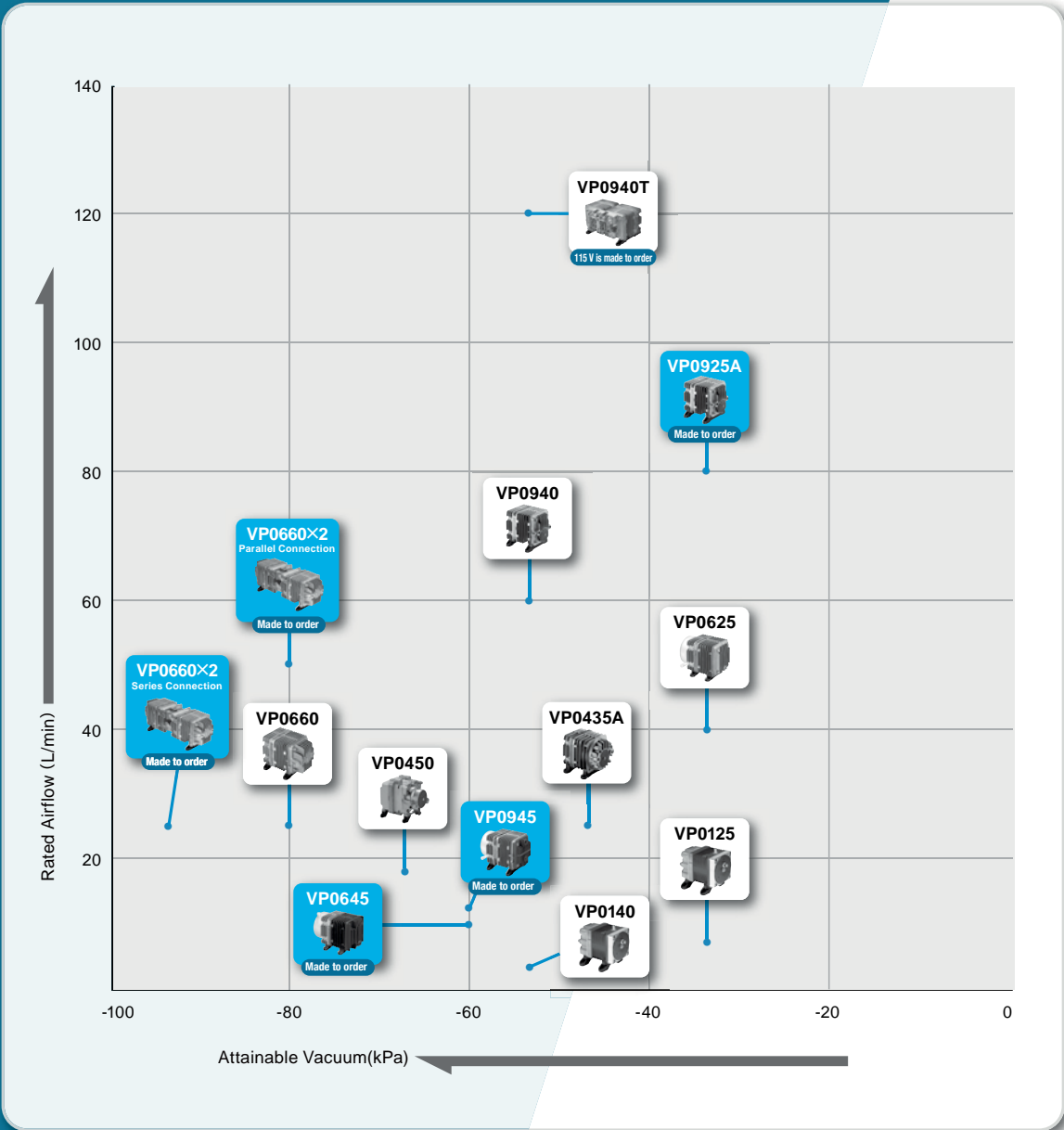

# Vacuum Pump

## Model VP0125

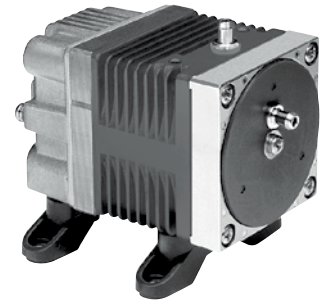

### Airflow & Power Consumption

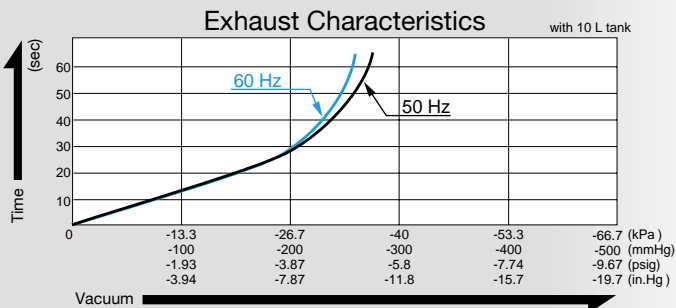
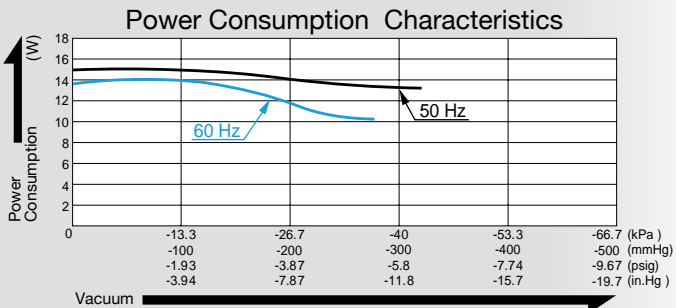
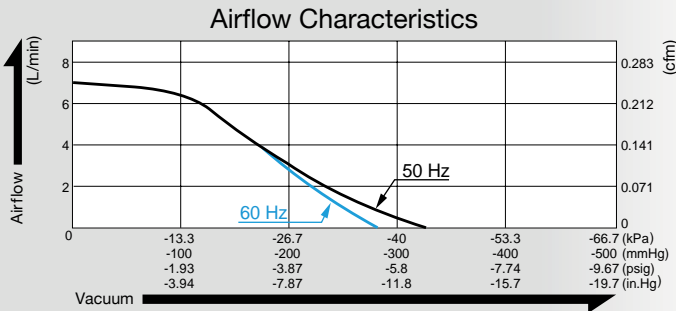

### Specifications

Attainable Vacuum	-33.3 kPa (-250 mmHg) -333 mbar -9.84 in. Hg	
Free Air Displacement	7 L/min 0.247 cfm	
Rated Voltage	115 V AC	230 V AC
Power Consumption	14 W	15 W
Rated Frequency	60 Hz	50 Hz
Rated Performance (MTTF)	10,000 hours	
Inlet	6 mm O.D. hose barb	
Outlet	6 mm O.D. hose barb	
Duty Cycle	Continuous	
Coil Insulation Class	Class B for UL	
Mounting Dimensions	48 (L) x 62 (W) mm 1 - 57/64" (L) x 2 - 7/16" (W)	
Weight	0.7 kg	1.54 Lbs
Leadwire Length	200 mm	7 - 7/8"

### Application Examples

Dripping Machine

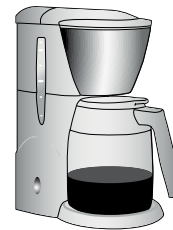

Paper Card Dispenser

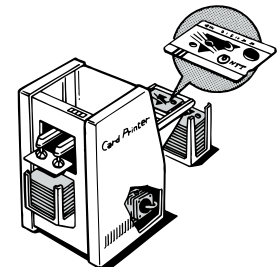

### External Dimensions (Unit: mm)

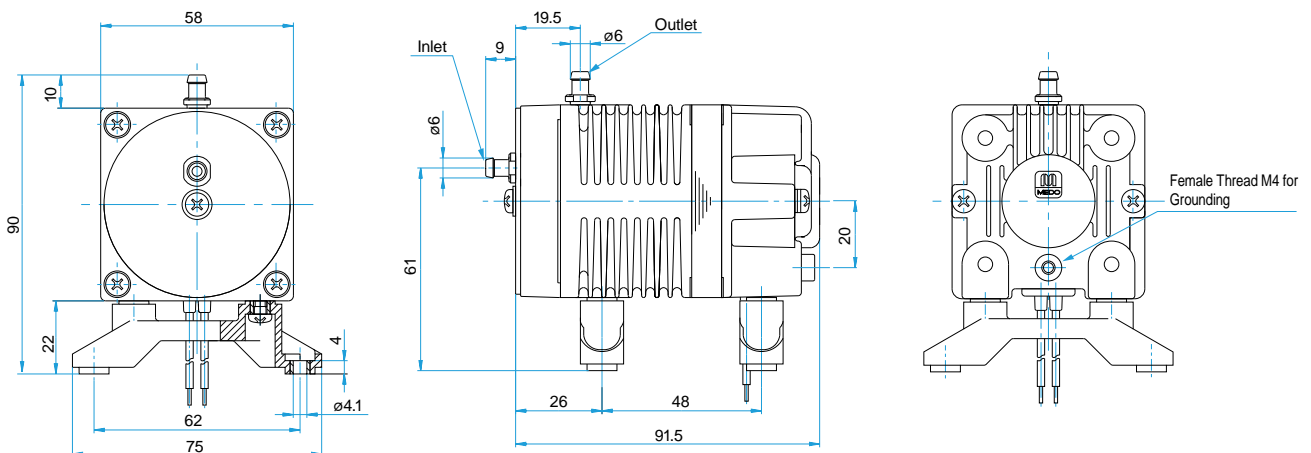

# Vacuum Pump

## Model VP0140

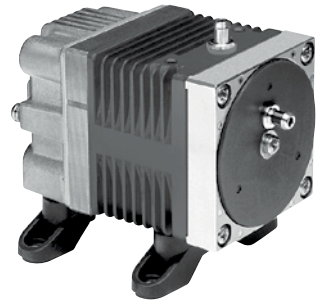

### Airflow & Power Consumption

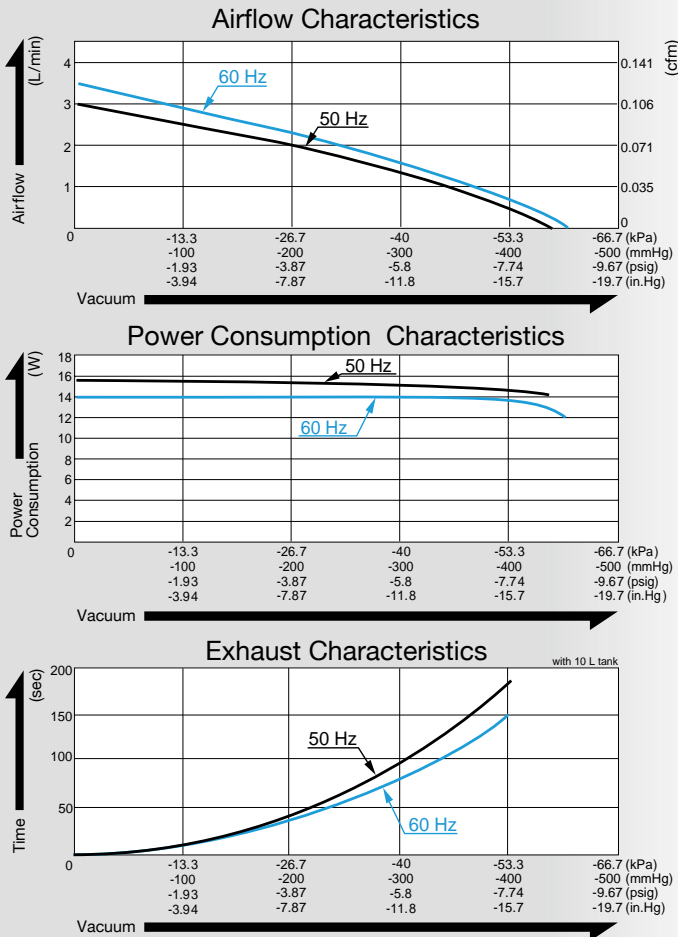

### Specifications

Attainable Vacuum*	-53.3 kPa (-400 mmHg) -533 mbar -15.7 in. Hg	
Free Air Displacement	3 L/min 0.106 cfm	
Rated Voltage	115 V AC	230 V AC
Power Consumption	14 W	15 W
Rated Frequency	60 Hz	50 Hz
Rated Performance (MTTF)	5,000 hours	
Inlet	6 mm O.D. hose barb	
Outlet	6 mm O.D. hose barb	
Duty Cycle	60 minutes	
Coil Insulation Class	E or its equivalent and B for UL	
Mounting Dimensions	48 (L) x 62 (W) mm 1 - 57/64" (L) x 2 - 7/16" (W)	
Weight	0.7 kg 1.54 Lbs	
Leadwire Length	200 mm 7 - 7/8"	

\*Operations at higher than -53.5 kPa need an additional leak valve or relief valve on the inlet piping.

### Application Examples

Dripping Machine

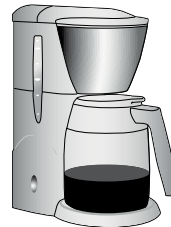

Paper Card Dispenser

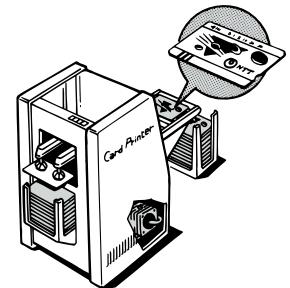

### External Dimensions (Unit: mm)

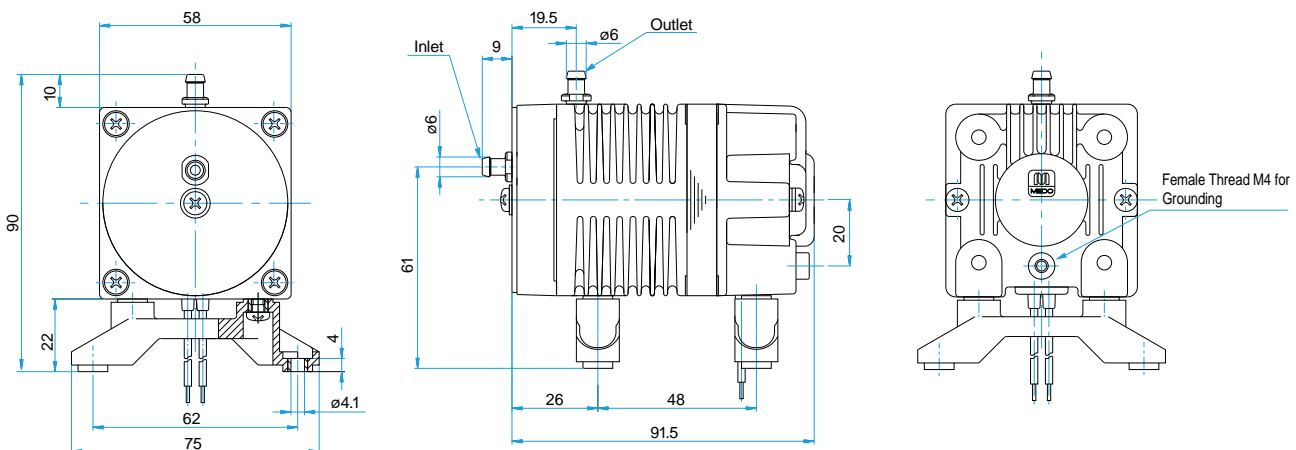

# Vacuum Pump

## Model VPO435A

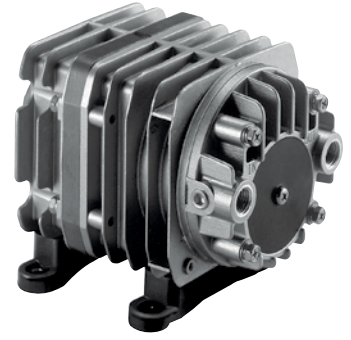

### Airflow & Power Consumption

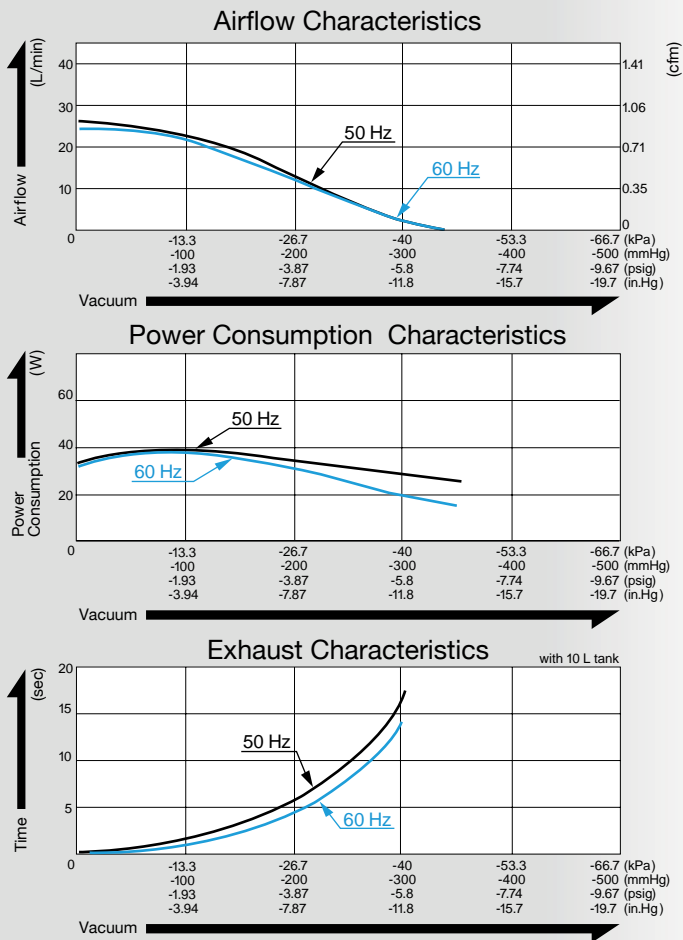

### Specifications

Attainable Vacuum	-46.7 kPa (-350 mmHg) -467 mbar -13.8 in. Hg	
Free Air Displacement	25 L/min 0.88 cfm	
Rated Voltage	115 V AC	230 V AC
Power Consumption	39 W	
Rated Frequency	60 Hz	50 Hz
Rated Performance	3,000 hours	
Inlet	15 mm O.D. hose barb	
Outlet	ISO Rc 1/4	
Duty Cycle	Continuous	
Coil Insulation Class	B or its equivalent and B for UL	
Mounting Dimensions	68 (L) x 84 (W) mm 2 - 43/64" (L) x 3 - 5/16" (W)	
Weight	2.3 kg 5.1 Lbs	
Leadwire Length	300 mm 11 - 13/16"	550 mm 21 - 21/32"

### Application Examples

Machine Screw Feeder



Air Sampler

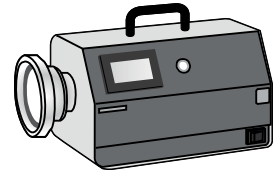

### External Dimensions (Unit: mm)

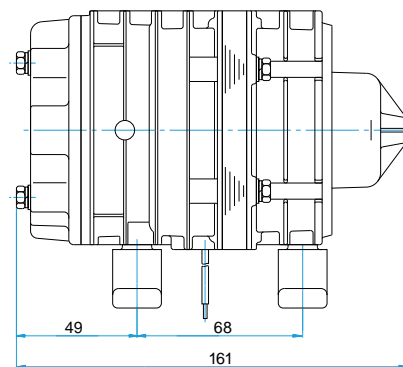
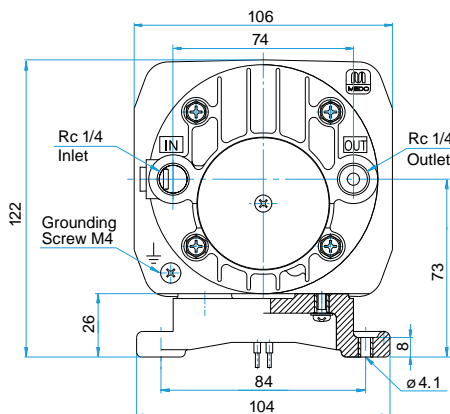

# Vacuum Pump

## Model VPO450

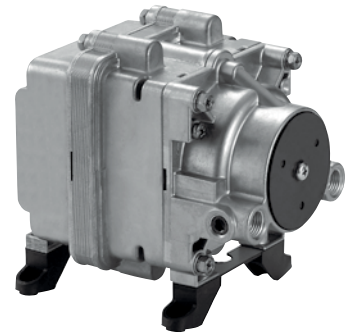

### Airflow & Power Consumption

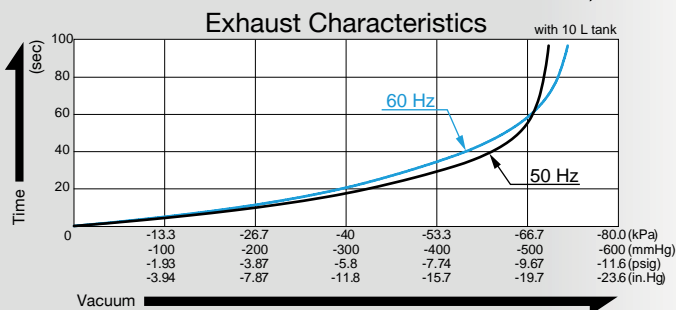
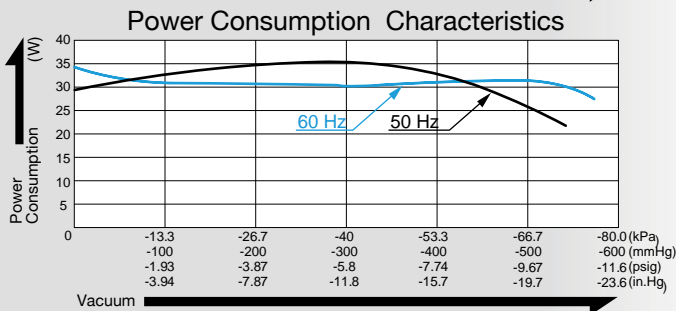
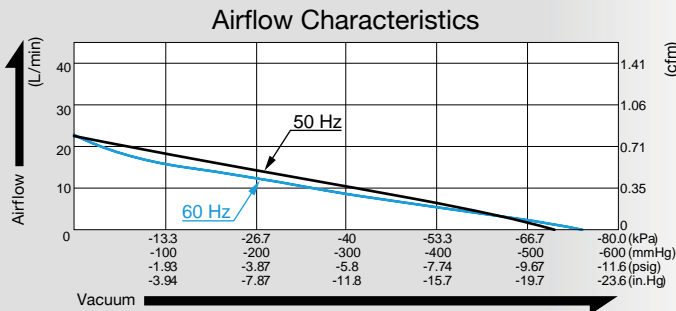

### Specifications

Attainable Vacuum	-66.7 kPa (-500 mmHg) -667 mbar -19.7 in. Hg	
Free Air Displacement	18 L/min 0.64 cfm	
Rated Voltage	120 V AC	230 V AC
Power Consumption	34 W	35 W
Rated Frequency	60 Hz	50 Hz
Rated Performance	10,000 hours	
Inlet	ISO Rc 1/4	
Outlet	ISO Rc 1/4	
Duty Cycle	Continuous	
Coil Insulation Class	E or its equivalent and A for UL	
Mounting Dimensions	85 (L) x 88 (W) mm 3 - 11/32" (L) x 3 - 15/32" (W)	
Weight	2.2 kg 4.9 Lbs	
Leadwire Length	300 mm 11 - 13/16"	

### Application Examples

#### Machine Screw Feeder



#### Air Sampler

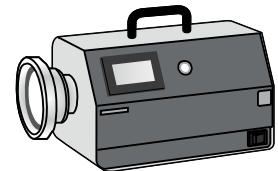

### External Dimensions (Unit: mm)

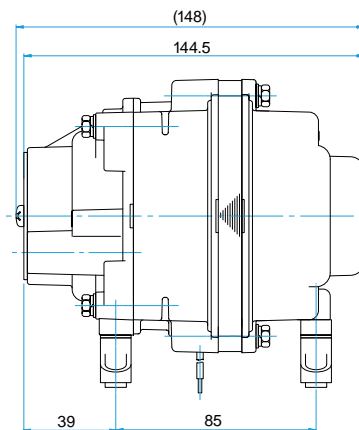
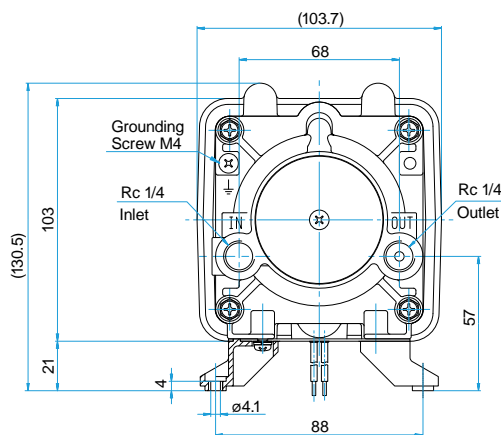

# Vacuum Pump

## Model VP0625

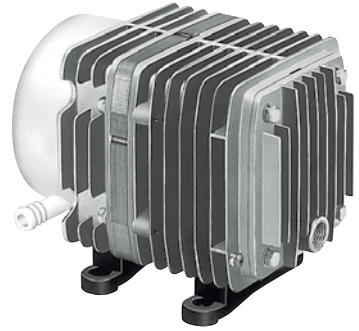

### Airflow & Power Consumption

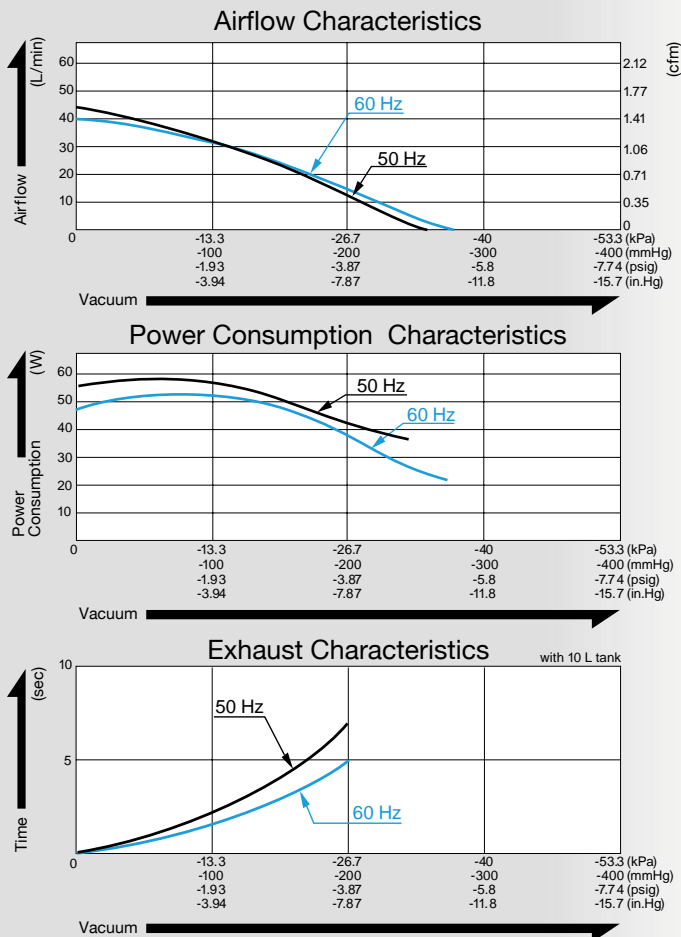

### Specifications

Attainable Vacuum	-33.3 kPa (-250 mmHg) -333 mbar -9.84 in. Hg	
Free Air Displacement	40 L/min 1.41 cfm	
Rated Voltage	115 V AC	230 V AC
Power Consumption	60 W	
Rated Frequency	60 Hz	50 Hz
Rated Performance	10,000 hours	
Inlet	15mm O.D. hose barb	
Outlet	ISO Rc 1/4	
Duty Cycle	Continuous	
Coil Insulation Class	E or its equivalent and B for UL	
Mounting Dimensions	68 (L) x 84 (W) mm 2 - 43/64" (L) x 3 - 5/16" (W)	
Weight	3 kg 6.6 Lbs	
Leadwire Length	235 mm 9 - 1/4"	320 mm 12 - 19/32"

### Application Examples

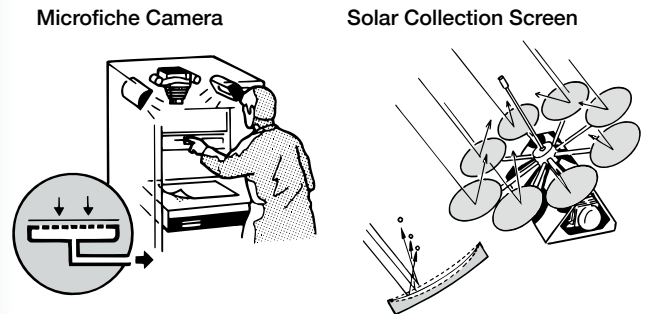

### External Dimensions (Unit: mm)

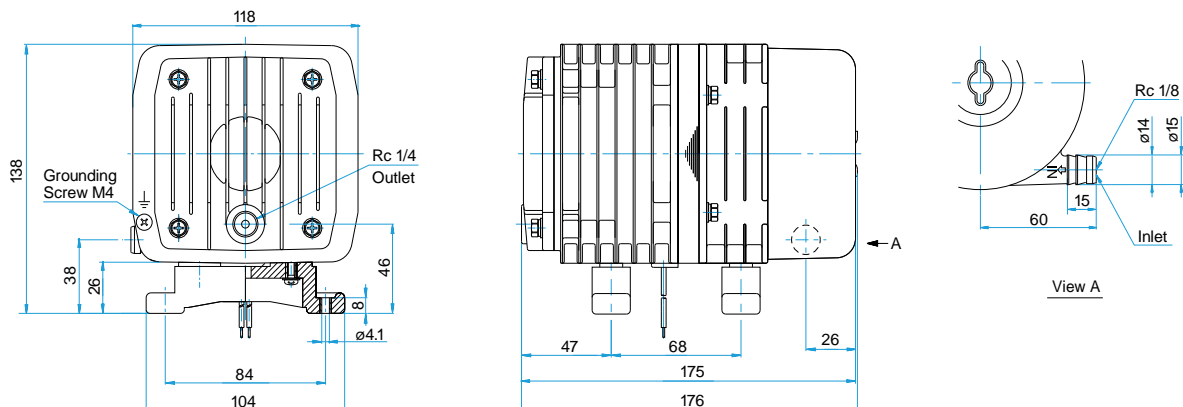



# Vacuum Pump

## Model VPO660



### Airflow & Power Consumption

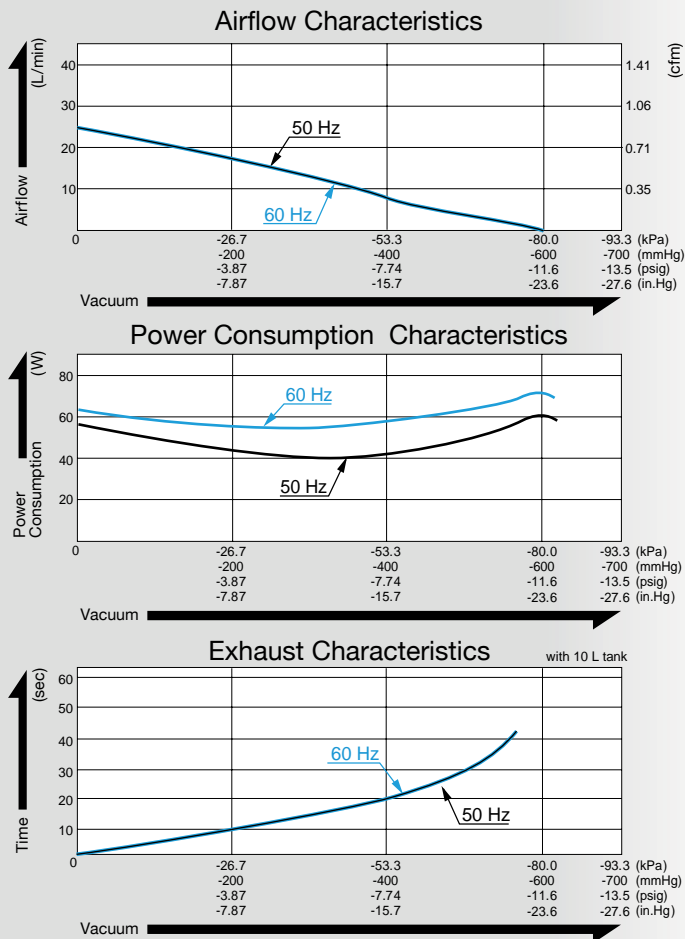

### Specifications

Attainable Vacuum *1	-80 kPa (-600 mmHg) -800 mbar -23.6 in. Hg	
Free Air Displacement	25 L/min 0.88 cfm	
Rated Voltage	115 V AC	230 V AC
Power Consumption	70 W	60 W
Rated Frequency	60 Hz	50 Hz
Rated Performance	6,000 hours	
Inlet	ISO Rc 1/4	
Outlet	ISO Rc 1/4	
Duty Cycle	Continuous	
Coil Insulation Class	E or its equivalent and B for UL	
Mounting Dimensions	102 (L) x 130 (W) mm 4 - 1/64" (L) x 5 - 1/8" (W)	
Weight	5 kg 11 Lbs	
Leadwire Length	300 mm 11 - 13/16"	600 mm 23 - 5/8"

\*1: Operations at higher than -80 kPa need an additional leak valve or relief valve on the inlet piping.

### Application Examples

#### Vacuum Material Handling Equipment

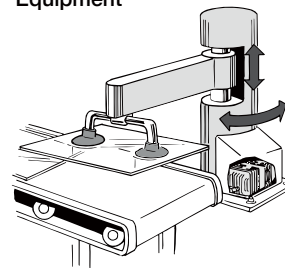

#### Vacuum Chucking



### External Dimensions (Unit: mm)

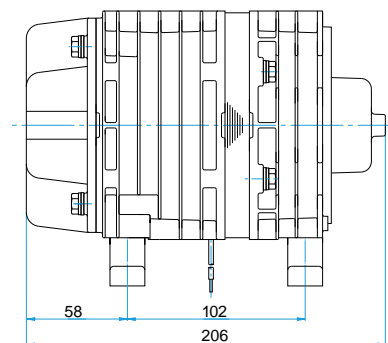
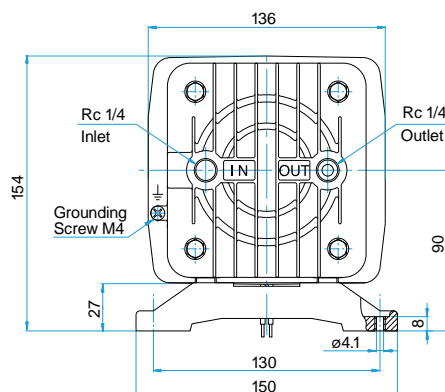

# Vacuum Pump

## Model VP0940

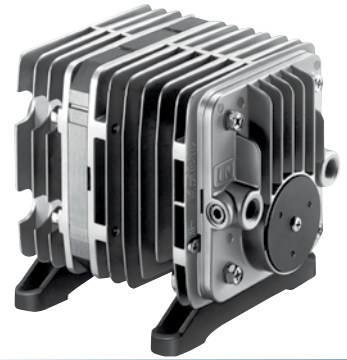

### Airflow & Power Consumption

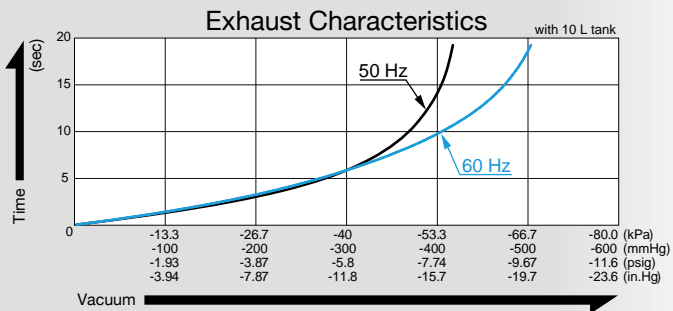
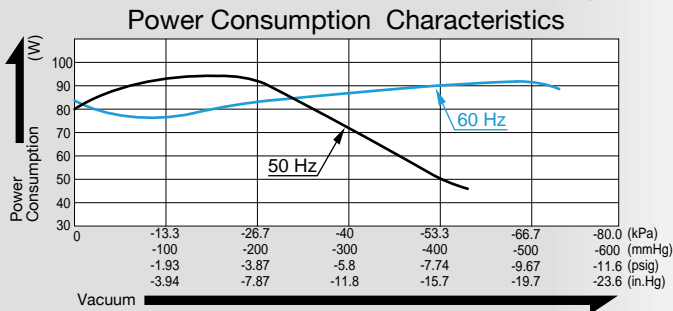
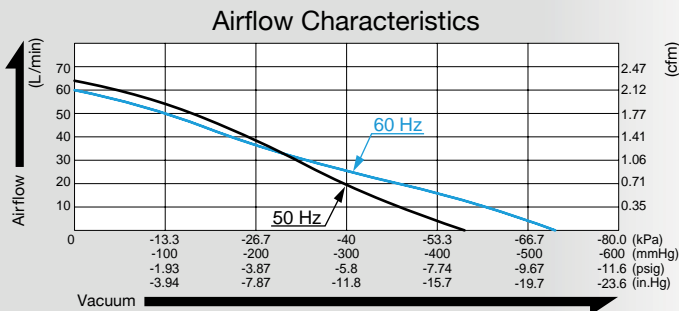

### Specifications

Attainable Vacuum *1	-53.3 kPa (-400 mmHg) -533 mbar -15.7 in. Hg	
Free Air Displacement	60 L/min 2.12 cfm	
Rated Voltage	115 V AC	230 V AC
Power Consumption	95 W	
Rated Frequency	60 Hz	50 Hz
Rated Performance	10,000 hours	
Inlet	ISO Rc 1/4	
Outlet	ISO Rc 1/4	
Duty Cycle	Continuous	
Coil Insulation Class	B or its equivalent and B for UL	
Mounting Dimensions	102 (L) x 130 (W) mm 4 - 1/64" (L) x 5 - 1/8" (W)	
Weight	4.55 kg 10.0 Lbs	
Leadwire Length	300 mm 11 - 13/16"	320 mm 12 - 19/32"

\*1: Operations at higher than -53.3 kPa need an additional leak valve or relief valve on the inlet piping.

### Application Examples

#### Label Sticking Machine

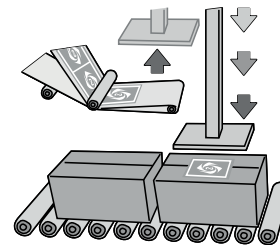

### External Dimensions (Unit: mm)

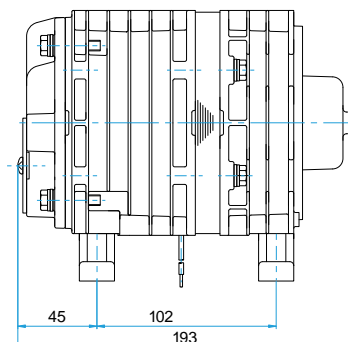
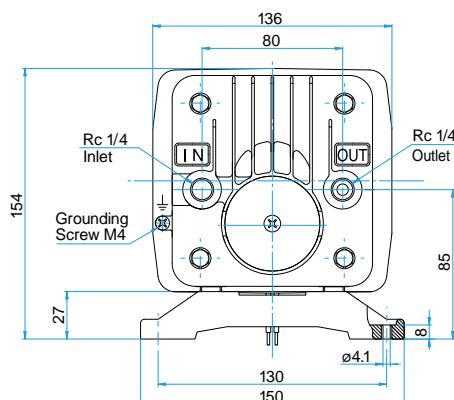

# Vacuum Pump

## Model VP0940T

115 V is made to order

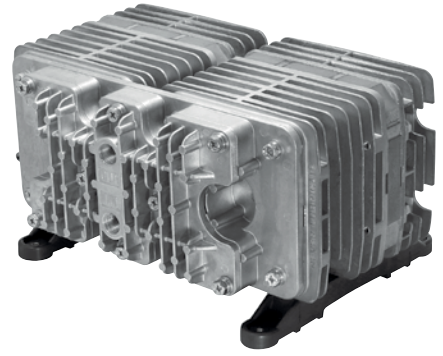

### Airflow & Power Consumption

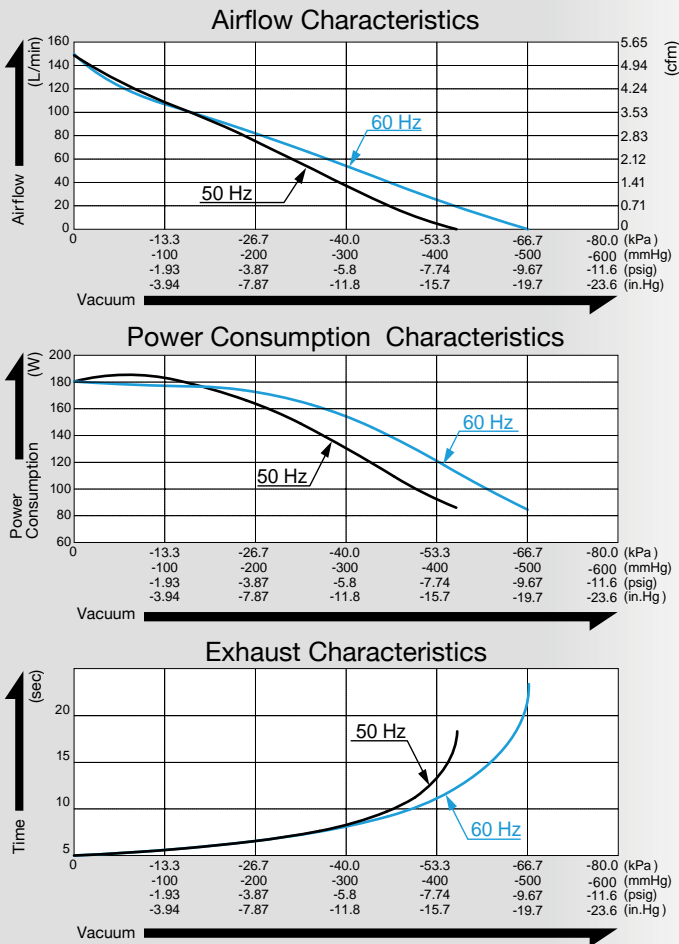

### Specifications

Attainable Vacuum *1	-53.3 kPa (-400 mmHg) -533 mbar -15.7 in. Hg	
Free Air Displacement	120 L/min 4.24 cfm	
Rated Voltage	115 V AC *2	230 V AC
Power Consumption	185 W	
Rated Frequency	60 Hz	50 Hz
Rated Performance	10,000 hours	
Inlet	ISO Rc 3/8	
Outlet	ISO Rc 3/8	
Duty Cycle	Continuous	
Coil Insulation Class	B or its equivalent	
Mounting Dimensions	172 (L) x 211 (W) mm 6 - 49/64" (L) x 8 - 5/16" (W)	
Weight	10 kg 22 Lbs	
Leadwire Length	300 mm 11 - 13/16"	320 mm 12 - 19/32"

\*1: Operations at higher than -53.3 kPa need an additional leak valve or relief valve on the inlet piping.

### Wiring diagram

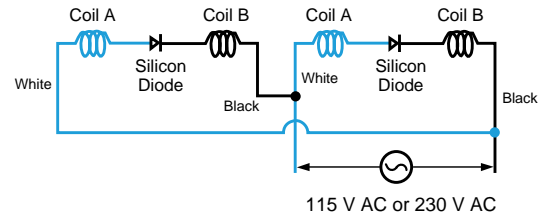

\*The silencer, air filter, and pipe are not included with the product.  
\*Piping and wiring need to be done by the user.

### External Dimensions (Unit: mm)

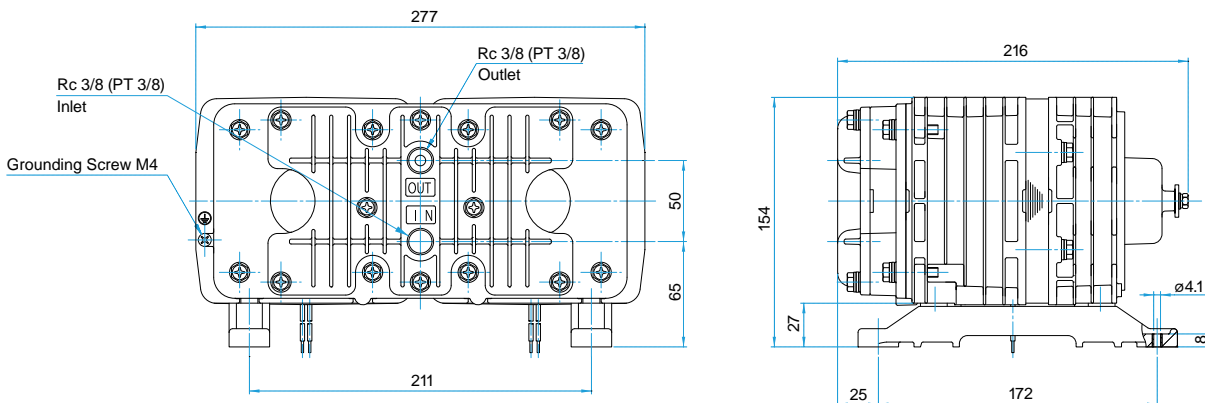



# AIR COMPRESSOR

**DAH series**

DAH102-X1	—	37
DAH102-Y1	—	38
DAH105-X1	—	39
DAH105-Y1	—	40
DAH110-X1	—	41
DAH110-Y1	—	42

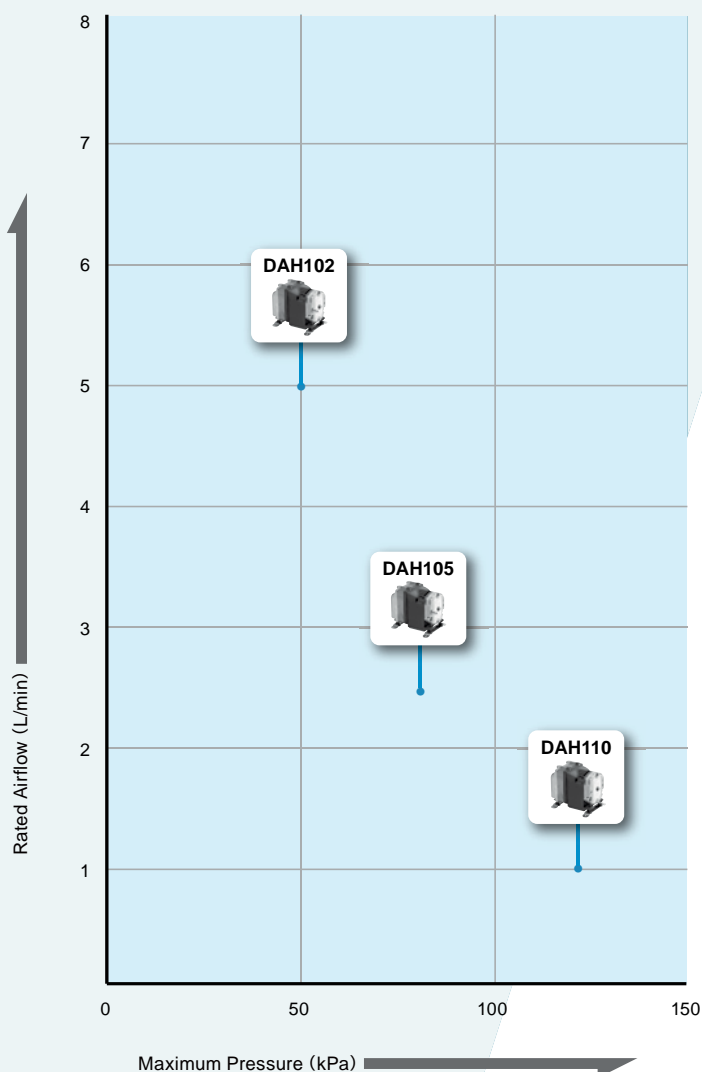

# Compressor

## Model **DAH102-X1**

12 V DC

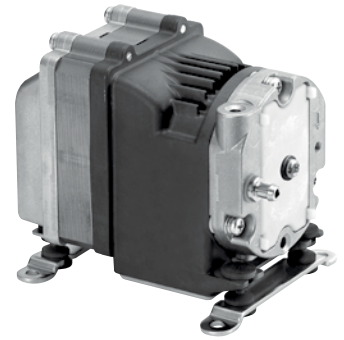

### Airflow & Electric Current

Airflow Characteristics

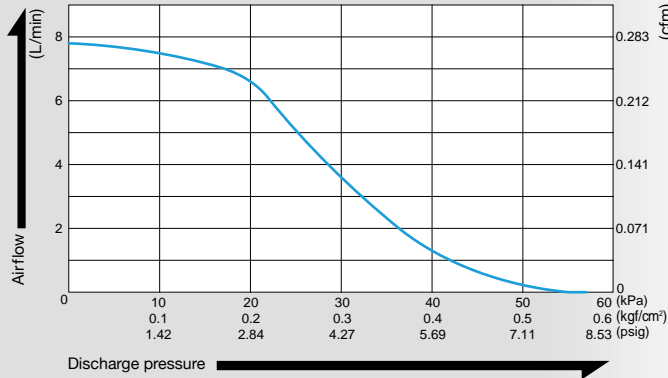

Current Characteristics

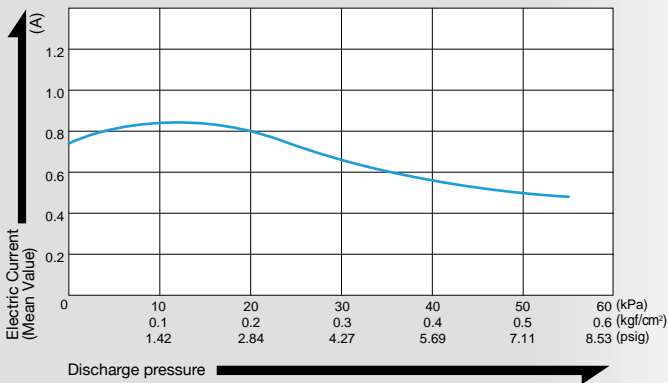

### Specifications

Rated Pressure	20 kPa (0.2 kgf/cm <sup>2</sup> ) 0.2 bar 2.84 psig
Rated Airflow	5 L/min *1 0.177 cfm
Maximum Pressure	50 kPa (0.5 kgf/cm <sup>2</sup> ) 0.5 bar 7.11 psig
Rated Voltage	12 V DC
Current (Mean Value)	0.81 A
Rated Performance (MTTF)	10,000 hours
Outlet	6 mm O.D. hose barb
Duty Cycle	Continuous
Coil Insulation Class	A or its equivalent
Mounting Dimensions	76 (L) x 70 (W) mm 2 - 63/64" (L) x 2 - 3/4" (W)
Weight	0.91 kg 2.01 Lbs
Leadwire Length	300 mm 11 - 13/16"

\*1: Airflow at rated pressure.

### Optional Accessory (LB07793)

Heavy duty rubber feet available on request.

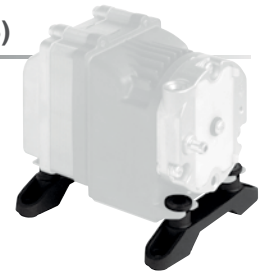

### Application Examples

Medical equipment, analyzers, etc.

### External Dimensions (Unit: mm)

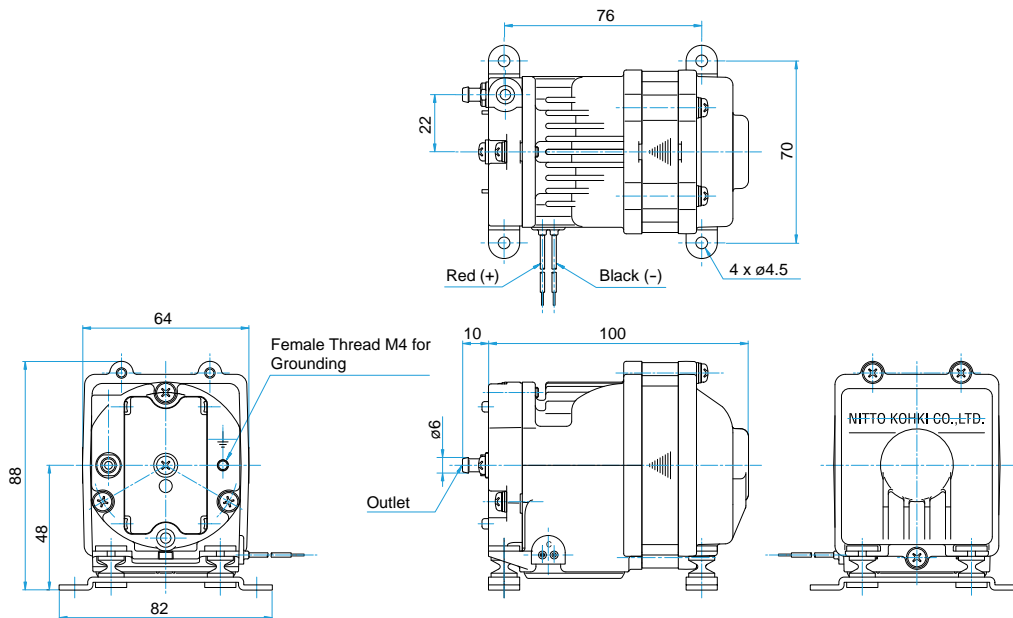

# Compressor

## Model **DAH102-Y1**

24 V DC

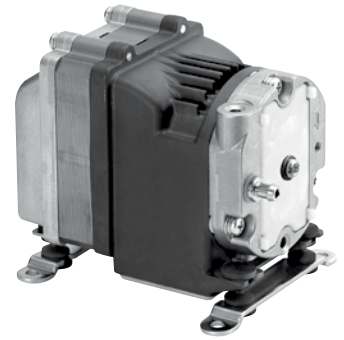

### Airflow & Electric Current

Airflow Characteristics

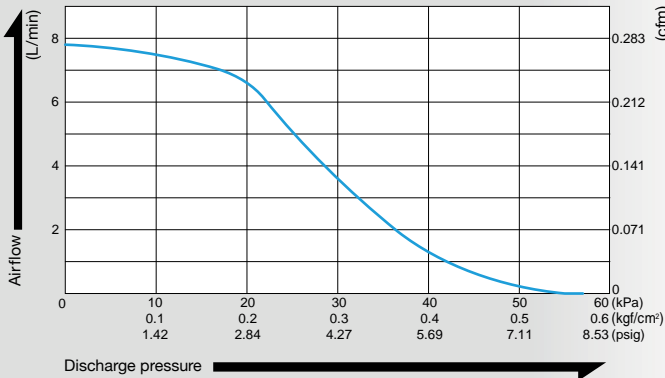

Current Characteristics

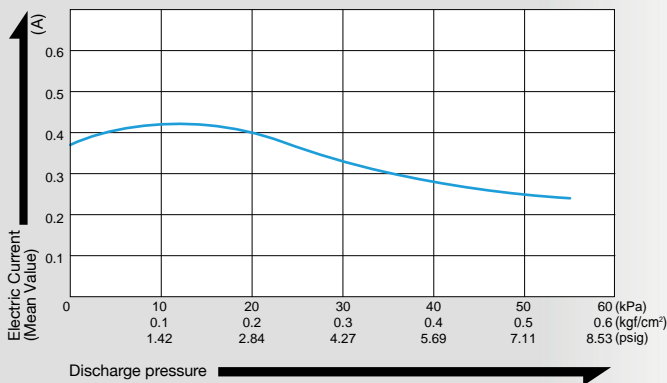

### Specifications

Rated Pressure	20 kPa (0.2 kgf/cm <sup>2</sup> ) 0.2 bar 2.84 psig
Rated Airflow	5 L/min *1 0.177 cfm
Maximum Pressure	50 kPa (0.5 kgf/cm <sup>2</sup> ) 0.5 bar 7.11 psig
Rated Voltage	24 V DC
Current (Mean Value)	0.40 A
Rated Performance (MTTF)	10,000 hours
Outlet	6 mm O.D. hose barb
Duty Cycle	Continuous
Coil Insulation Class	A or its equivalent
Mounting Dimensions	76 (L) x 70 (W) mm 2 - 63/64" (L) x 2 - 3/4" (W)
Weight	0.91 kg 2.01 Lbs
Leadwire Length	300 mm 11 - 13/16"

\*1: Airflow at rated pressure.

### Optional Accessory (LB07793)

Heavy duty rubber feet available on request.

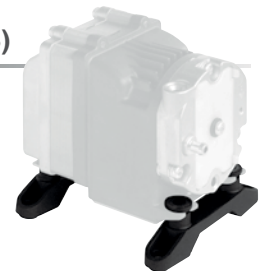

### Application Examples

Medical equipment, analyzers, etc.

### External Dimensions (Unit: mm)

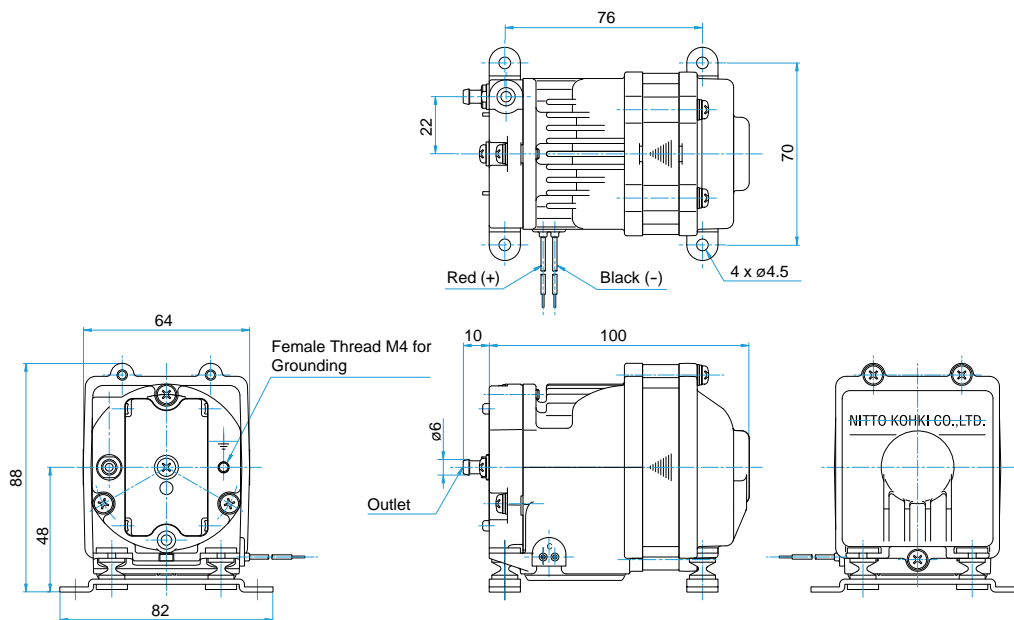

# Compressor

## Model **DAH105-X1**

12 V DC

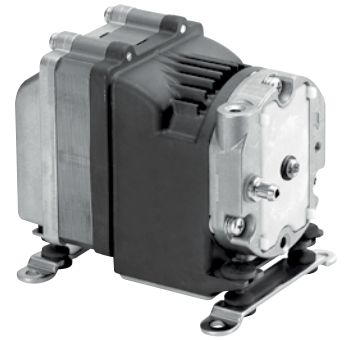

### Airflow & Electric Current

Airflow Characteristics

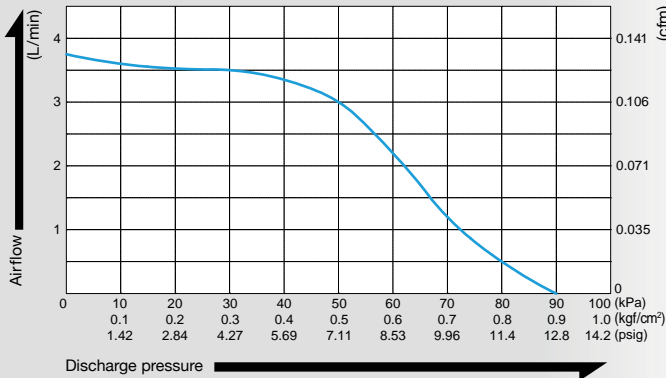

Current Characteristics

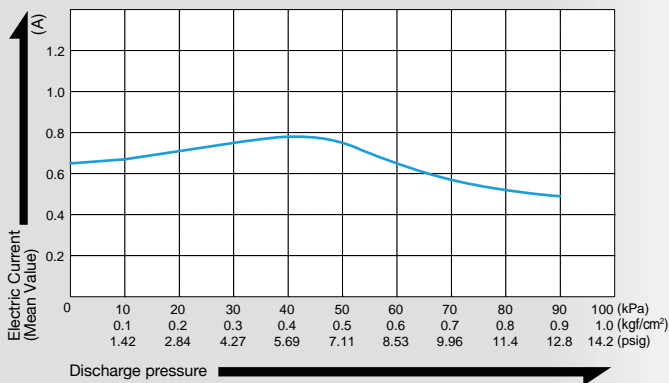

### Specifications

Rated Pressure	50 kPa (0.5 kgf/cm <sup>2</sup> ) 0.5 bar 7.11 psig
Rated Airflow	2.5 L/min *1 0.088 cfm
Maximum Pressure	80 kPa (0.8 kgf/cm <sup>2</sup> ) 0.8 bar 11.4 psig
Rated Voltage	12 V DC
Current (Mean Value)	0.74 A
Rated Performance (MTTF)	10,000 hours
Outlet	6 mm O.D. hose barb
Duty Cycle	Continuous
Coil Insulation Class	A or its equivalent
Mounting Dimensions	76 (L) x 70 (W) mm 2 - 63/64" (L) x 2 - 3/4" (W)
Weight	0.91 kg 2.01 Lbs
Leadwire Length	300 mm 11 - 13/16"

\*1: Airflow at rated pressure.

### Optional Accessory (LB07793)

Heavy duty rubber feet available on request.

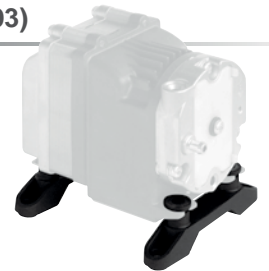

### Application Examples

Medical equipment, analyzers, etc.

### External Dimensions (Unit: mm)

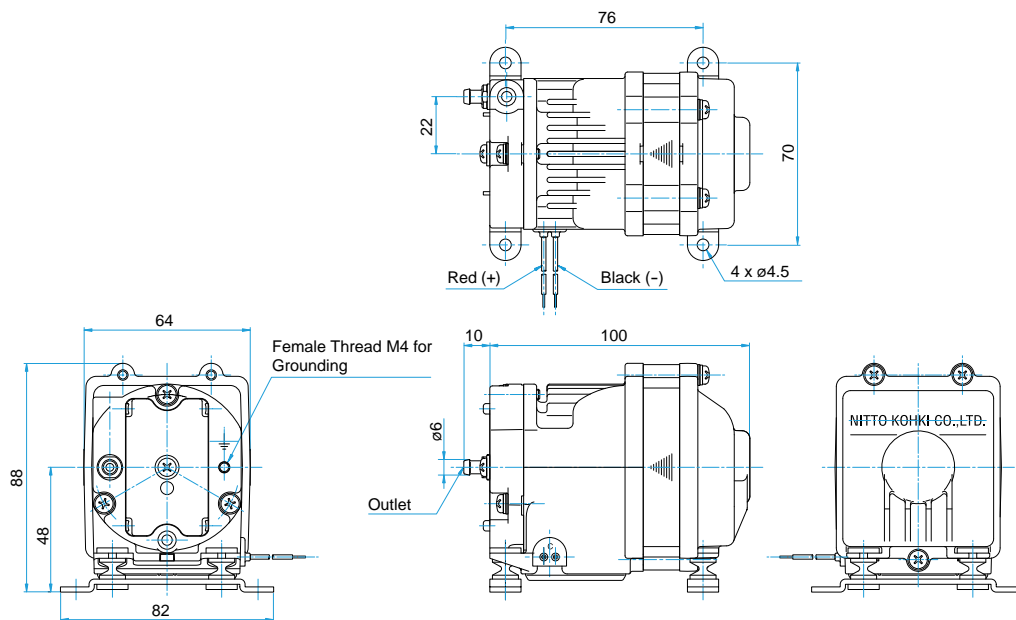



# Compressor

## Model **DAH105-Y1**

24 V DC

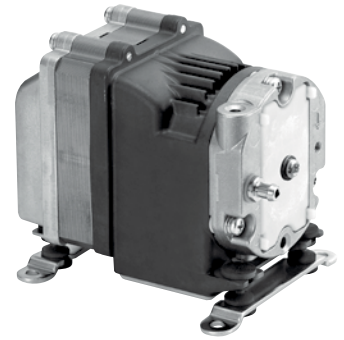

### Airflow & Electric Current

Airflow Characteristics

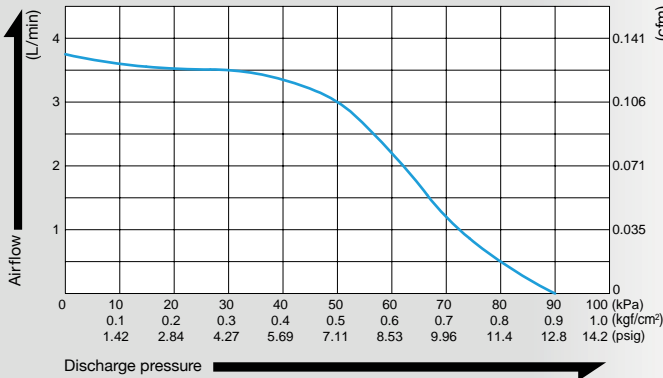

Current Characteristics

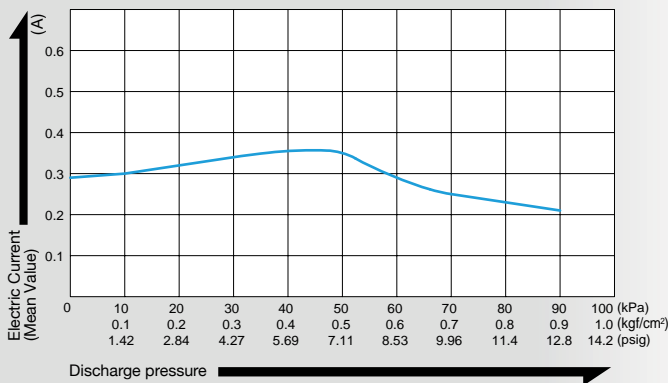

### Specifications

Rated Pressure	50 kPa (0.5 kgf/cm <sup>2</sup> ) 0.5 bar 7.11 psig
Rated Airflow	2.5 L/min *1 0.088 cfm
Maximum Pressure	80 kPa (0.8 kgf/cm <sup>2</sup> ) 0.8 bar 11.4 psig
Rated Voltage	24 V DC
Current (Mean Value)	0.35 A
Rated Performance (MTTF)	10,000 hours
Outlet	6 mm O.D. hose barb
Duty Cycle	Continuous
Coil Insulation Class	A or its equivalent
Mounting Dimensions	76 (L) x 70 (W) mm 2 - 63/64" (L) x 2 - 3/4" (W)
Weight	0.91 kg 2.01 Lbs
Leadwire Length	300 mm 11 - 13/16"

\*1: Airflow at rated pressure.

### Optional Accessory (LB07793)

Heavy duty rubber feet available on request.

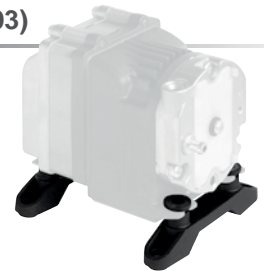

### Application Examples

Medical equipment, analyzers, etc.

### External Dimensions (Unit: mm)

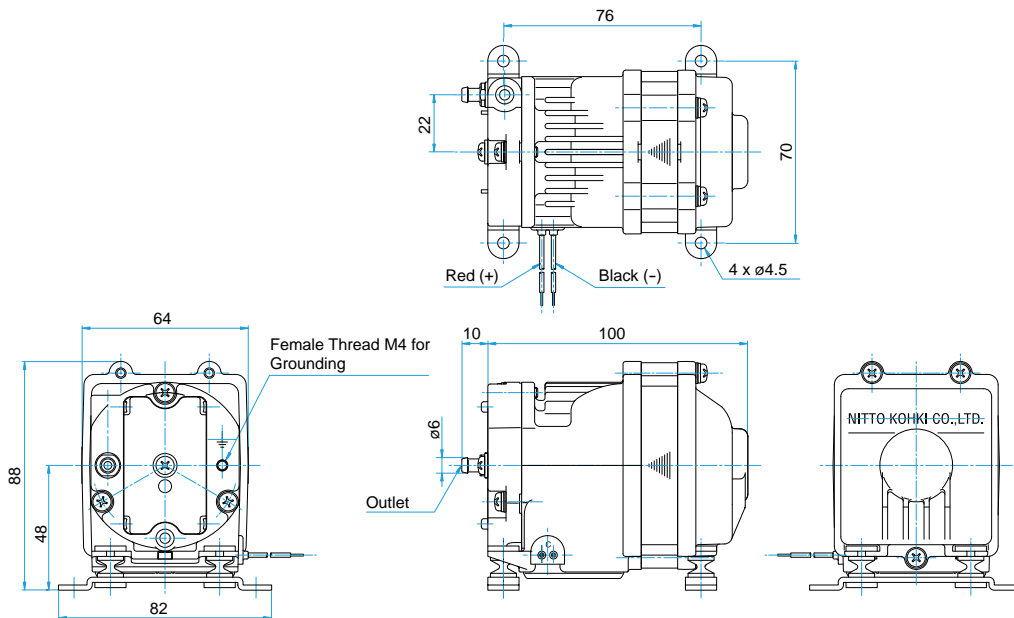

# Compressor

## Model **DAH110-X1**

12 V DC

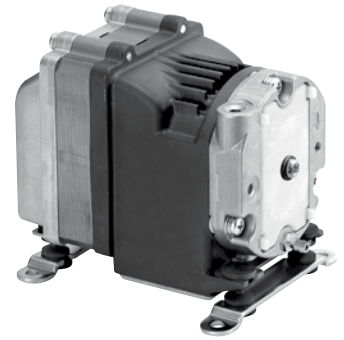

### Airflow & Electric Current

Airflow Characteristics

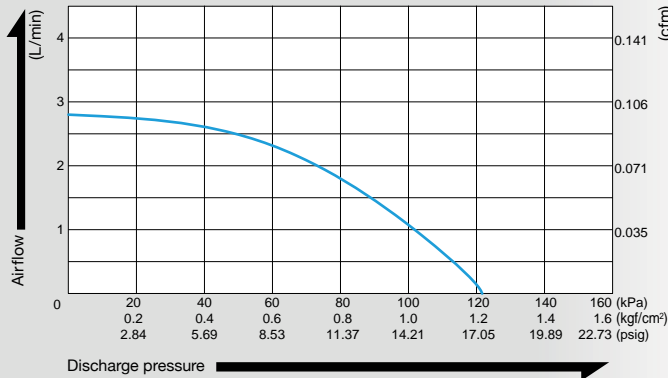

Current Characteristics

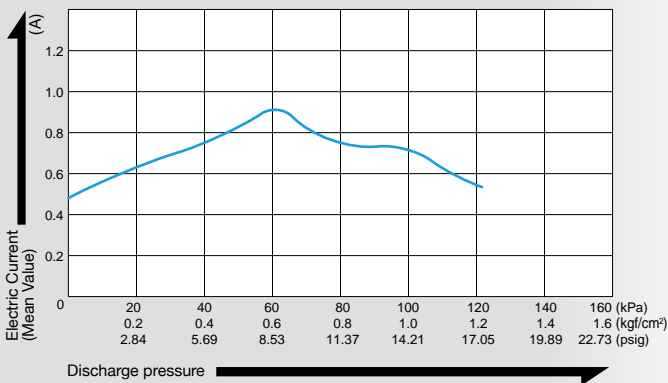

### Specifications

Rated Pressure	100 kPa (1.0 kgf/cm <sup>2</sup> ) 1.0 bar 14.2 psig
Rated Airflow	1.0 L/min *1 0.035 cfm
Maximum Pressure	120 kPa (1.2 kgf/cm <sup>2</sup> ) 1.2 bar 17.1 psig
Rated Voltage	12 V DC
Current (Mean Value)	0.74 A
Rated Performance (MTTF)	5,000 hours
Outlet	4.7 mm O.D. hose barb
Duty Cycle	Continuous
Coil Insulation Class	A or its equivalent
Mounting Dimensions	76 (L) x 70 (W) mm 2 - 63/64" (L) x 2 - 3/4" (W)
Weight	0.91 kg 2.01 Lbs
Leadwire Length	300 mm 11 - 13/16"

\*1: Airflow at rated pressure.

### Optional Accessory (LB07793)

Heavy duty rubber feet available on request.

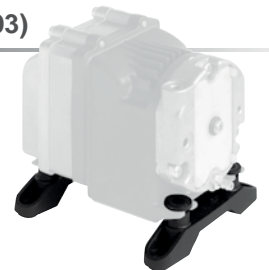

### Application Examples

Medical equipment, analyzers, etc.

### External Dimensions (Unit: mm)

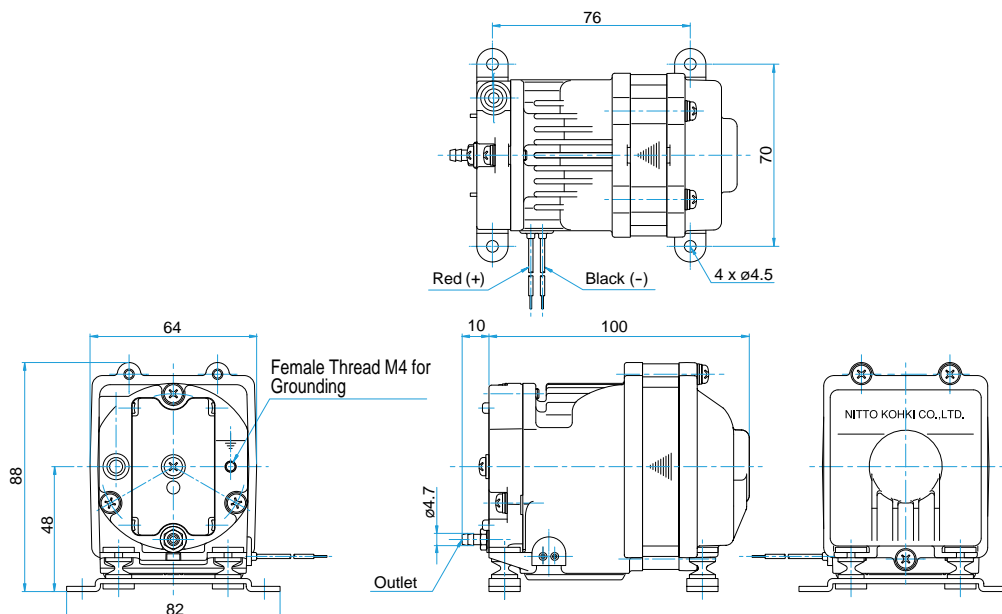

# Compressor

## Model **DAH110-Y1**

24 V DC

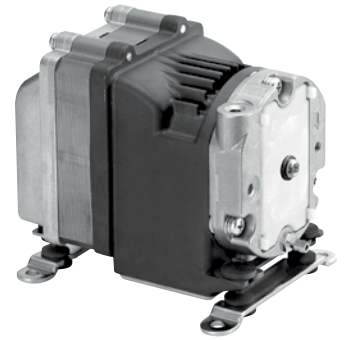

### Airflow & Electric Current

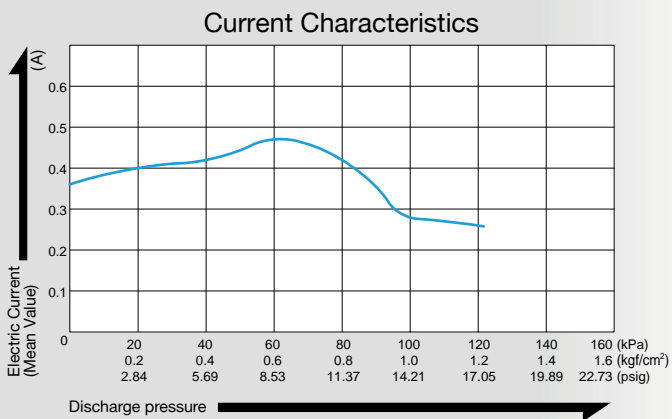
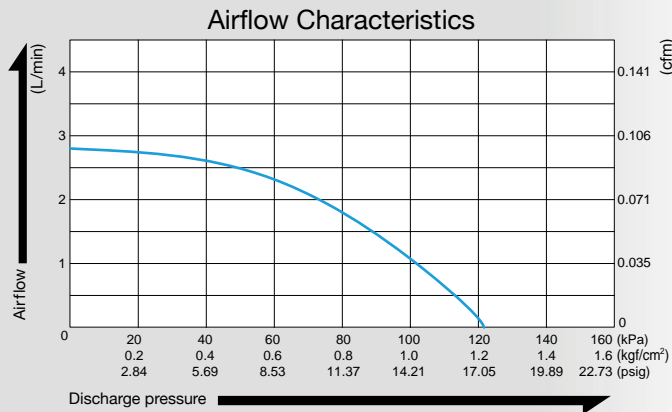

### Specifications

Rated Pressure	100 kPa (1.0 kgf/cm <sup>2</sup> ) 1.0 bar 14.2 psig
Rated Airflow	1.0 L/min *1 0.035 cfm
Maximum Pressure	120 kPa (1.2 kgf/cm <sup>2</sup> ) 1.2 bar 17.1 psig
Rated Voltage	24 V DC
Current (Mean Value)	0.27 A
Rated Performance (MTTF)	5,000 hours
Outlet	4.7 mm O.D. hose barb
Duty Cycle	Continuous
Coil Insulation Class	A or its equivalent
Mounting Dimensions	76 (L) x 70 (W) mm 2 - 63/64" (L) x 2 - 3/4" (W)
Weight	0.91 kg 2.01 Lbs
Leadwire Length	300 mm 11 - 13/16"

\*1: Airflow at rated pressure.

### Optional Accessory (LB07793)

Heavy duty rubber feet available on request.

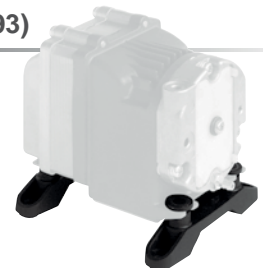

### Application Examples

Medical equipment, analyzers, etc.

### External Dimensions (Unit: mm)

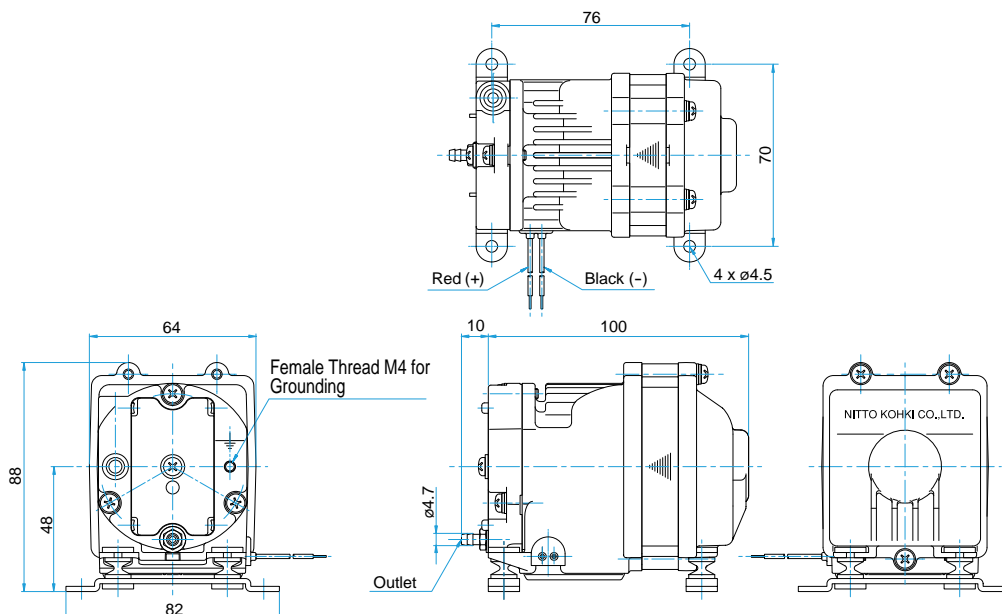



**DC LINEAR**  
Free Piston Vacuum Pump

# VACUUM PUMP

Page

DVH130-X1 — 45

DVH130-Y1 — 46

DVH145-X1 — 47

DVH145-Y1 — 48

## DVH series

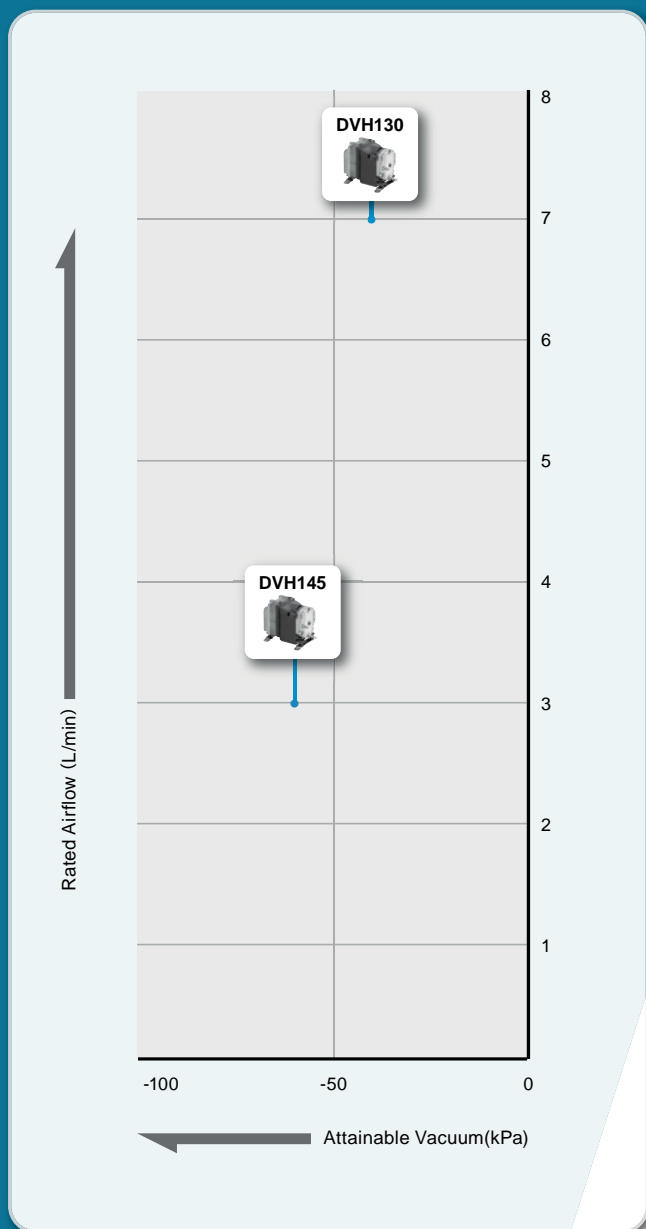

# Vacuum Pump

## Model DVH130-X1 12 V DC

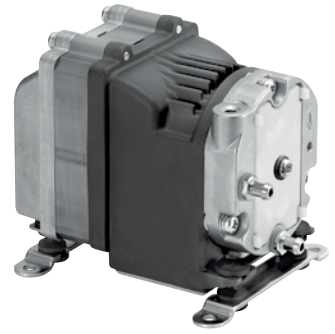

### Airflow & Electric Current

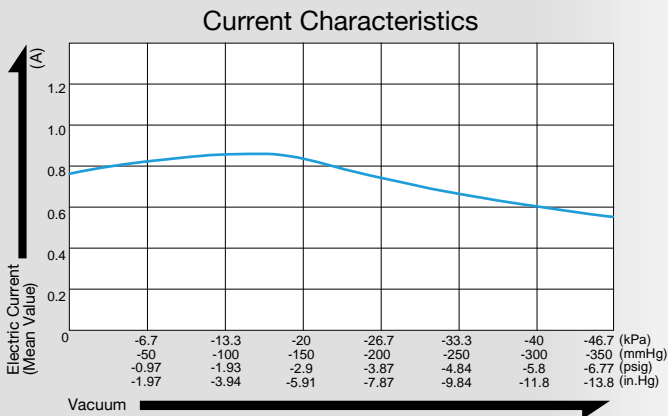
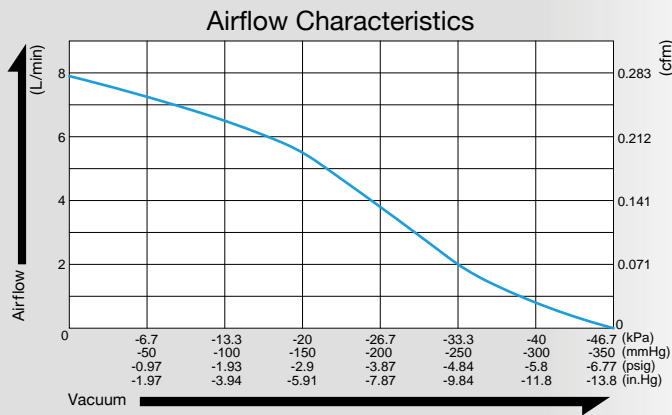

### Specifications

Attainable Vacuum	-40 kPa (-300 mmHg) -400 mbar -11.8 in. Hg
Free Air Displacement	7 L/min *1 0.247 cfm
Rated Voltage	12 V DC
Current (Mean Value)	0.86 A
Rated Performance (MTTF)	10,000 hours
Inlet	6 mm O.D. hose barb
Outlet	6 mm O.D. hose barb
Duty Cycle	Continuous
Coil Insulation Class	A or its equivalent
Mounting Dimensions	76 (L) x 70 (W) mm 2 - 63/64" (L) x 2 - 3/4" (W)
Weight	0.91 kg 2.01 Lbs
Leadwire Length	300 mm 11 - 13/16"

\*1: Free air displacement at no-load operation.

### Optional Accessory (LB07793)

Heavy duty rubber feet available on request.

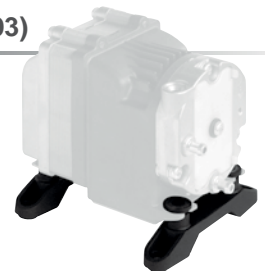

### Application Examples

Medical equipment, analyzers, etc.

### External Dimensions (Unit: mm)

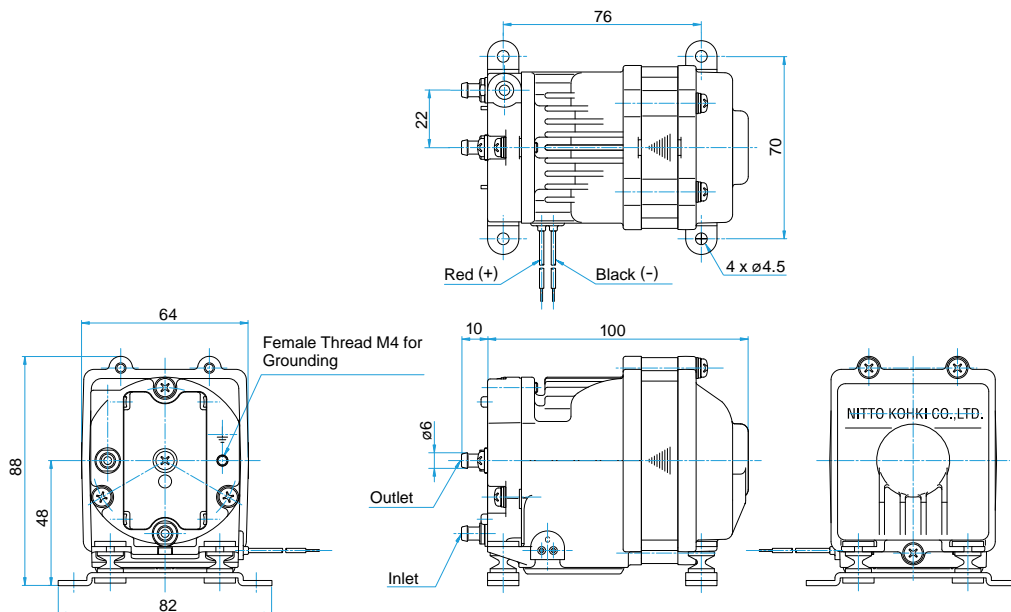

# Vacuum Pump

## Model DVH130-Y1

24 V DC

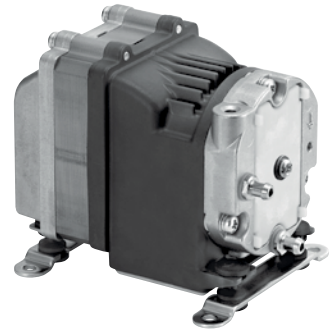

### Airflow & Electric Current

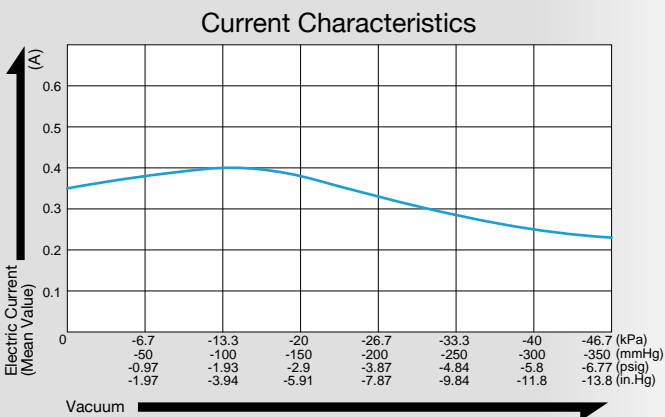
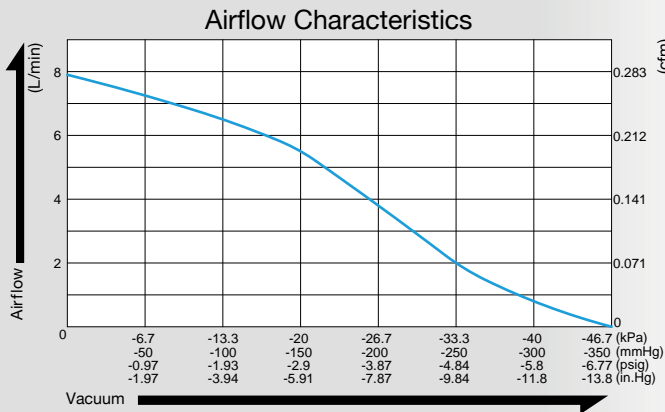

### Specifications

Attainable Vacuum	-40 kPa (-300 mmHg) -400 mbar -11.8 in. Hg
Free Air Displacement	7 L/min *1 0.247 cfm
Rated Voltage	24 V DC
Current (Mean Value)	0.41 A
Rated Performance (MTTF)	10,000 hours
Inlet	6 mm O.D. hose barb
Outlet	6 mm O.D. hose barb
Duty Cycle	Continuous
Coil Insulation Class	A or its equivalent
Mounting Dimensions	76 (L) x 70 (W) mm 2 - 63/64" (L) x 2 - 3/4" (W)
Weight	0.91 kg 2.01 Lbs
Leadwire Length	300 mm 11 - 13/16"

\*1: Free air displacement at no-load operation.

### Optional Accessory (LB07793)

Heavy duty rubber feet available on request.

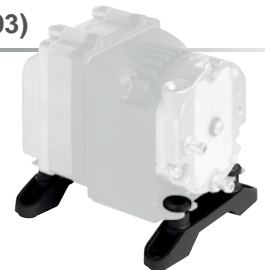

### Application Examples

Medical equipment, analyzers, etc.

### External Dimensions (Unit: mm)

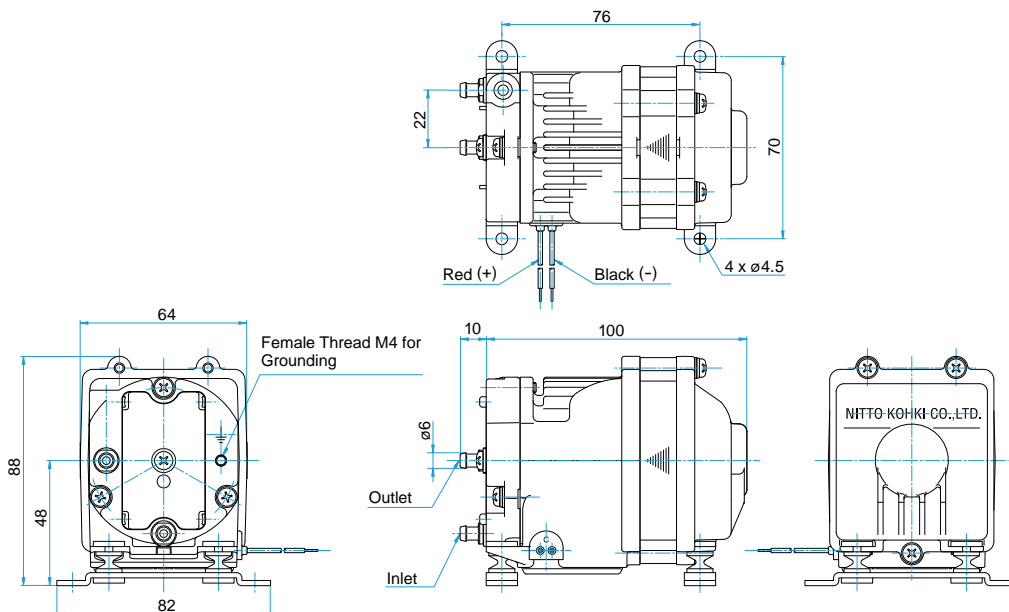

# Vacuum Pump

## Model DVH145-X1

12 V DC

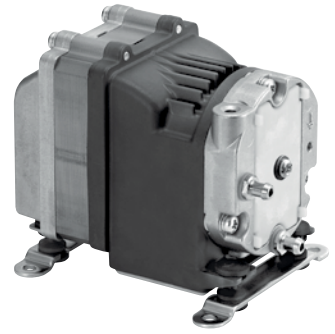

### Airflow & Electric Current

Airflow Characteristics

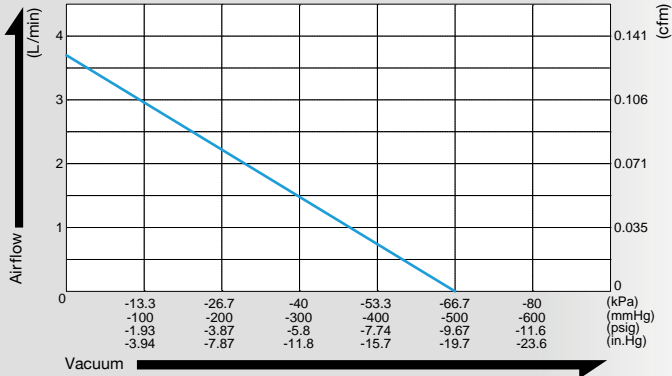

Current Characteristics

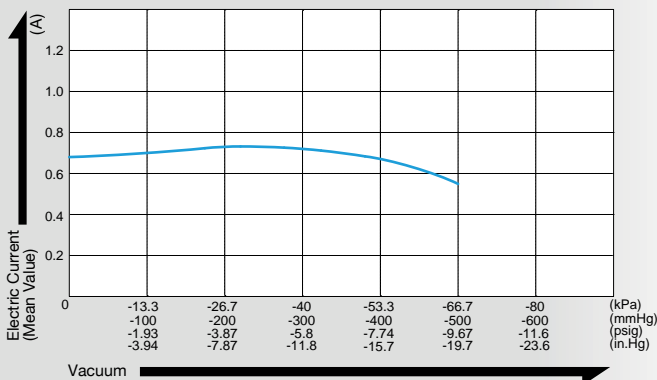

### Specifications

Attainable Vacuum	-60 kPa (-450 mmHg) -600 mbar -17.7 in. Hg
Free Air Displacement	3 L/min *1 0.106 cfm
Rated Voltage	12 V DC
Current (Mean Value)	0.73 A
Rated Performance (MTTF)	10,000 hours
Inlet	6 mm O.D. hose barb
Outlet	6 mm O.D. hose barb
Duty Cycle	Continuous
Coil Insulation Class	A or its equivalent
Mounting Dimensions	76 (L) x 70 (W) mm 2 - 63/64" (L) x 2 - 3/4" (W)
Weight	0.91 kg 2.01 Lbs
Leadwire Length	300 mm 11 - 13/16"

\*1: Free air displacement at no-load operation.

### Optional Accessory (LB07793)

Heavy duty rubber feet available on request.

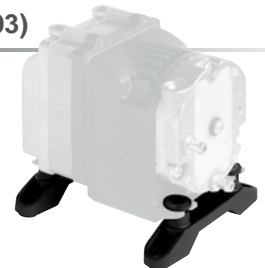

### Application Examples

Medical equipment, analyzers, etc.

### External Dimensions (Unit: mm)

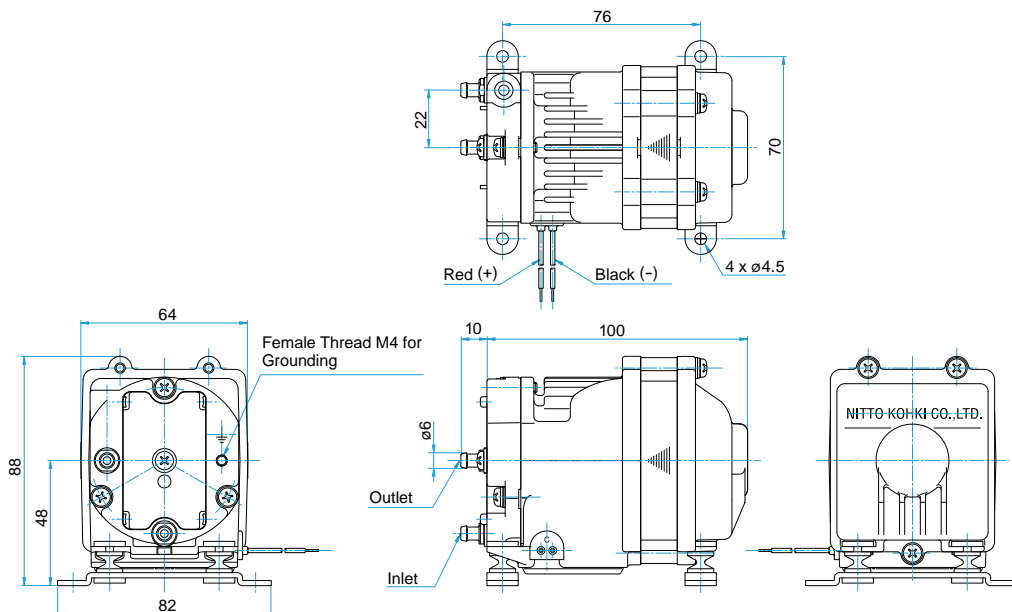



# Vacuum Pump

## Model DVH145-Y1

24 V DC

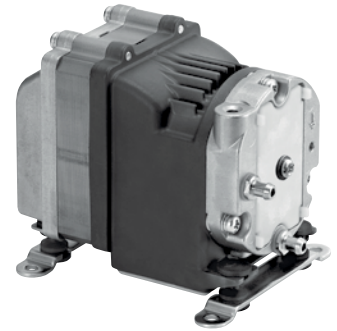

### Airflow & Electric Current

Airflow Characteristics

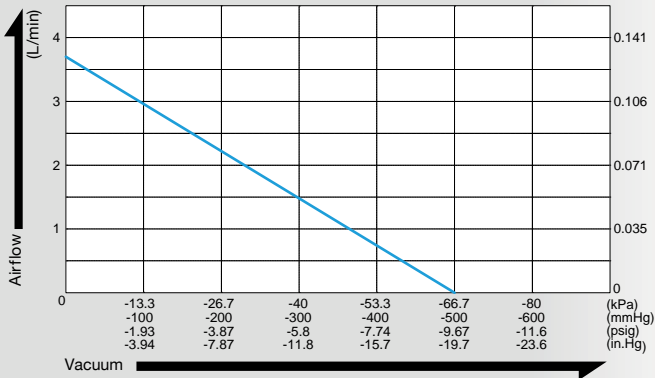

Current Characteristics

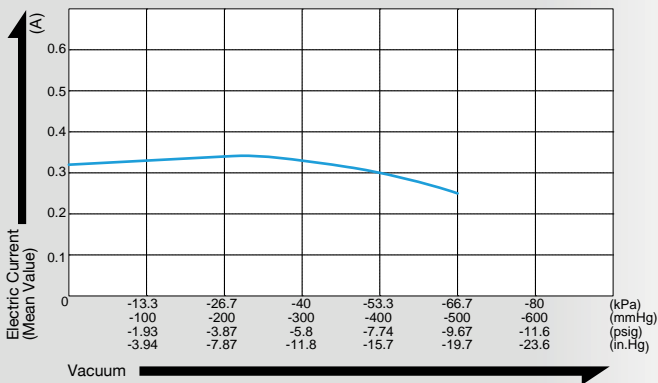

### Specifications

Attainable Vacuum	-60 kPa (-450 mmHg) -600 mbar -17.7 in. Hg
Free Air Displacement	3 L/min *1 0.106 cfm
Rated Voltage	24 V DC
Current (Mean Value)	0.34 A
Rated Performance (MTTF)	10,000 hours
Inlet	6 mm O.D. hose barb
Outlet	6 mm O.D. hose barb
Duty Cycle	Continuous
Coil Insulation Class	A or its equivalent
Mounting Dimensions	76 (L) x 70 (W) mm 2 - 63/64" (L) x 2 - 3/4" (W)
Weight	0.91 kg 2.01 Lbs
Leadwire Length	300 mm 11 - 13/16"

\*1: Free air displacement at no-load operation.

### Optional Accessory (LB07793)

Heavy duty rubber feet available on request.

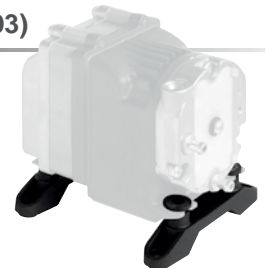

### Application Examples

Medical equipment, analyzers, etc.

### External Dimensions (Unit: mm)

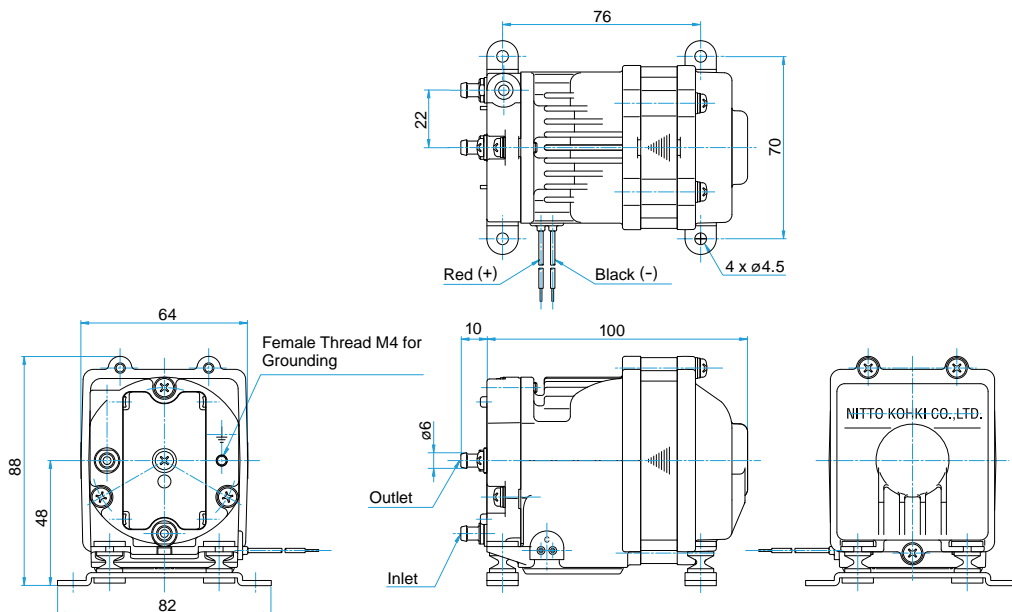



# DIAPHRAGM PUMP

**VC series**

VC0100	Dual Type	— 51
VC0100	Blower Type	— 52
VC0101	Dual Type	— 53
VC0101	Blower Type	— 54
VC0101S	Blower Type	— 55
VC0201B	Dual Type	— 56
VC0201B	Blower Type	— 57
VC0301B	Dual Type	— 58
VC0301B	Blower Type	— 59

**Made to Order**

VCK0120	Vacuum Pump Type	— 107
VC0101E	Dual Type	— 108
VC0101E	Blower Type	— 109
VC0101S	Dual Type	— 110

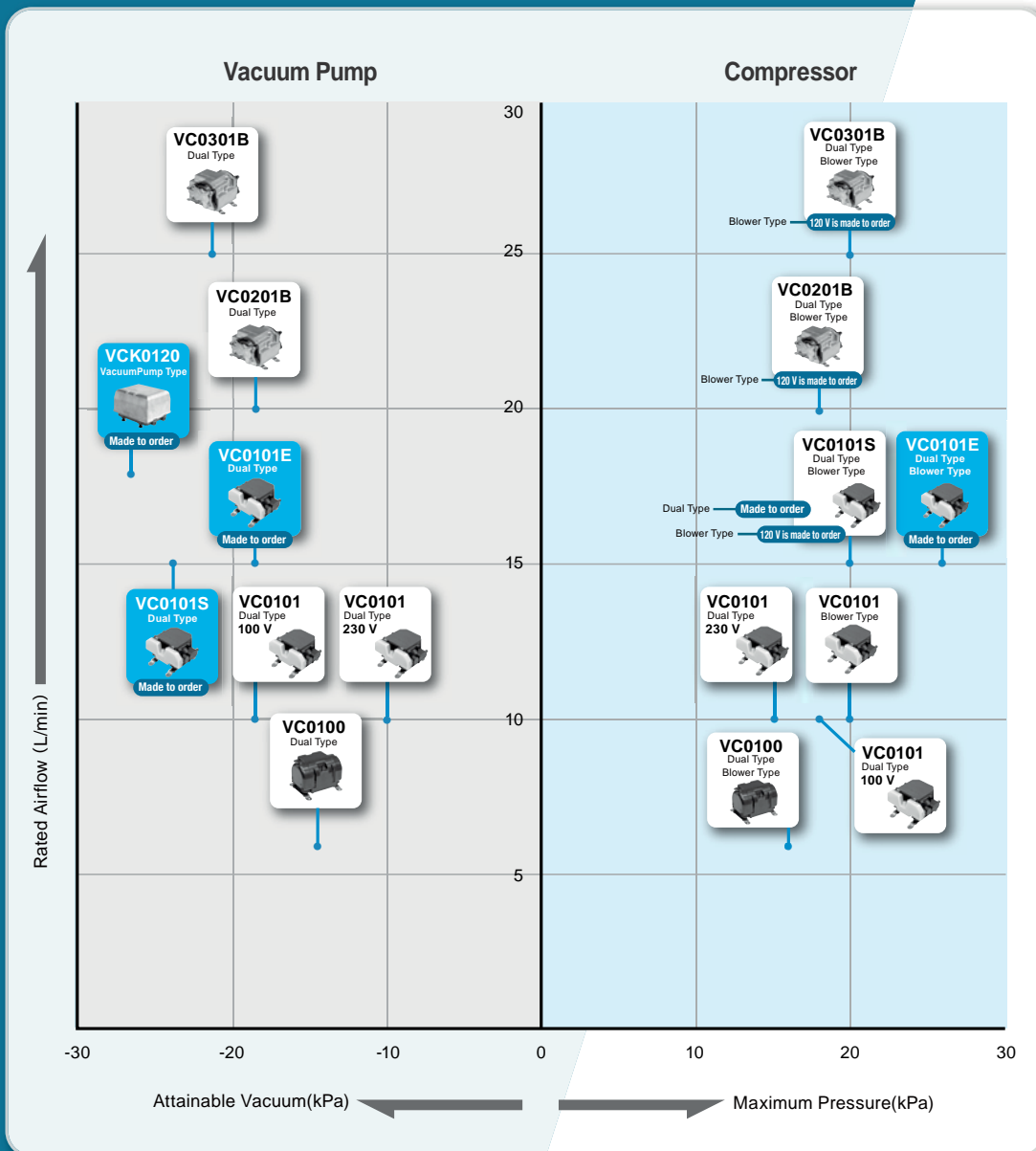

# Compressor and Vacuum Pump

## Model VC0100

Dual Type

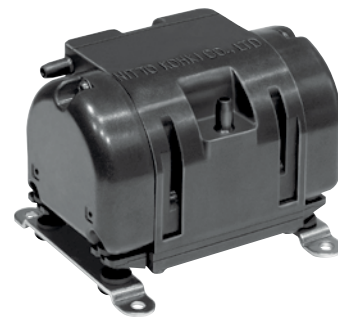

### Airflow & Power Consumption

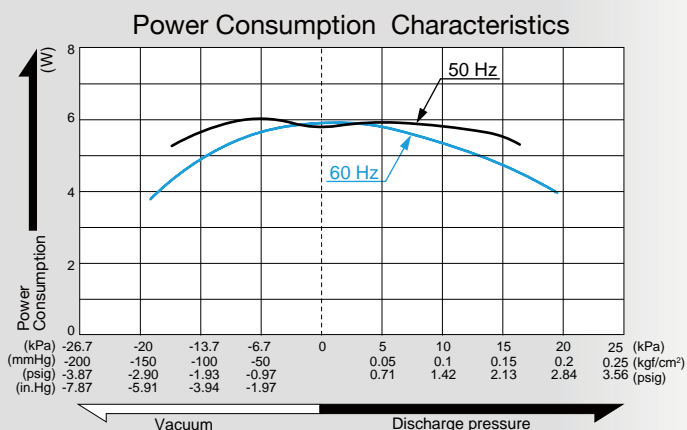
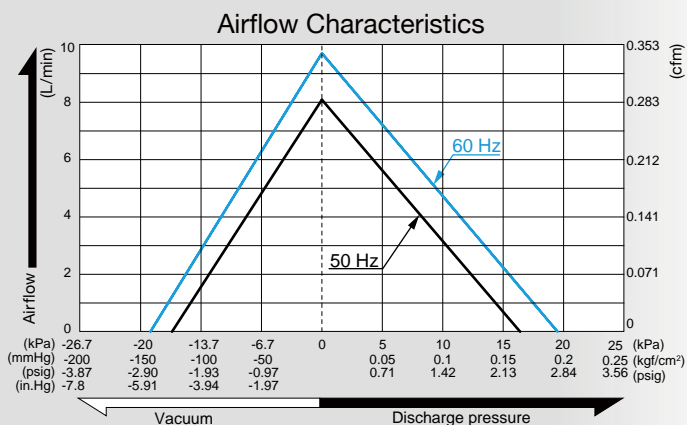

### Specifications

Rated Pressure	4 kPa (0.04 kgf/cm <sup>2</sup> ) 0.04 bar 0.57 psig	
Rated Airflow	6 L/min 0.212 cfm	
Maximum Pressure	16 kPa (0.16 kgf/cm <sup>2</sup> ) 0.16 bar 2.28 psig	
Attainable Vacuum	-14.7 kPa (-110 mmHg) -147 mbar -4.33 in.Hg	
Rated Voltage	120 V AC	230 V AC
Power Consumption	6 W	
Rated Frequency	60 Hz	50 Hz
Rated Performance	5,000 hours	
Working Pressure Range	-14.7 kPa to 16 kPa (-110 mmHg to 0.16 kgf/cm <sup>2</sup> ) -147 mbar to 0.16 bar -4.33 in.Hg to 2.28 psig	
Inlet	6 mm O.D. hose barb	
Outlet	6 mm O.D. hose barb	
Duty Cycle	Continuous	
Coil Insulation Class	A for 120 V or its equivalent	E for 230 V or its equivalent
Mounting Dimensions	70 (L) x 72 (W) mm 2 - 3/4" (L) x 2 - 53/64" (W)	
Weight	0.45 kg 0.99 Lbs	
Leadwire Length	300 mm 11 - 13/16"	

### Application Examples

Massage Devices

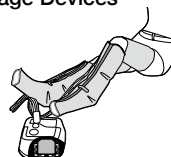

Bedsore Prevention Mattress



### External Dimensions (Unit: mm)

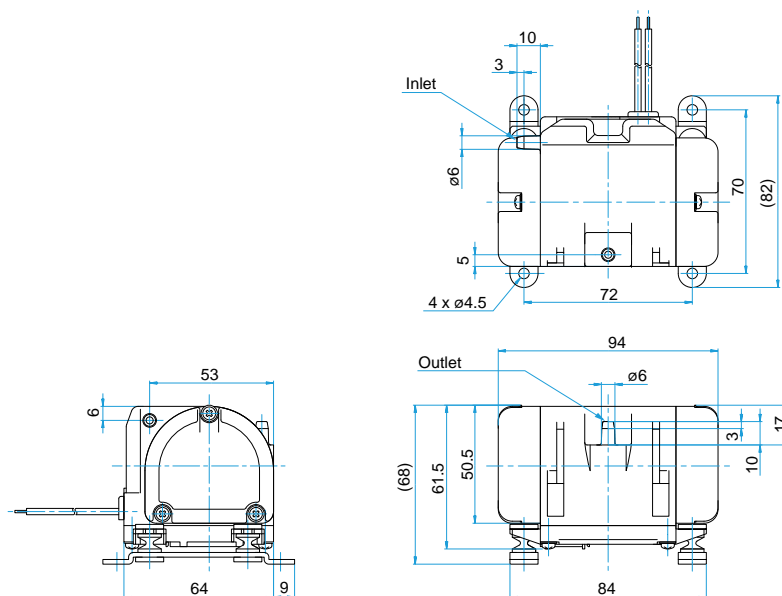

# Compressor

## Model VC0100

Blower Type



### Airflow & Power Consumption

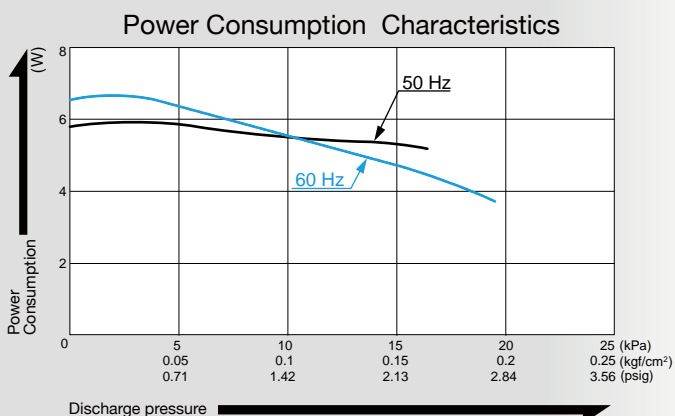
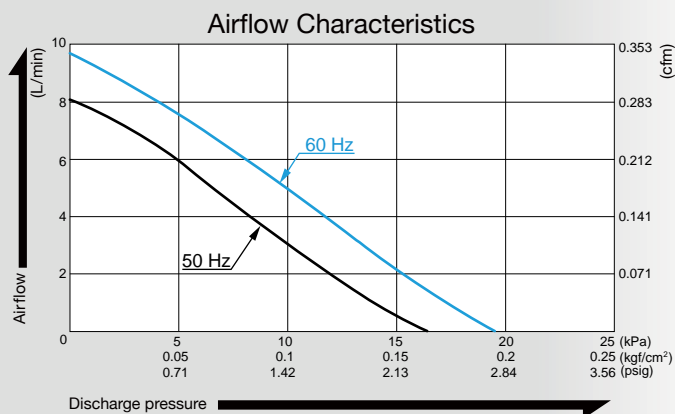

### Specifications

Rated Pressure	4 kPa (0.04 kgf/cm <sup>2</sup> ) 0.04 bar 0.57 psig	
Rated Airflow	6 L/min 0.212 cfm	
Maximum Pressure	16 kPa (0.16 kgf/cm <sup>2</sup> ) 0.16 bar 2.28 psig	
Rated Voltage	120 V AC	230 V AC
Power Consumption	6 W	
Rated Frequency	60 Hz	50 Hz
Rated Performance	10,000 hours	
Working Pressure Range	0 to 16 kPa (0 to 0.16 kgf/cm <sup>2</sup> ) 0 to 0.16 bar 0 to 2.28 psig	
Outlet	6 mm O.D. hose barb	
Duty Cycle	Continuous	
Coil Insulation Class	A for 120 V or its equivalent   E for 230 V or its equivalent	
Mounting Dimensions	70 (L) x 72 (W) mm 2 - 3/4" (L) x 2 - 53/64" (W)	
Weight	0.45 kg 0.99 Lbs	
Leadwire Length	300 mm 11 - 13/16"	

### Application Examples

Massage Devices

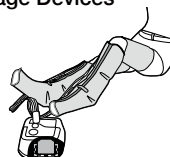

Bedsore Prevention Mattress



### External Dimensions (Unit: mm)

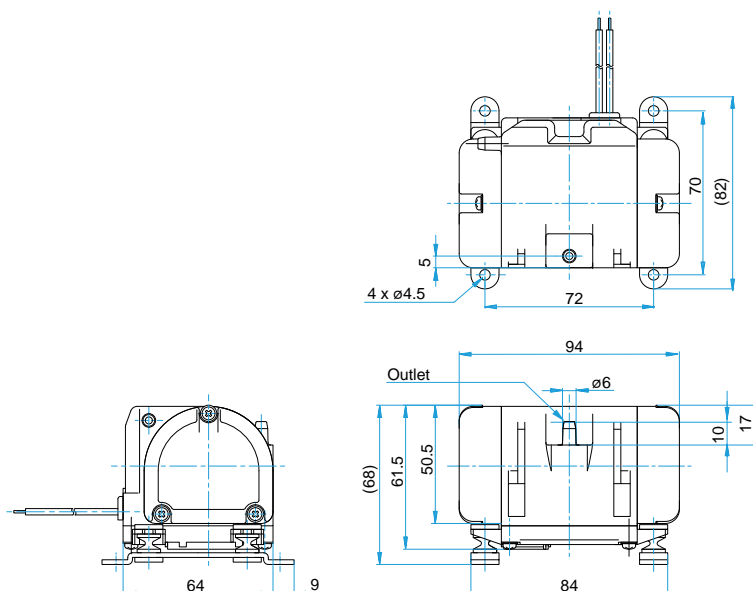

# Compressor and Vacuum Pump

## Model VC0101

Dual Type

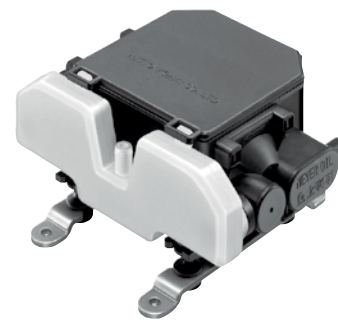

### Airflow & Power Consumption

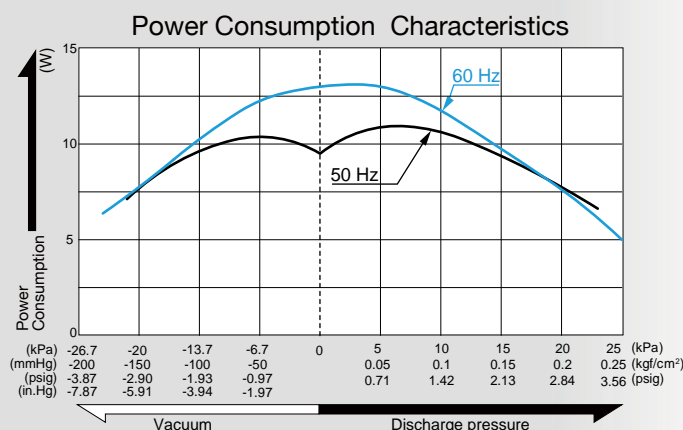
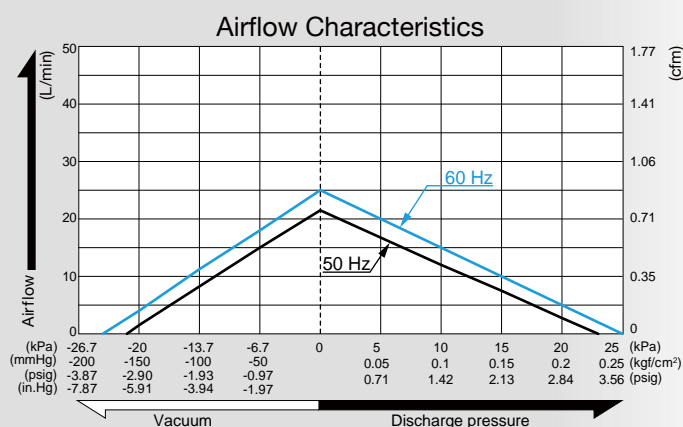

### Specifications

Rated Pressure	10 kPa (0.1 kgf/cm <sup>2</sup> ) 0.1 bar 1.42 psig	
Rated Airflow	10 L/min 0.35 cfm	
Rated Voltage	120 V AC	230 V AC
Maximum Pressure	18 kPa (0.18 kgf/cm <sup>2</sup> ) 0.18 bar 2.56 psig	15 kPa (0.15 kgf/cm <sup>2</sup> ) 0.15 bar 2.13 psig
Attainable Vacuum	-18.7 kPa (-140 mmHg) -187 mbar -5.51 in.Hg	-10 kPa (-76 mmHg) -100 mbar -2.95 in.Hg
Working Pressure Range	-18.7 kPa to 18 kPa (-140 mmHg to 0.18 kgf/cm <sup>2</sup> ) -187 mbar to 0.18 bar -5.51 in.Hg to 2.56 psig	-10 kPa to 15 kPa (-76 mmHg to 0.15 kgf/cm <sup>2</sup> ) -100 mbar to 0.15 bar -2.95 in.Hg to 2.13 psig
Power Consumption	11 W	
Rated Frequency	60 Hz	50 Hz
Rated Performance	5,000 hours	
Inlet	7.5 mm O.D. hose barb	
Outlet	7.5 mm O.D. hose barb	
Duty Cycle	Continuous	
Coil Insulation Class	B for 120 V or its equivalent	B for 230 V or its equivalent
Mounting Dimensions	66 (L) x 100 (W) mm 2 - 19/32" (L) x 2 - 15/16" (W)	
Weight	0.82 kg 1.81 Lbs	
Leadwire Length	200 mm 11 - 13/16"	

### Application Examples

Massage Devices

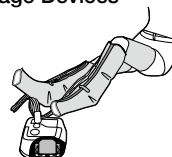

Bedsore Prevention Mattress



### External Dimensions (Unit: mm)

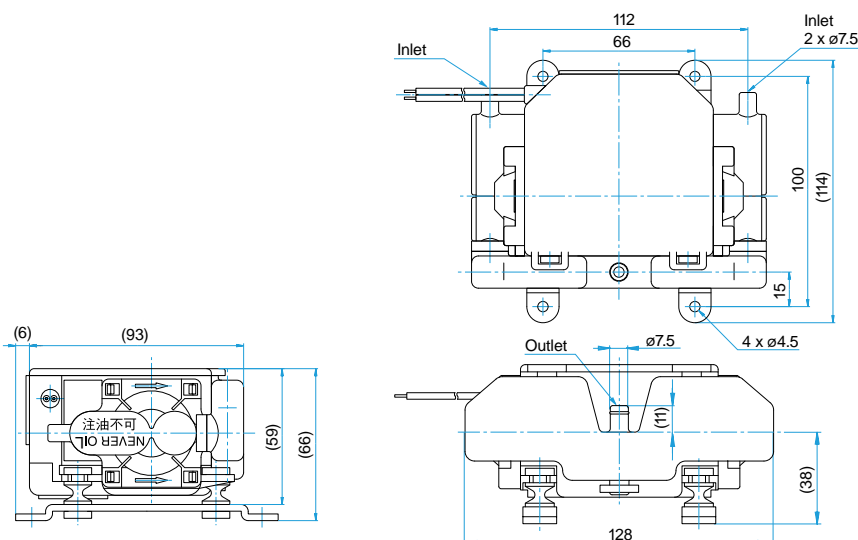

# Compressor

## Model VC0101

Blower Type

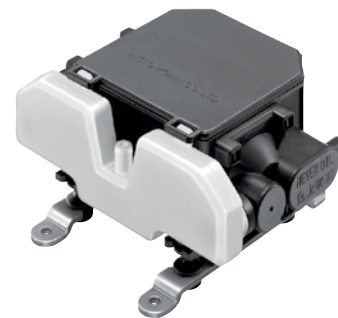

### Airflow & Power Consumption

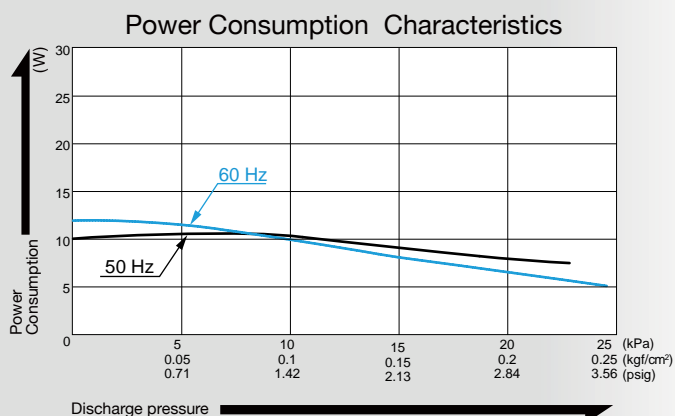
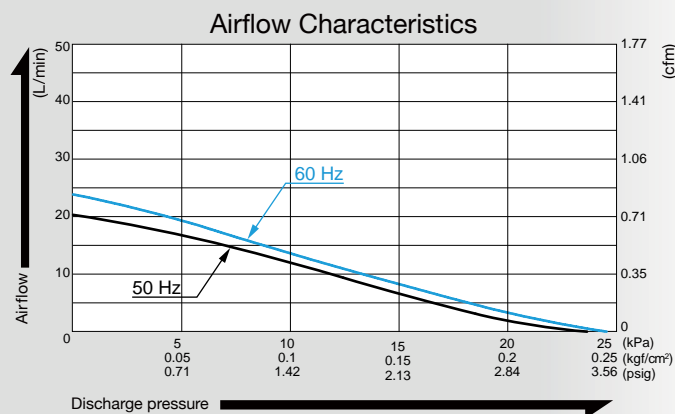

### Specifications

Rated Pressure	10 kPa (0.1 kgf/cm <sup>2</sup> ) 0.1 bar 1.42 psig	
Rated Airflow	10 L/min 0.35 cfm	
Maximum Pressure	20 kPa (0.2 kgf/cm <sup>2</sup> ) 0.2 bar 2.84 psig	
Rated Voltage	120 V AC	230 V AC
Power Consumption	11 W	
Rated Frequency	60 Hz	50 Hz
Rated Performance	10,000 hours	
Working Pressure Range	0 to 20 kPa (0 to 0.2 kgf/cm <sup>2</sup> ) 0 to 0.2 bar 0 to 2.84 psig	
Outlet	7.5 mm O.D. hose barb	
Duty Cycle	Continuous	
Coil Insulation Class	A for 120 V or its equivalent	E for 230 V or its equivalent
Mounting Dimensions	66 (L) x 100 (W) mm 2 - 19/32" (L) x 3 - 15/16" (W)	
Weight	0.82 kg 1.81 Lbs	
Leadwire Length	300 mm 7 - 7/8"	

### Application Examples

Massage Devices



Bedsore Prevention Mattress



### External Dimensions (Unit: mm)

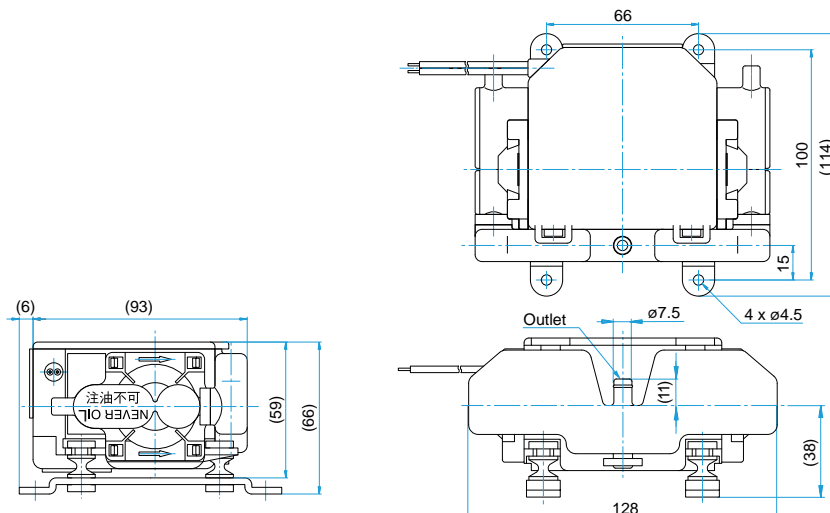

# Compressor

## Model VC0101S

120 V is made to order

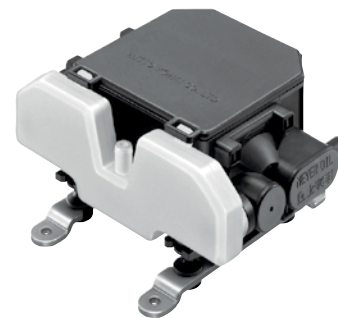

### Blower Type



#### Airflow & Power Consumption

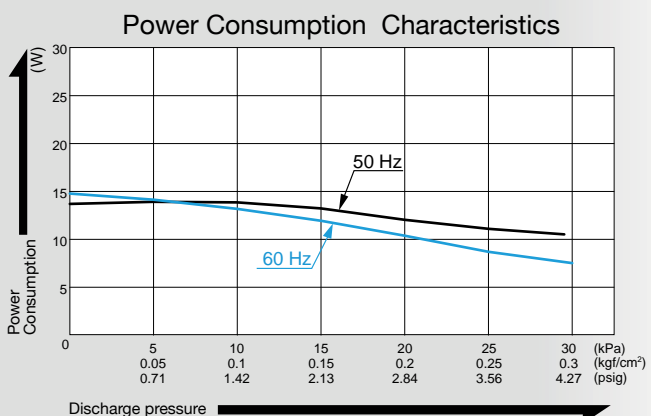
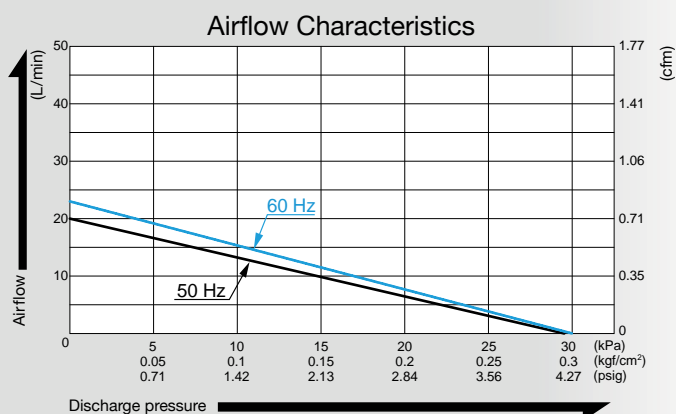

#### Specifications

Rated Pressure	5 kPa (0.05 kgf/cm <sup>2</sup> ) 0.05 bar 0.71 psig	
Rated Airflow	15 L/min 0.53 cfm	
Maximum Pressure	26 kPa (0.26 kgf/cm <sup>2</sup> ) 0.26 bar 3.70 psig	
Rated Voltage	120 V AC *1	230 V AC
Power Consumption	14 W	
Rated Frequency	60 Hz	50 Hz
Rated Performance	5,000 hours	
Working Pressure Range	0 to 26 kPa (0 to 0.26 kgf/cm <sup>2</sup> ) 0 to 0.26 bar 0 to 3.70 psig	
Outlet	7.5 mm O.D. hose barb	
Duty Cycle	60 minutes	
Coil Insulation Class	B or its equivalent	
Mounting Dimensions	66 (L) x 100 (W) mm 2 - 19/32" (L) x 3 - 15/16" (W)	
Weight	0.83 kg 1.81 Lbs	
Leadwire Length	300 mm 11 - 13/16"	

\*1: Non-UL product. 120 V is made to order.

#### Application Examples

Massage Devices

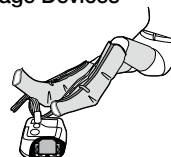

Bedsore Prevention Mattress



#### External Dimensions (Unit: mm)

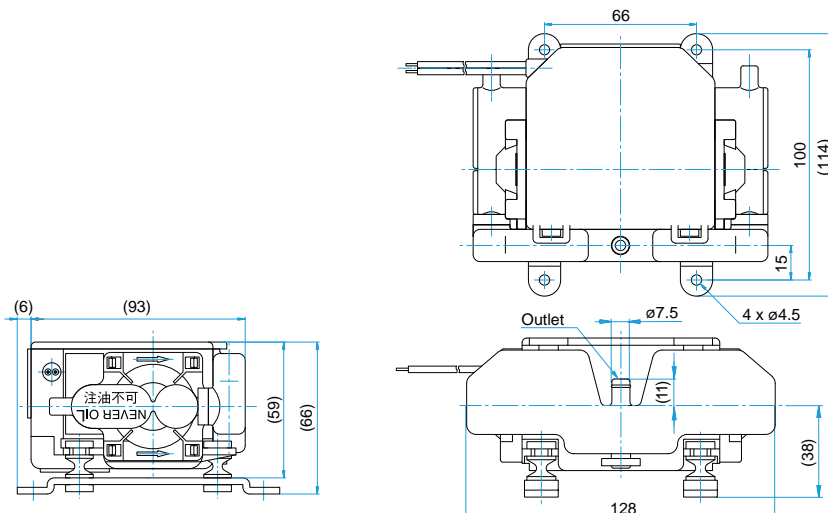



# Compressor and Vacuum Pump

## Model VC0201B

Dual Type

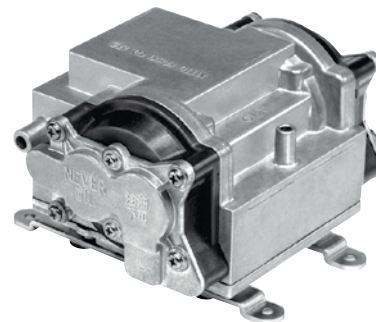

### Airflow & Power Consumption

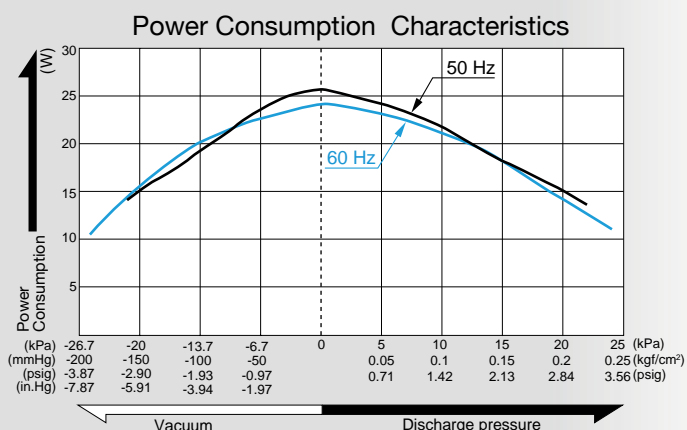
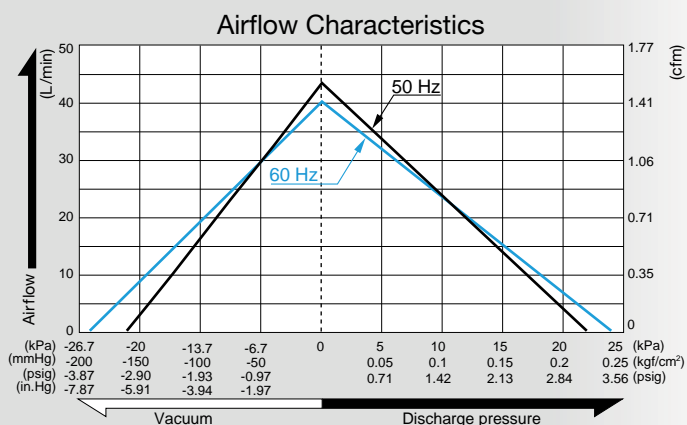

### Specifications

Rated Pressure	10 kPa (0.1 kgf/cm <sup>2</sup> ) 0.1 bar 1.42 psig	
Rated Airflow	20 L/min 0.71 cfm	
Maximum Pressure	18 kPa (0.18 kgf/cm <sup>2</sup> ) 0.18 bar 2.56 psig	
Attainable Vacuum	-18.7 kPa (-140 mmHg) -187 mbar -5.51 in.Hg	
Rated Voltage	120 V AC	230 V AC
Power Consumption	21 W	
Rated Frequency	60 Hz	50 Hz
Rated Performance	10,000 hours	
Working Pressure Range	-18.7 kPa to 18 kPa (-140 mmHg to 0.18 kgf/cm <sup>2</sup> ) -187 mbar to 0.18 bar -5.51 in.Hg to 2.56 psig	
Inlet	10.5 mm O.D. hose barb	
Outlet	8.5 mm O.D. hose barb	
Duty Cycle	Continuous	
Coil Insulation Class	E or its equivalent and A for UL	
Mounting Dimensions	125 (L) x 56 (W) mm 4 - 59/64" (L) x 2 - 13/64" (W)	
Weight	1.7 kg 3.7 Lbs	
Leadwire Length	300 mm 11 - 13/16"	

### Application Examples

Bedsore Prevention  
Mattress

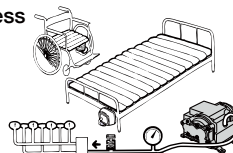

Solder Fume Suction

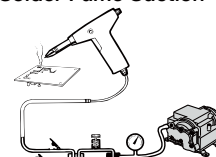

### External Dimensions (Unit: mm)

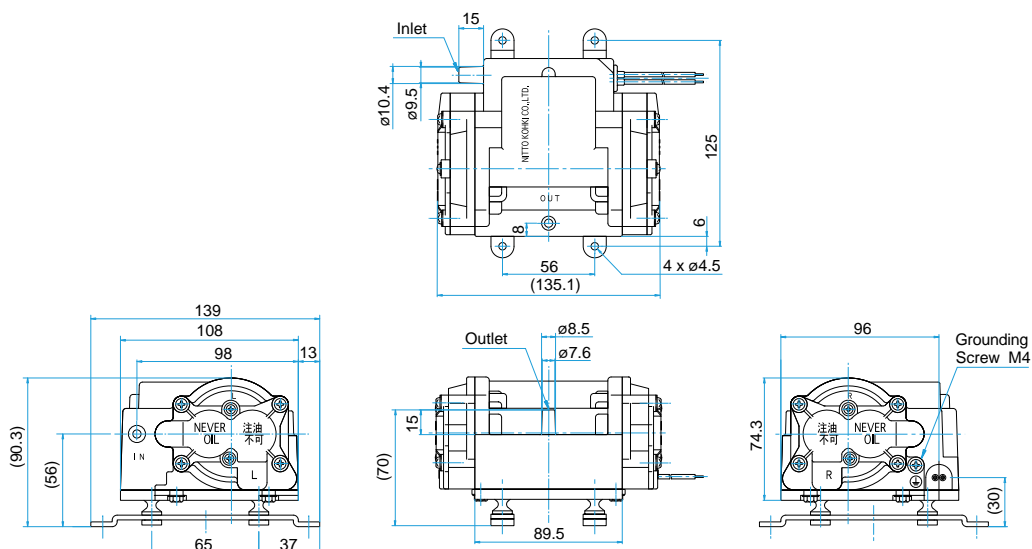

# Compressor

## Model VC0201B

120 V is made to order

### Blower Type

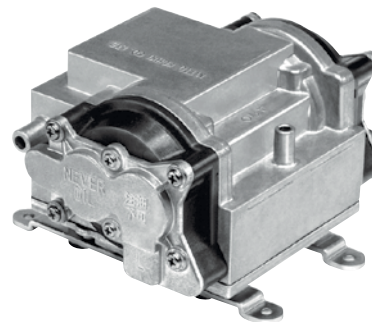

#### Airflow & Power Consumption

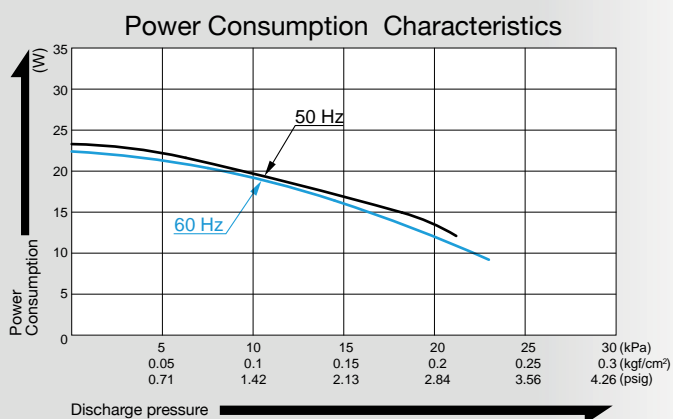
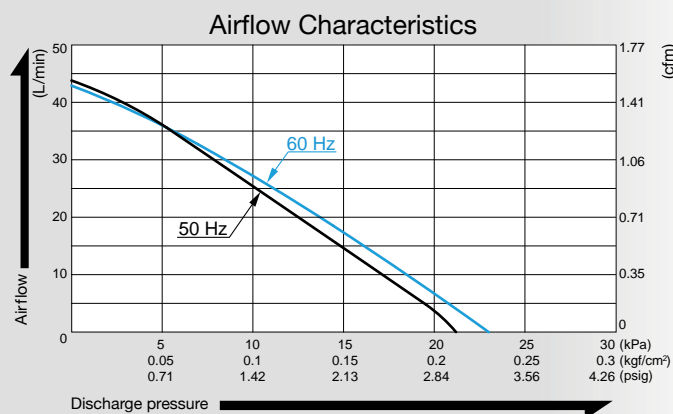

#### Specifications

Rated Pressure	10 kPa (0.1 kgf/cm <sup>2</sup> ) 0.1 bar 1.42 psig	
Rated Airflow	20 L/min 0.71 cfm	
Maximum Pressure	18 kPa (0.18 kgf/cm <sup>2</sup> ) 0.18 bar 2.56 psig	
Rated Voltage	120 V AC	230 V AC
Power Consumption	21 W	
Rated Frequency	60 Hz	50 Hz
Rated Performance	10,000 hours	
Working Pressure Range	0 to 18 kPa (0 to 0.18 kgf/cm <sup>2</sup> ) 0 to 0.18 bar 0 to 2.56 psig	
Outlet	8.5 mm O.D. hose barb	
Duty Cycle	Continuous	
Coil Insulation Class	E or its equivalent and A for UL	
Mounting Dimensions	125 (L) x 56 (W) mm 4 - 59/64" (L) x 2 - 13/64" (W)	
Weight	1.7 kg 3.7 Lbs	
Leadwire Length	300 mm 11 - 13/16"	

#### Application Examples

##### Bedsore Prevention Mattress

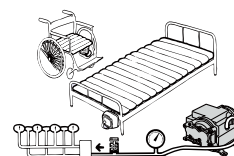

#### External Dimensions (Unit: mm)

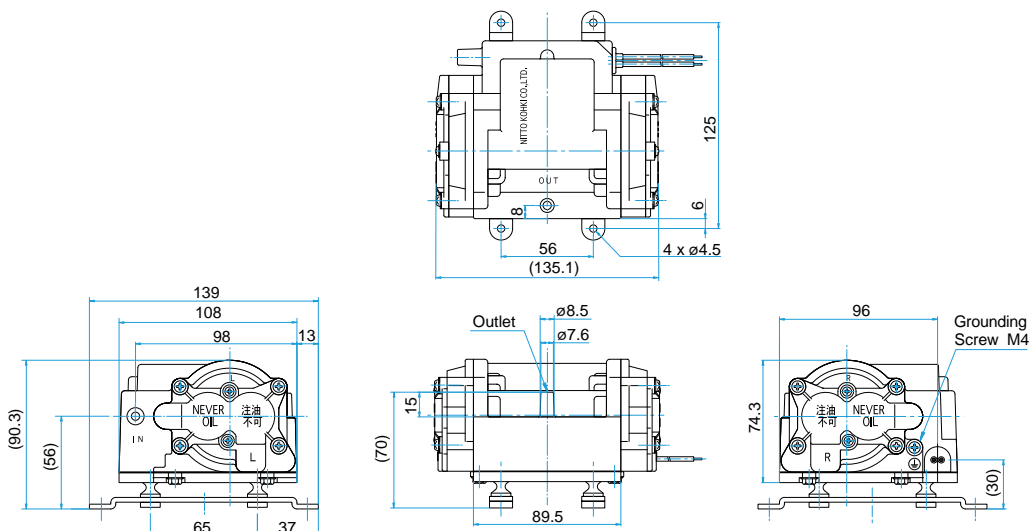

# Compressor and Vacuum Pump

## Model VC0301B

Dual Type

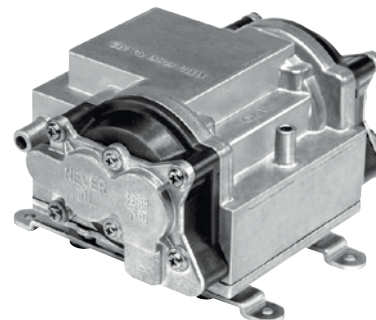

### Airflow & Power Consumption

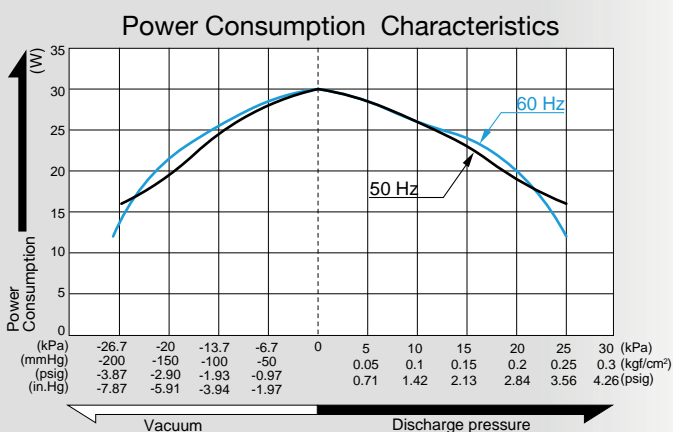
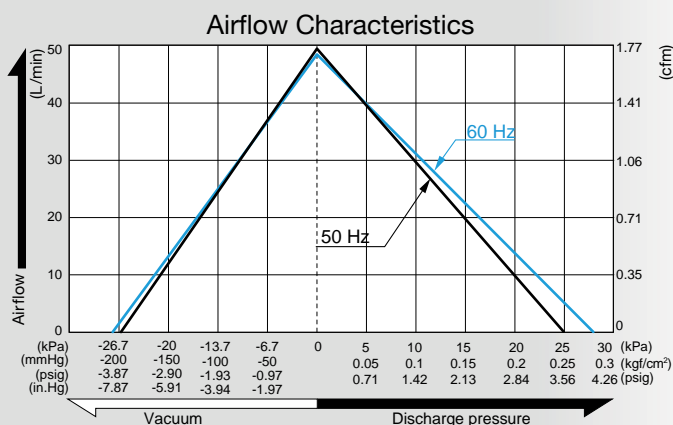

### Specifications

Rated Pressure	10 kPa (0.1 kgf/cm <sup>2</sup> ) 0.1 bar 1.42 psig	
Rated Airflow	25 L/min 0.88 cfm	
Maximum Pressure	20 kPa (0.2 kgf/cm <sup>2</sup> ) 0.2 bar 2.84 psig	
Attainable Vacuum	-21.3 kPa (-160 mmHg) -213 mbar -6.3 in.Hg	
Rated Voltage	120 V AC	230 V AC
Power Consumption	27 W	
Rated Frequency	60 Hz	50 Hz
Rated Performance	10,000 hours	
Working Pressure Range	-21.3 kPa to 20 kPa (-160 mmHg to 0.2 kgf/cm <sup>2</sup> ) -213 mbar to 0.2 bar -6.3 in.Hg to 2.84 psig	
Inlet	10.5 mm O.D. hose barb	
Outlet	8.5 mm O.D. hose barb	
Duty Cycle	Continuous	
Coil Insulation Class	B or its equivalent	
Mounting Dimensions	125 (L) x 56 (W) mm 4 - 59/64" (L) x 2 - 13/64" (W)	
Weight	1.7 kg 3.7 Lbs	
Leadwire Length	300 mm 11 - 13/16"	

### Application Examples

Bedsore Prevention  
Mattress

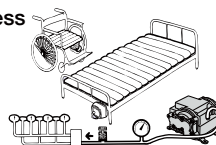

Solder Fume Suction

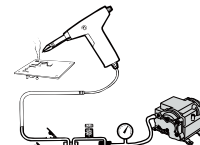

### External Dimensions (Unit: mm)

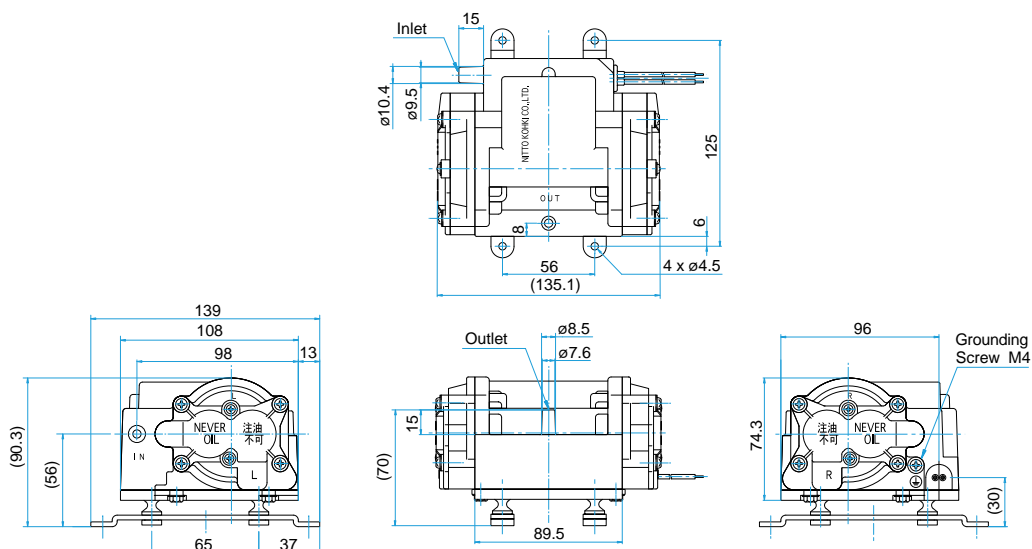

# Compressor

## Model VC0301B

120 V is made to order

### Blower Type

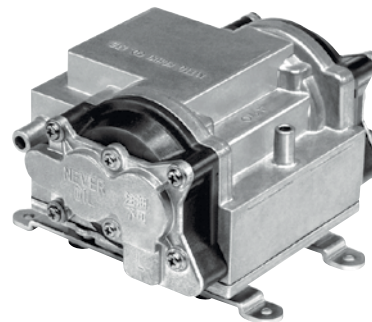

#### Airflow & Power Consumption

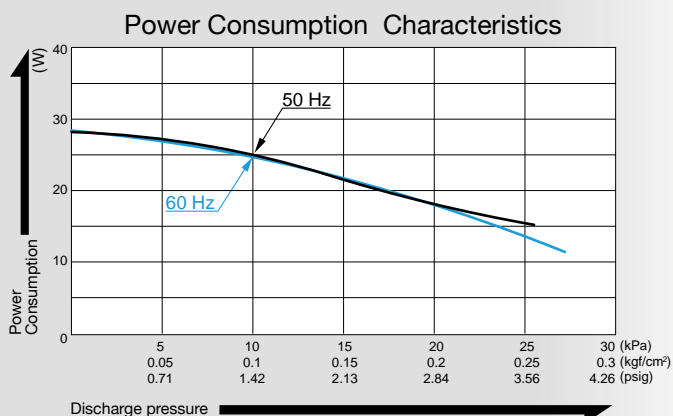
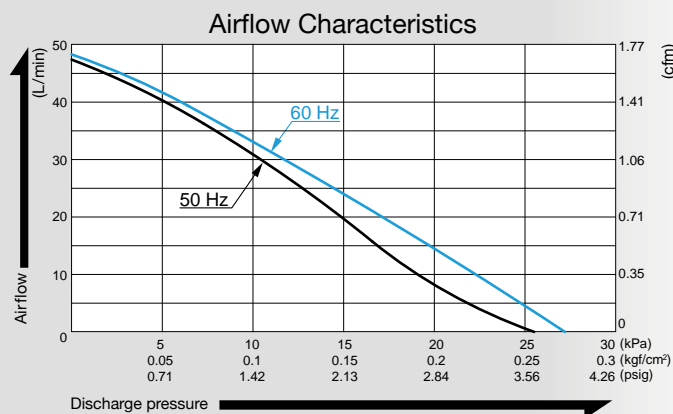

#### Specifications

Rated Pressure	10 kPa (0.1 kgf/cm <sup>2</sup> ) 0.1 bar 1.42 psig	
Rated Airflow	25 L/min 0.88 cfm	
Maximum Pressure	20 kPa (0.2 kgf/cm <sup>2</sup> ) 0.2 bar 2.84 psig	
Rated Voltage	120 V AC	230 V AC
Power Consumption	27 W	
Rated Frequency	60 Hz	50 Hz
Rated Performance	10,000 hours	
Working Pressure Range	0 to 20 kPa (0 to 0.2 kgf/cm <sup>2</sup> ) 0 to 0.2 bar 0 to 2.84 psig	
Outlet	8.5 mm O.D. hose barb	
Duty Cycle	Continuous	
Coil Insulation Class	B or its equivalent	
Mounting Dimensions	125 (L) x 56 (W) mm 4 - 59/64" (L) x 2 - 13/64" (W)	
Weight	1.7 kg 3.7 Lbs	
Leadwire Length	300 mm 11 - 13/16"	

#### Application Examples

Bedsore Prevention  
Mattress

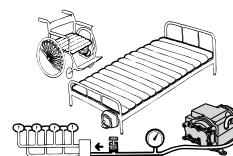

#### External Dimensions (Unit: mm)

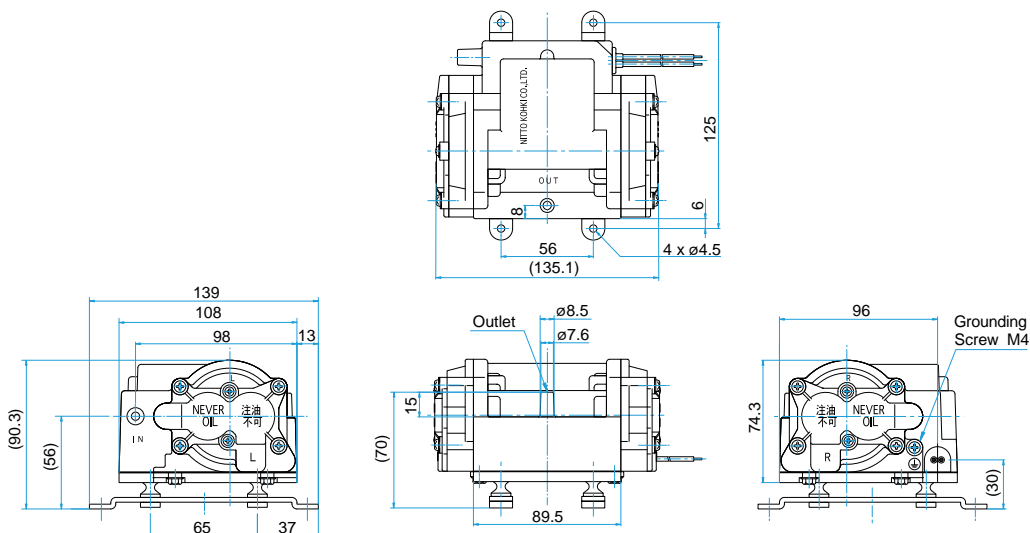

# DC Motor Driven

Piston Pump  
Diaphragm Pump

# PISTON PUMP DIAPHRAGM PUMP

DP series

Page

### Piston Pump

- DP0105-X1 — 61
- DP0105-Y1 — 62
- DPA0105-X1 — 63
- DPA0105-Y1 — 64
- DP0410-X1 — 65
- DP0410-Y1 — 66
- DP0410-X2 — 67
- DP0410-Y2 — 68
- DP0410T-Y1 — 69
- DP0410T-Y2 — 70

### Diaphragm Pump

- DP0125 — 71
- DP0140 — 72
- DP0102 — 73
- DP0102S — 74
- DP0102H-X1 — 75
- DP0102H-X2 — 76
- DP0110-X1 — 77
- DP0110-Y1 — 78
- DP0110-X3 — 79
- DP0110T-X1 — 80
- DP0110T-Y1 — 81
- DP0210TA-Y1 — 82

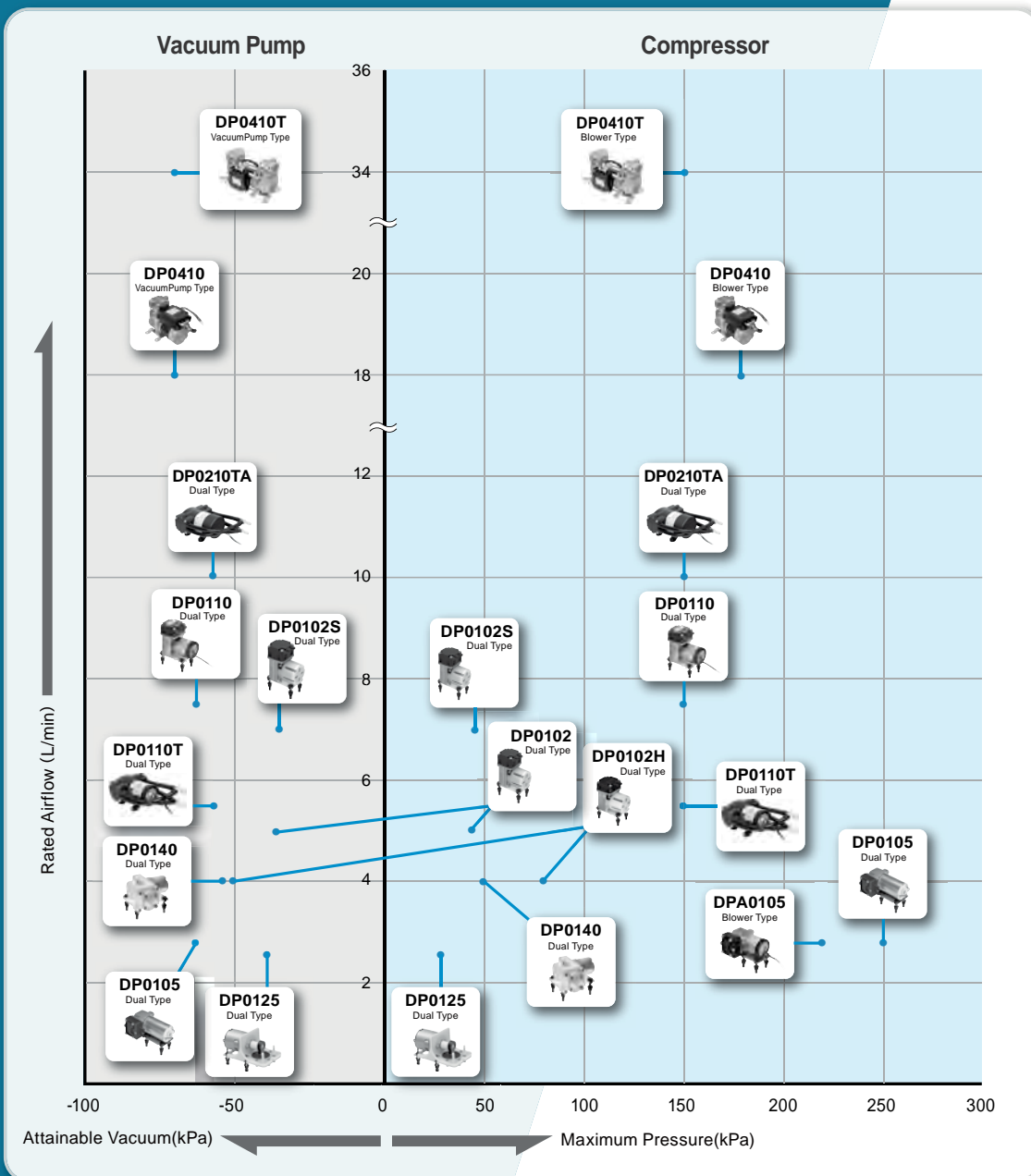

# Compressor and Vacuum Pump

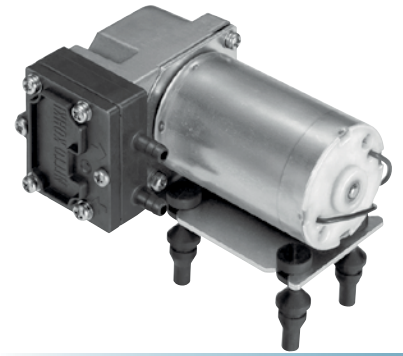

## Model DP0105-X1

Brush DC Motor 12 V DC



### Airflow & Power Consumption

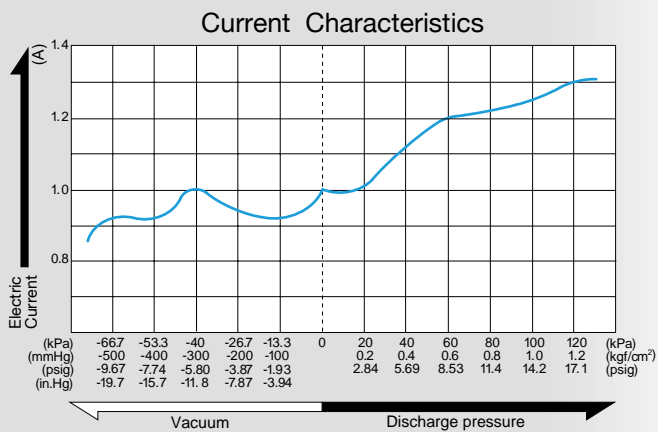
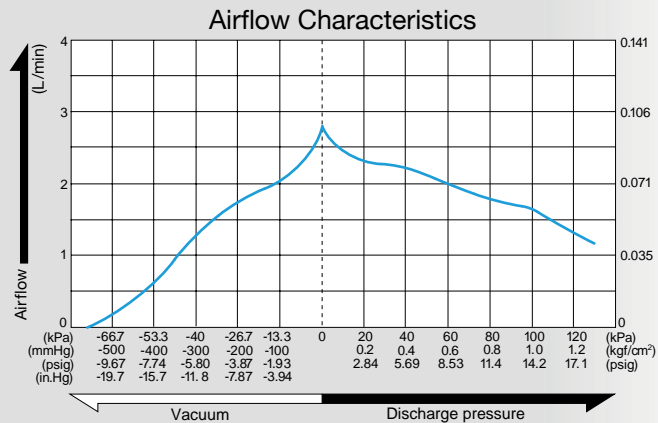

### Specifications

Attainable Vacuum	-66.7 kPa (-500 mmHg) -667 mbar -19.7 in.Hg
Free Air Displacement	2.8 L/min 0.099 cfm
Rated Voltage	12 V DC
Maximum Pressure	250 kPa (2.5 kgf/cm <sup>2</sup> ) 2.5 bar 35.6 psig
Maximum Current	1.9 A
Duty Cycle	30 minutes
Working Pressure Range	-66.7 to 100 kPa (-500 mmHg to 1 kgf/cm <sup>2</sup> ) -667 mbar to 1 bar -19.7 in.Hg to 14.2 psig
Rated Performance (MTTF)	2,000 hours
Inlet	5 mm O.D. straight barb
Outlet	5 mm O.D. straight barb
Coil Insulation Class	E or its equivalent
Mounting Dimensions	42 (L) x 24.5 (W) mm 1 - 21/32" (L) x 1 - 31/32" (W)
Weight	0.36 kg 0.79 Lbs
Leadwire Length	360 mm 14 - 11/64"

### Application Examples

#### Vending Machines

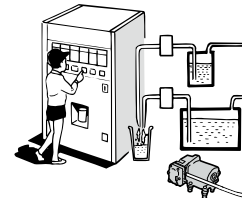

### External Dimensions (Unit: mm)

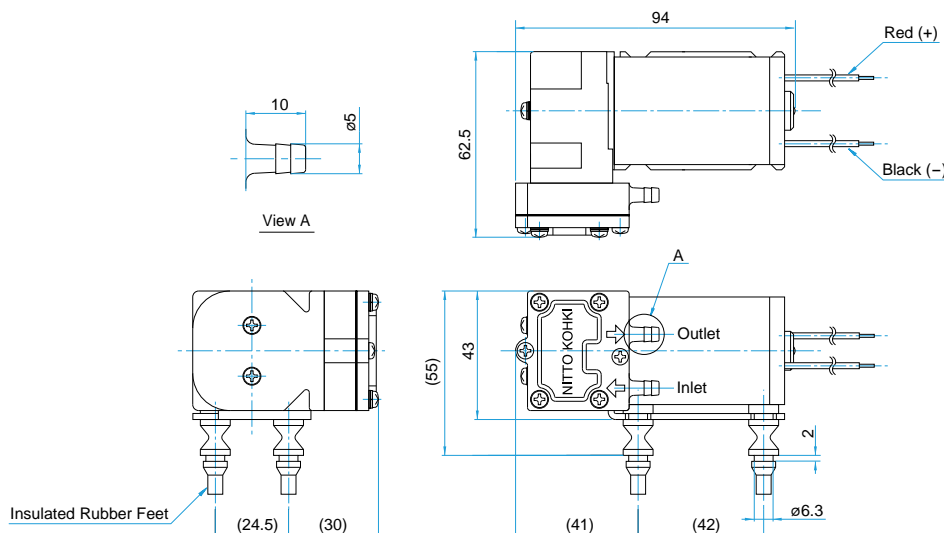

# Compressor and Vacuum Pump

## Model **DP0105-Y1**

Brush DC Motor 24 V DC

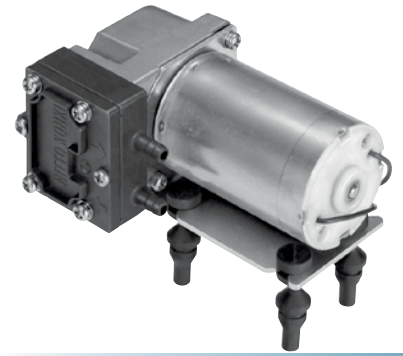

### Airflow & Power Consumption

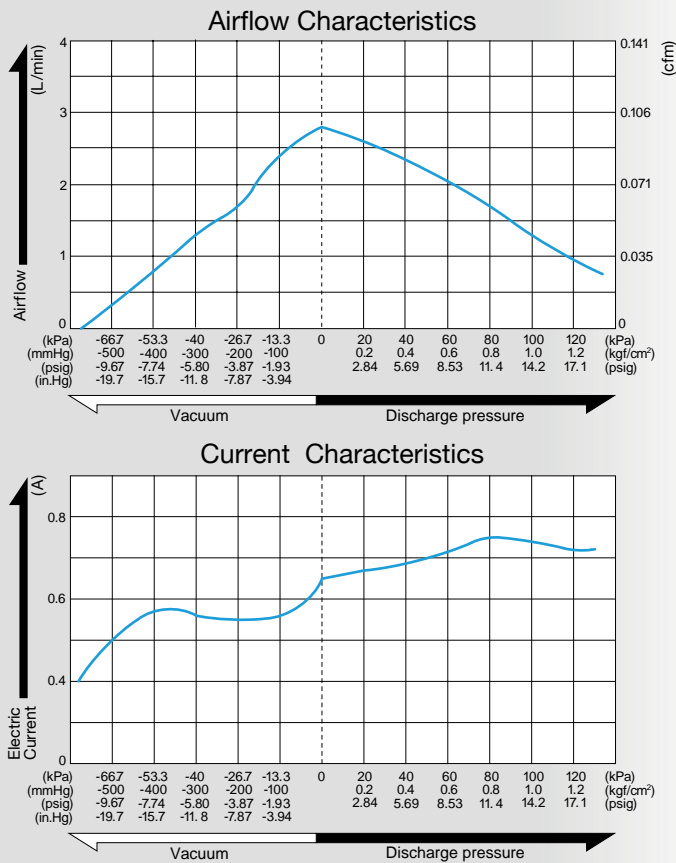

### Specifications

Attainable Vacuum	-66.7 kPa (-500 mmHg) -667 mbar -19.7 in.Hg
Free Air Displacement	2.8 L/min 0.099 cfm
Rated Voltage	24 V DC
Maximum Pressure	250 kPa (2.5 kgf/cm <sup>2</sup> ) 2.5 bar 35.6 psig
Maximum Current	0.95 A
Duty Cycle	30 minutes
Working Pressure Range	-66.7 to 100 kPa (-500 mmHg to 1 kgf/cm <sup>2</sup> ) -667 mbar to 1 bar -19.7 in.Hg to 14.2 psig
Rated Performance (MTTF)	2,000 hours
Inlet	5 mm O.D. straight barb
Outlet	5 mm O.D. straight barb
Coil Insulation Class	E or its equivalent
Mounting Dimensions	42 (L) x 24.5 (W) mm 1 - 21/32" (L) x 1 - 31/32" (W)
Weight	0.36 kg 0.79 Lbs
Leadwire Length	360 mm 14 - 11/64"

### Application Examples

#### Vending Machines

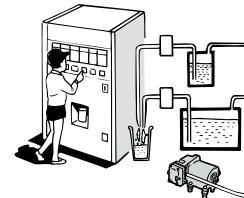

### External Dimensions (Unit: mm)

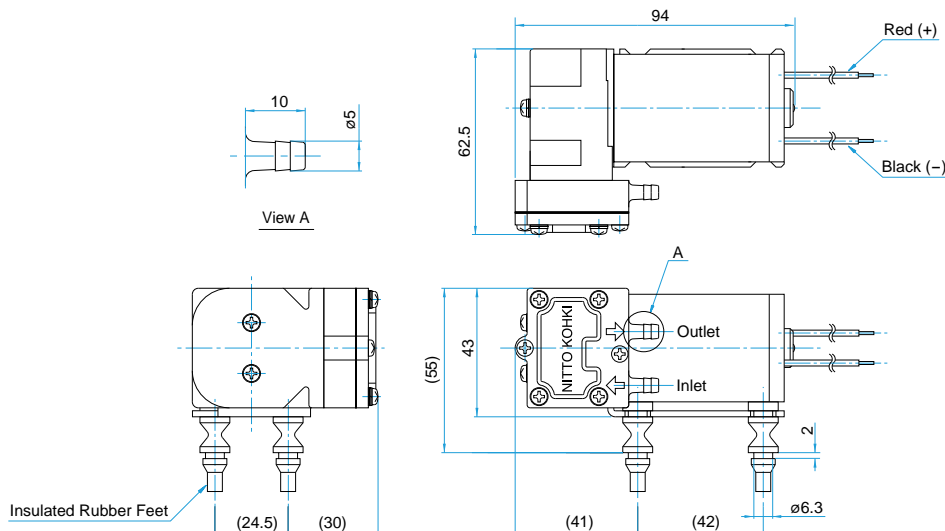

# Compressor

## Model **DPA0105-X1**



Brushless DC Motor **12 V DC**



### Airflow & Power Consumption

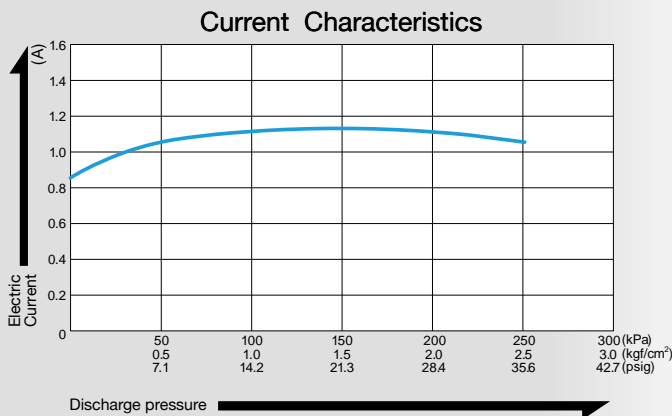
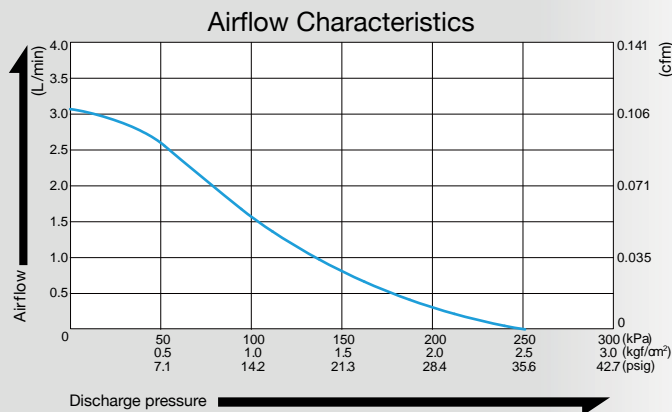

### Specifications

Free Air Displacement	2.8 L/min 0.099 cfm
Rated Voltage	12 V DC
Maximum Pressure	220 kPa (2.2 kgf/cm <sup>2</sup> ) 2.2 bar 31.3 psig
Maximum Current	1.4 A
Duty Cycle	Continuous
Working Pressure Range	0 to 100 kPa (0 to 1 kgf/cm <sup>2</sup> ) 0 to 1 bar 0 to 14.2 psig
Rated Performance (MTTF)	5,000 hours
Inlet	5 mm O.D. straight barb
Outlet	5 mm O.D. straight barb
Coil Insulation Class	A or its equivalent
Mounting Dimensions	32 (L) x 27.5 (W) mm 1 - 9/32" (L) x 1 - 5/64" (W)
Weight	0.3 kg 0.66 Lbs
Leadwire Length	360 mm 14 - 11/64"

### Application Examples

#### Vending Machines

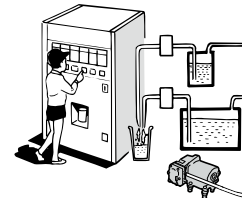

### External Dimensions (Unit: mm)

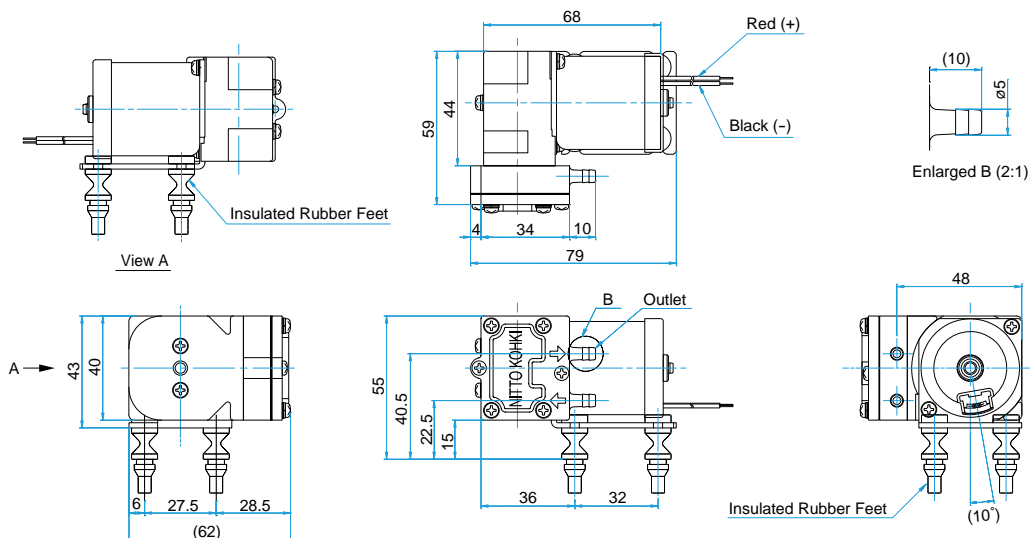



# Compressor

## Model **DPA0105-Y1**



**Brushless DC Motor 24 V DC**

### Airflow & Power Consumption

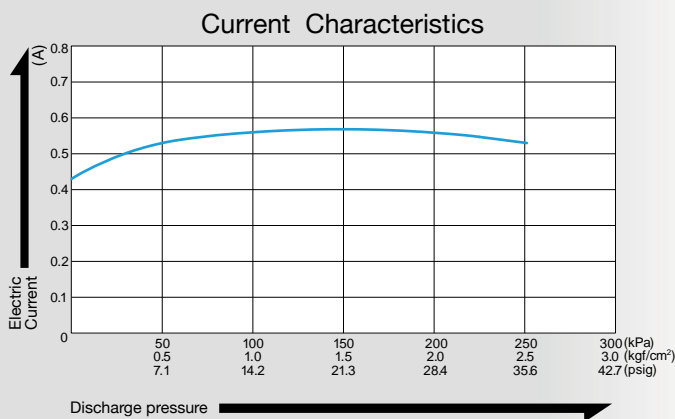
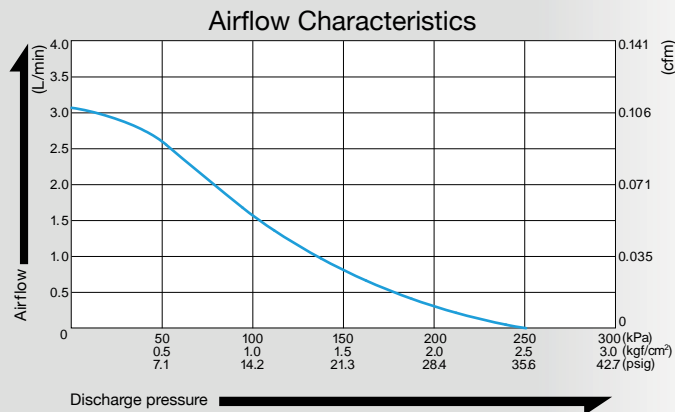

### Specifications

Free Air Displacement	2.8 L/min 0.099 cfm
Rated Voltage	24 V DC
Maximum Pressure	220 kPa (2.2 kgf/cm <sup>2</sup> ) 2.2 bar 31.3 psig
Maximum Current	0.7 A
Duty Cycle	Continuous
Working Pressure Range	0 to 100 kPa (0 to 1 kgf/cm <sup>2</sup> ) 0 to 1 bar 0 to 14.2 psig
Rated Performance (MTTF)	5,000 hours
Inlet	5 mm O.D. straight barb
Outlet	5 mm O.D. straight barb
Coil Insulation Class	A or its equivalent
Mounting Dimensions	32 (L) x 27.5 (W) mm 1 - 9/32" (L) x 1 - 5/64" (W)
Weight	0.3 kg 0.66 Lbs
Leadwire Length	360 mm 14 - 11/64"

### Application Examples

#### Vending Machines

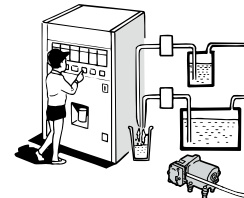

### External Dimensions (Unit: mm)

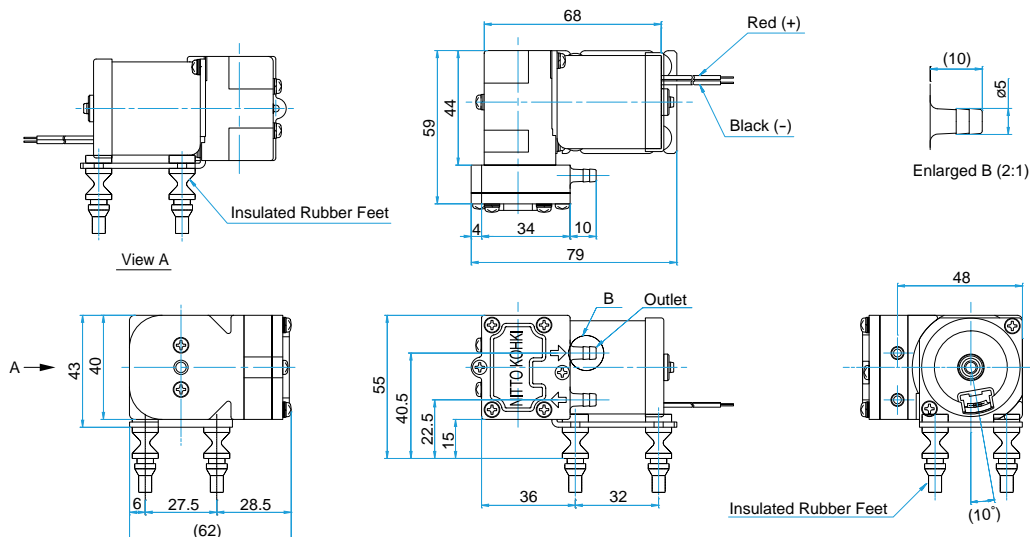

# Vacuum Pump

## Model **DP0410-X1**

Brushless DC Motor 12 V DC



### Airflow & Power Consumption

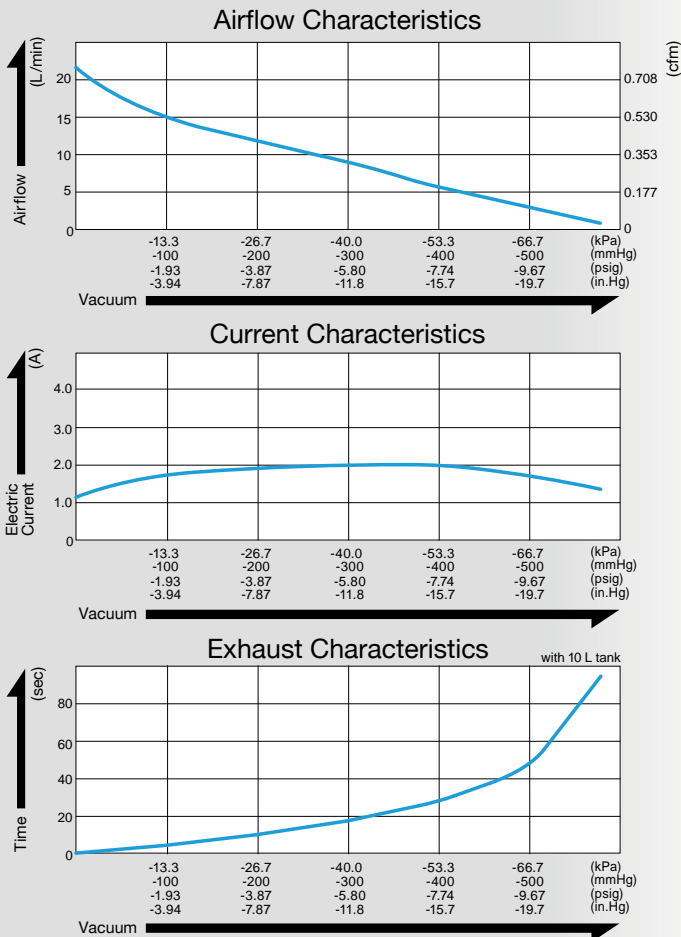

### Specifications

Attainable Vacuum	-77.3 kPa (-580 mmHg) -773 mbar -22.8 in.Hg
Free Air Displacement	18 L/min 0.64 cfm
Rated Voltage	12 V DC
Maximum Current	2.5 A or less
Duty Cycle	Continuous
Rated Performance (MTTF)	10,000 hours
Inlet	Rc1/8
Outlet	Rc1/8
Coil Insulation Class	E or its equivalent
Mounting Dimensions	70 (L) x 45 (W) mm 2 - 3/4" (L) x 1 - 49/64" (W)
Weight	1.1 kg 2.4 Lbs
Leadwire Length	285 mm 11 - 7/32"

### Application Examples

#### Air Cylinder/Chuck Driver

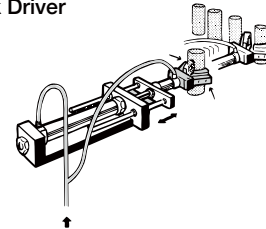

### External Dimensions (Unit: mm)

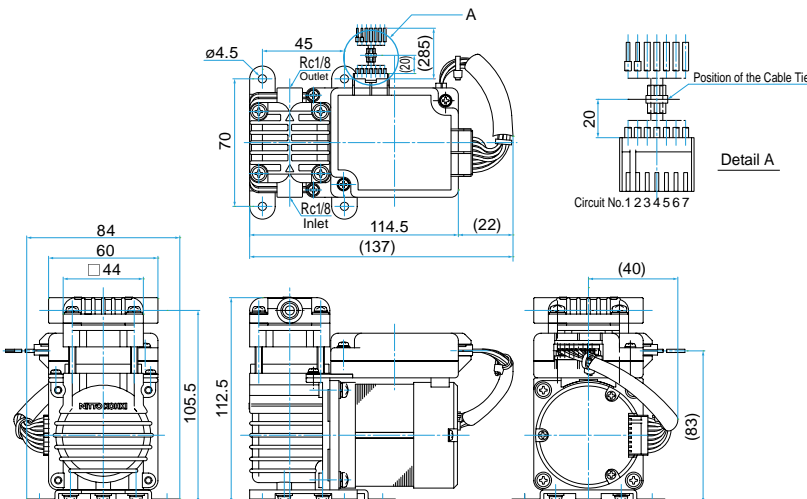

### Connection Table

Circuit No.	Power Source		Control Signal				
	1	2	3	4	5	6	7
Cord Color	Red	Black	Brown	Orange	Yellow	Green	Gray
Function	V+	V-	DRIVE/FREE	PULSE	ALARM	SPEED	SGND
Option	Function Off	ON	OFF				
	Function On	ON	ON				
Cord Size	AWG20		AWG22				
Line Type	UL1007						

\*Control function is "OFF" by default.

- Be sure to secure the lead wires with a cable tie. (See the detail A.) If they are not secured, poor contact of the connector may occur and result in failure.
- For the details of wiring, please see the user's instructions.

# Vacuum Pump



## Model DP0410-Y1

Brushless DC Motor 24 V DC



### Airflow & Power Consumption

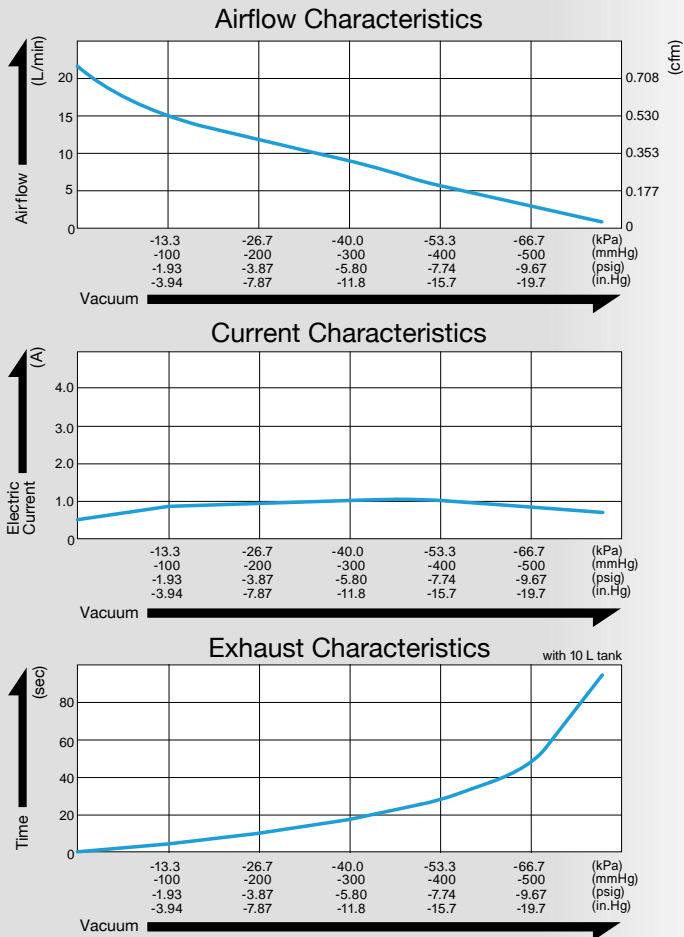

### Specifications

Attainable Vacuum	-77.3 kPa (-580 mmHg) -773 mbar -22.8 in.Hg
Free Air Displacement	18 L/min 0.64 cfm
Rated Voltage	24 V DC
Maximum Current	1.5 A or less
Duty Cycle	Continuous
Rated Performance (MTTF)	10,000 hours
Inlet	Rc1/8
Outlet	Rc1/8
Coil Insulation Class	E or its equivalent
Mounting Dimensions	70 (L) x 45 (W) mm 2 - 3/4" (L) x 1 - 49/64" (W)
Weight	1.1 kg 2.43 Lbs
Leadwire Length	285 mm 11 - 7/32"

### Application Examples

#### Air Cylinder/Chuck Driver

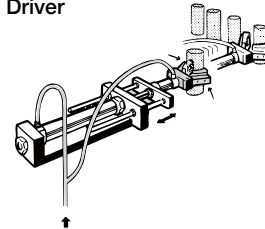

### External Dimensions (Unit: mm)

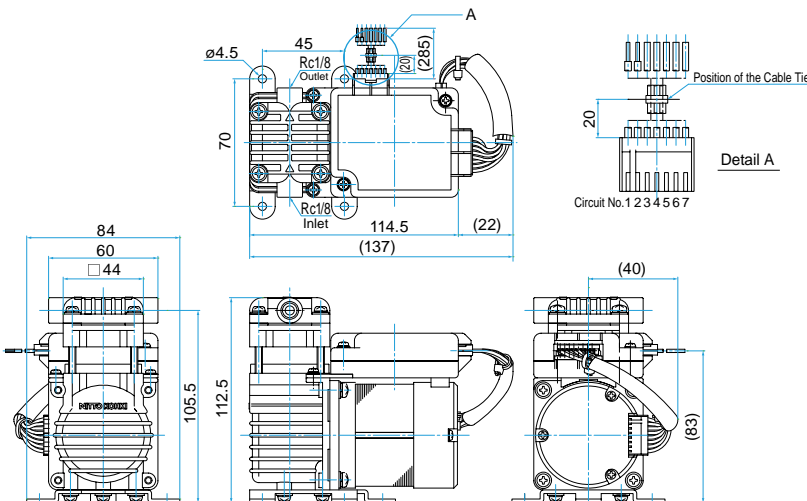

### Connection Table

Circuit No.	Power Source		Control Signal				
	1	2	3	4	5	6	7
Cord Color	Red	Black	Brown	Orange	Yellow	Green	Gray
Function	V+	V-	DRIVE/FREE	PULSE	ALARM	SPEED	SGND
Option	Function Off	ON	OFF				
	Function On	ON	ON				
Cord Size	AWG20		AWG22				
Line Type	UL1007						

\*Control function is "OFF" by default.

- Be sure to secure the lead wires with a cable tie. (See the detail A.) If they are not secured, poor contact of the connector may occur and result in failure.
- For the details of wiring, please see the user's instructions.

# Compressor

## Model **DP0410-X2**



**Brushless DC Motor 12 V DC**



### Airflow & Power Consumption

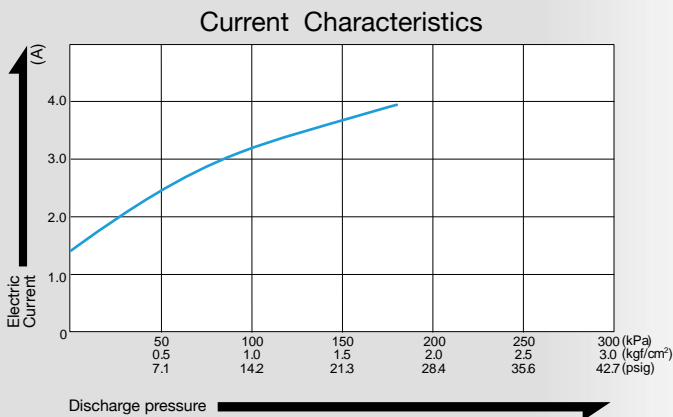
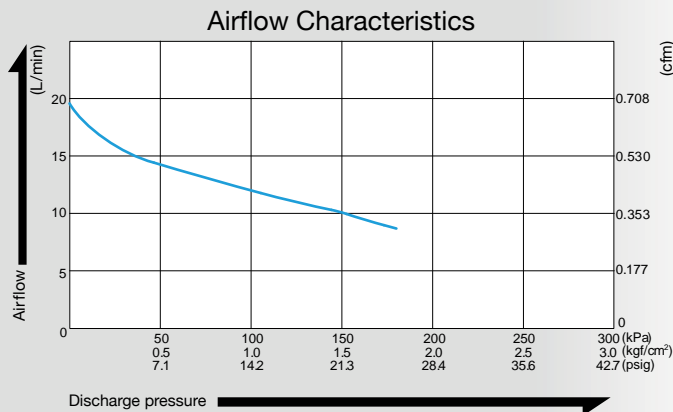

### Specifications

Free Air Displacement	18 L/min 0.64 cfm
Rated Voltage	12 V DC
Maximum Pressure	180 kPa (1.8 kgf/cm <sup>2</sup> ) 1.8 bar 25.6 psig
Maximum Current	5.0 A
Duty Cycle	Continuous
Working Pressure Range	0 to 180 kPa (0 to 1.8 kgf/cm <sup>2</sup> ) 0 to 1.8 bar 0 to 25.6 psig
Rated Performance (MTTF)	10,000 hours
Inlet	ISO RC 1/8
Outlet	ISO RC 1/8
Coil Insulation Class	E or its equivalent
Mounting Dimensions	70 (L) x 45 (W) mm 2 - 3/4" (L) x 1 - 49/64" (W)
Weight	1.1 kg 2.4 Lbs
Leadwire Length	285 mm 11 - 7/32"

### Application Examples

#### Air Cylinder/Chuck Driver

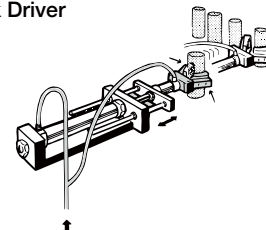

### External Dimensions (Unit: mm)

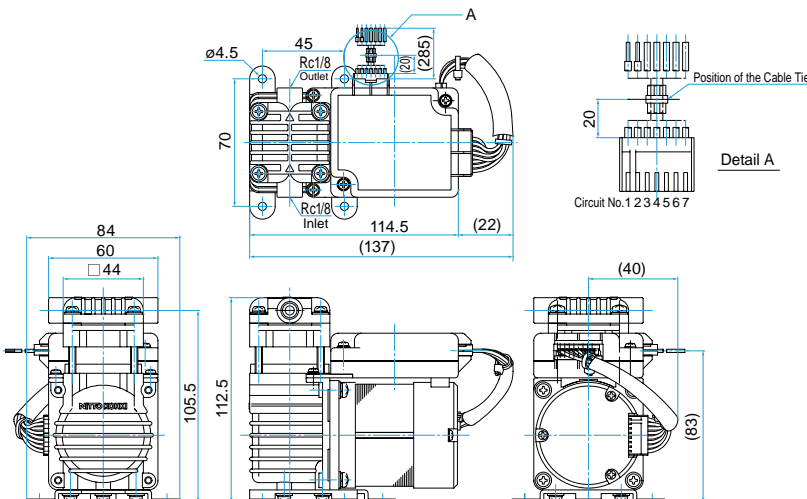

### Connection Table

Circuit No.	Power Source		Control Signal				
	1	2	3	4	5	6	7
Cord Color	Red	Black	Brown	Orange	Yellow	Green	Gray
Function	V+	V-	DRIVE/FREE	PULSE	ALARM	SPEED	SGND
Option	Function Off	ON	OFF				
	Function On	ON	ON				
Cord Size	AWG20		AWG22				
Line Type	UL1007						

\*Control function is "OFF" by default.

- Be sure to secure the lead wires with a cable tie. (See the detail A.) If they are not secured, poor contact of the connector may occur and result in failure.
- For the details of wiring, please see the user's instructions.

# Compressor

## Model **DP0410-Y2**

Brushless DC Motor 24 V DC



### Airflow & Power Consumption

Airflow Characteristics

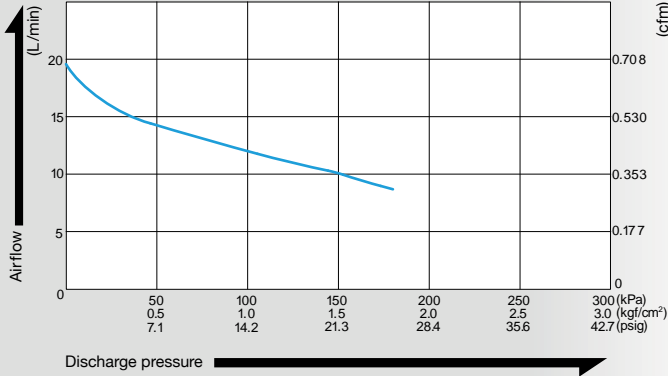

Current Characteristics

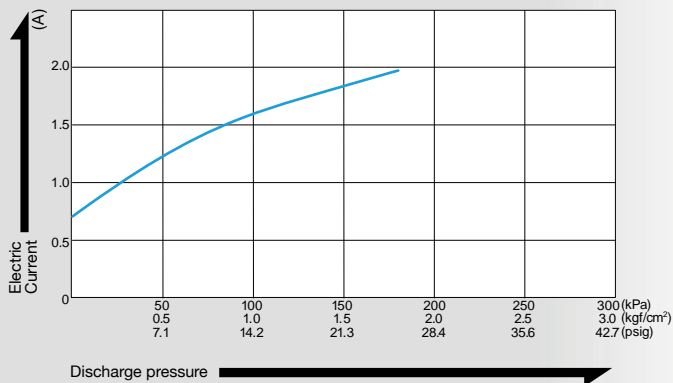

### Specifications

Free Air Displacement	18 L/min 0.64 cfm
Rated Voltage	24 V DC
Maximum Pressure	180 kPa (1.8 kgf/cm <sup>2</sup> ) 1.8 bar 25.6 psig
Maximum Current	2.7 A
Duty Cycle	Continuous
Working Pressure Range	0 to 180 kPa (0 to 1.8 kgf/cm <sup>2</sup> ) 0 to 1.8 bar 0 to 25.6 psig
Rated Performance (MTTF)	10,000 hours
Inlet	ISO RC 1/8
Outlet	ISO RC 1/8
Coil Insulation Class	E or its equivalent
Mounting Dimensions	70 (L) x 45 (W) mm 2 - 3/4" (L) x 1 - 49/64" (W)
Weight	1.1 kg 2.4 Lbs
Leadwire Length	285 mm 11 - 7/32"

### Application Examples

#### Air Cylinder/Chuck Driver

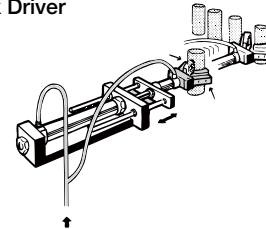

### External Dimensions (Unit: mm)

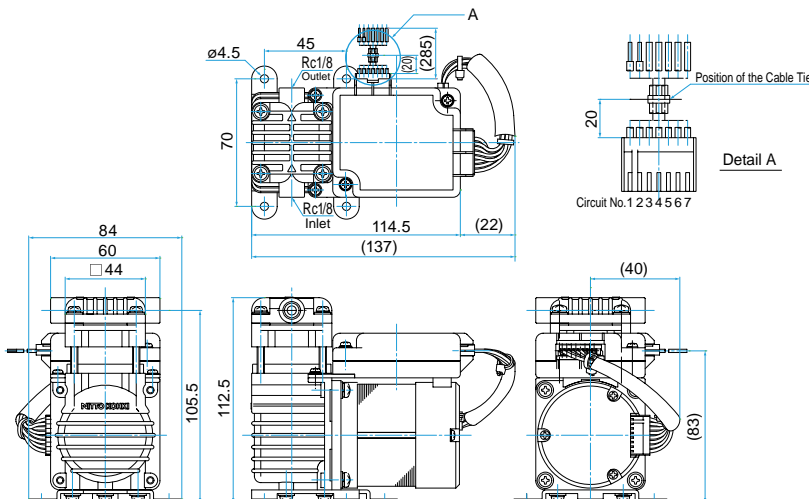

### Connection Table

Circuit No.	Power Source		Control Signal				
	1	2	3	4	5	6	7
Cord Color	Red	Black	Brown	Orange	Yellow	Green	Gray
Function	V+	V-	DRIVE/FREE	PULSE	ALARM	SPEED	SGND
Option	Function Off	ON	OFF				
	Function On	ON	ON				
Cord Size	AWG20		AWG22				
Line Type	UL1007						

\*Control function is "OFF" by default.

- Be sure to secure the lead wires with a cable tie. (See the detail A.) If they are not secured, poor contact of the connector may occur and result in failure.
- For the details of wiring, please see the user's instructions.

# Vacuum Pump



## Model DP0410T-Y1

Brushless DC Motor 24 V DC



### Airflow & Power Consumption

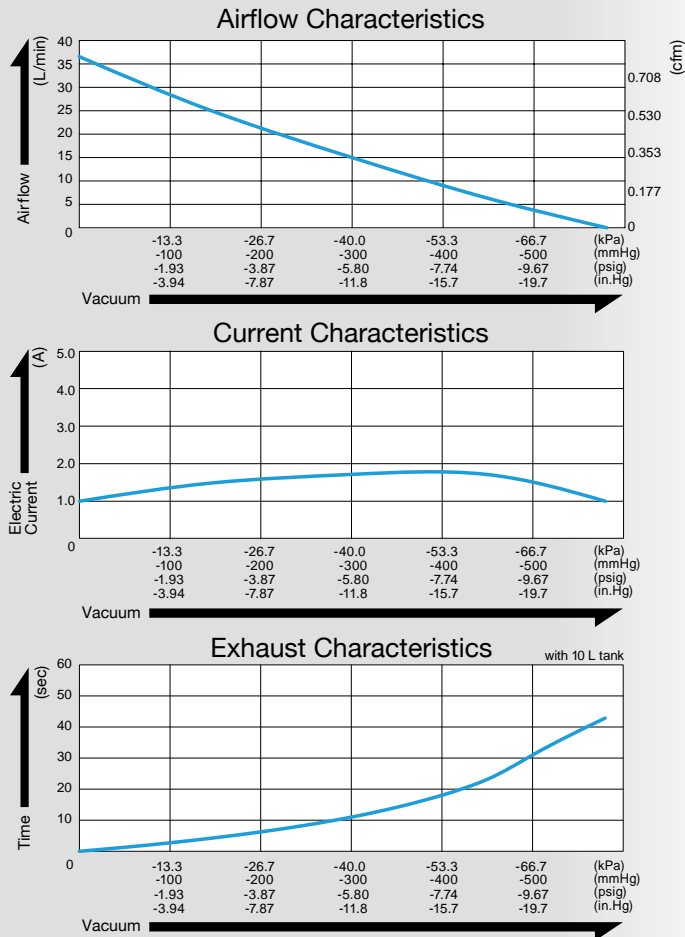

### Specifications

Attainable Vacuum	-77.3 kPa (-580 mmHg) -773 mbar -22.8 in.Hg
Free Air Displacement	34 L/min 1.2 cfm
Rated Voltage	24 V DC
Maximum Current	2.5 A
Duty Cycle	Continuous
Rated Performance (MTTF)	5,000 hours
Inlet	Rc1/8
Outlet	Rc1/8
Coil Insulation Class	E or its equivalent (For DC motor)
Mounting Dimensions	166 (L) x 84 (W) mm 6 - 17/32" (L) x 3 - 5/16" (W)
Weight	1.6 kg 3.5 Lbs
Leadwire Length	285 mm 11 - 7/32"

### Application Examples

#### Air Cylinder/Chuck Driver

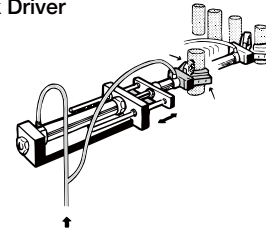

### External Dimensions (Unit: mm)

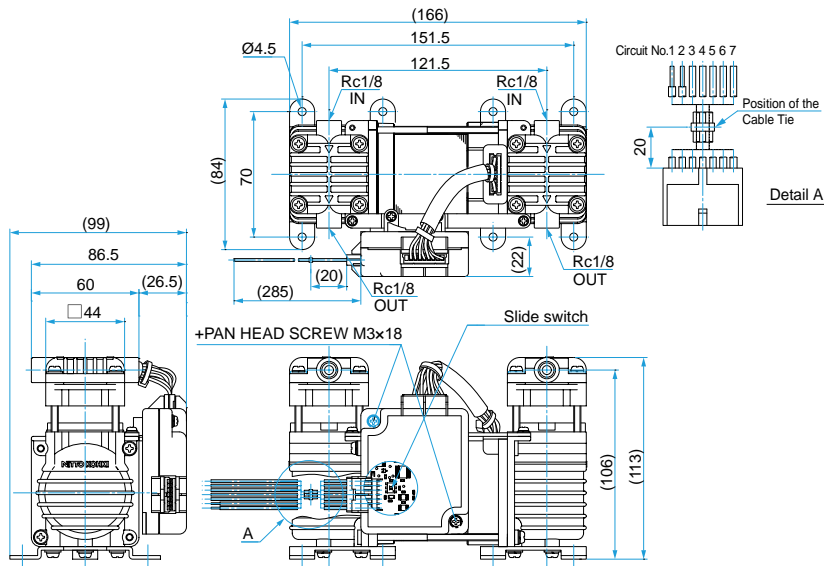

### Connection Table

Circuit No.	Power Source		Control Signal				
	1	2	3	4	5	6	7
Cord Color	Red	Black	Brown	Orange	Yellow	Green	Gray
Function	V+	V-	DRIVE/FREE	PULSE	ALARM	SPEED	SGND
Option	Function Off	ON			OFF		
	Function On	ON			ON		
Cord Size	AWG20			AWG22			
Line Type	UL1007						

\*Control function is "OFF" by default.

- Be sure to secure the lead wires with a cable tie. (See the detail A.) If they are not secured, poor contact of the connector may occur and result in failure.
- For the details of wiring, please see the user's instructions.

# Compressor

## Model DPO410T-Y2



Brushless DC Motor 24 V DC



### Airflow & Power Consumption

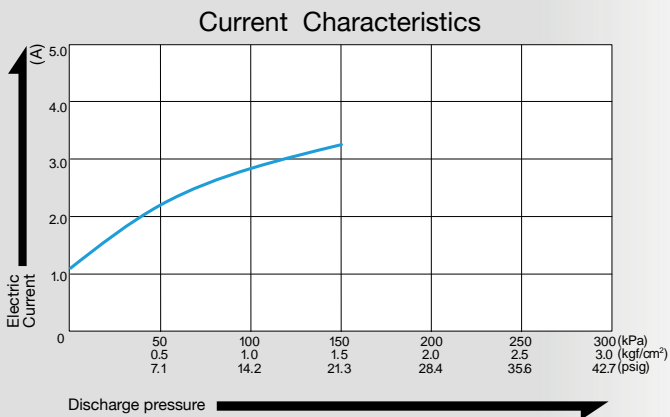
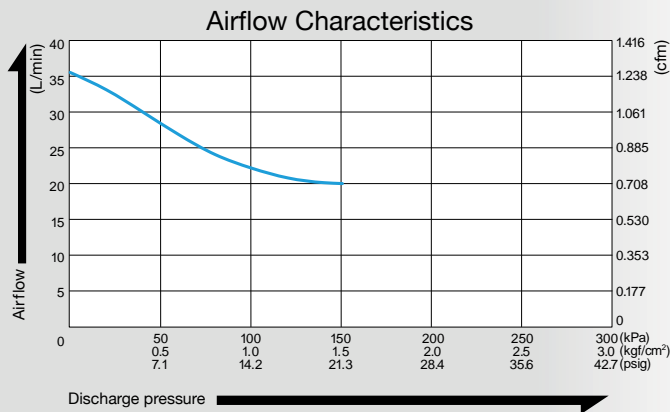

### Specifications

Free Air Displacement	34 L/min 1.2 cfm
Rated Voltage	24 V DC
Maximum Pressure	150 kPa (1.5 kgf/cm <sup>2</sup> ) 1.5 bar 21.3 psig
Maximum Current	4.0 A
Duty Cycle	Continuous
Working Pressure Range	0 to 150 kPa (0 to 1.5 kgf/cm <sup>2</sup> ) 0 to 1.5 bar 0 to 21.3 psig
Rated Performance (MTTF)	5,000 hours
Inlet	RC 1/8
Outlet	RC 1/8
Coil Insulation Class	E or its equivalent (For DC motor)
Mounting Dimensions	166 (L) x 84 (W) mm 6 - 17/32" (L) x 3 - 5/16" (W)
Weight	1.6 kg 3.5 Lbs
Leadwire Length	285 mm 11 - 7/32"

### Application Examples

#### Air Cylinder/Chuck Driver

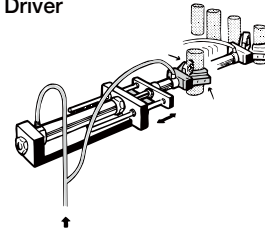

### External Dimensions (Unit: mm)

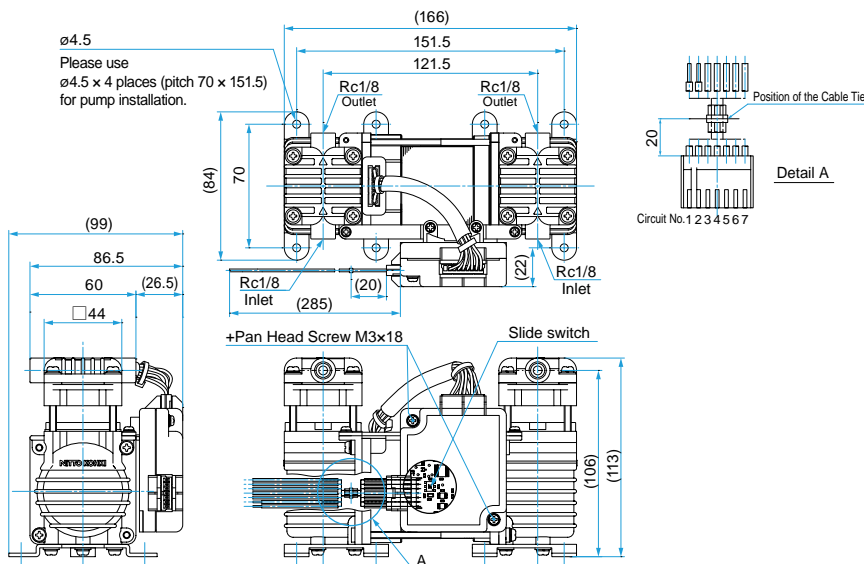

### Connection Table

Circuit No.	Power Source			Control Signal			
	1	2	3	4	5	6	7
Cord Color	Red	Black	Brown	Orange	Yellow	Green	Gray
Function	V+	V-	DRIVE, FREE	PULSE	ALARM	SPEED	SGND
Option	Function Off	ON			OFF		
	Function On	ON			ON		
Cord Size	AWG20			AWG22			
Line Type	UL1007						

\*Control function is "OFF" by default.

- Be sure to secure the lead wires with a cable tie. (See the detail A.) If they are not secured, poor contact of the connector may occur and result in failure.
- For the details of wiring, please see the user's instructions.

# Compressor and Vacuum Pump

## Model **DP0125**



Brush DC Motor 12 V DC

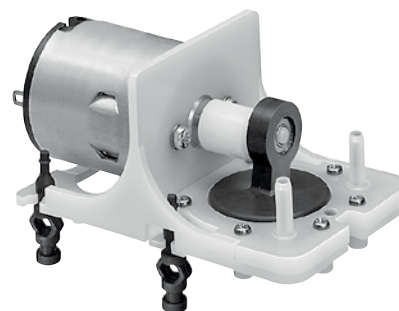

### Airflow & Power Consumption

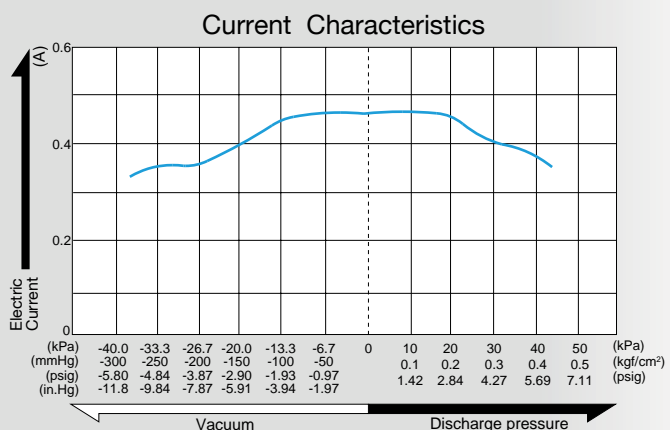
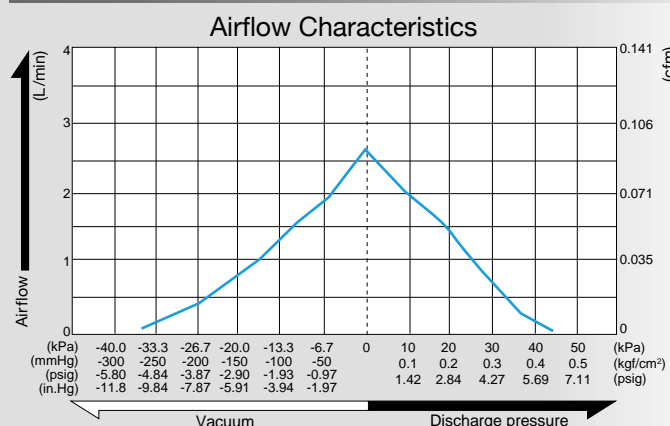

### Specifications

Attainable Vacuum	-33.3 kPa (-250 mmHg) -333 mbar - 9.84 in.Hg
Free Air Displacement	2.5 L/min 0.088 cfm
Rated Voltage	12 V DC
Maximum Pressure	30 kPa (0.3 kgf/cm <sup>2</sup> ) 0.3 bar 4.27 psig
Maximum Current	0.5 A
Duty Cycle	Continuous
Rated Performance (MTTF)	400 hours
Inlet	3 mm O.D. straight barb
Outlet	3 mm O.D. straight barb
Coil Insulation Class	E or its equivalent
Mounting Dimensions	32 (L) x 32.5 (W) mm 1 - 17/64" (L) x 1 - 9/32" (W)
Weight	0.08 kg 0.18 Lbs

### Application Examples

Vacuum Sucking Pen

Blood Pressure Tester

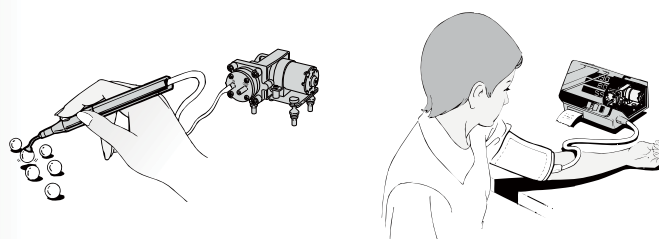

### External Dimensions (Unit: mm)

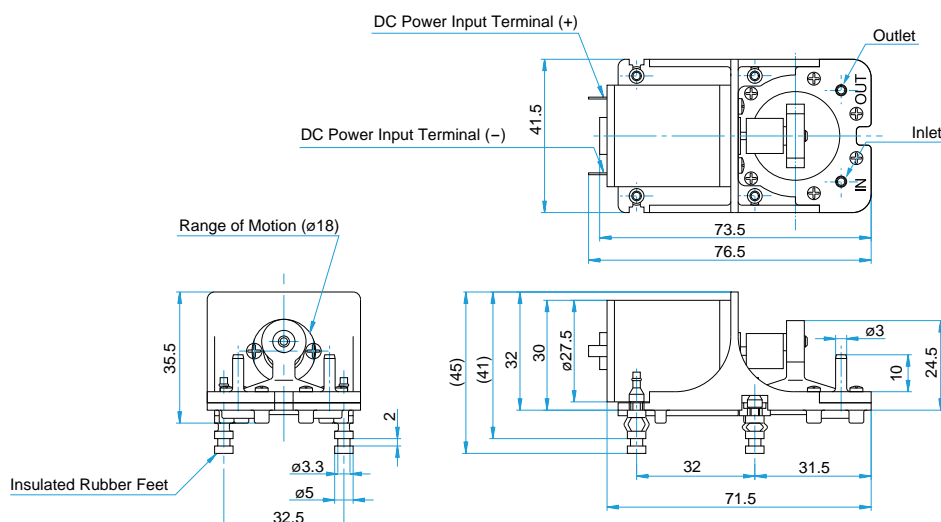



# Compressor and Vacuum Pump

## Model **DP0140**

Brush DC Motor 12 V DC



### Airflow & Power Consumption

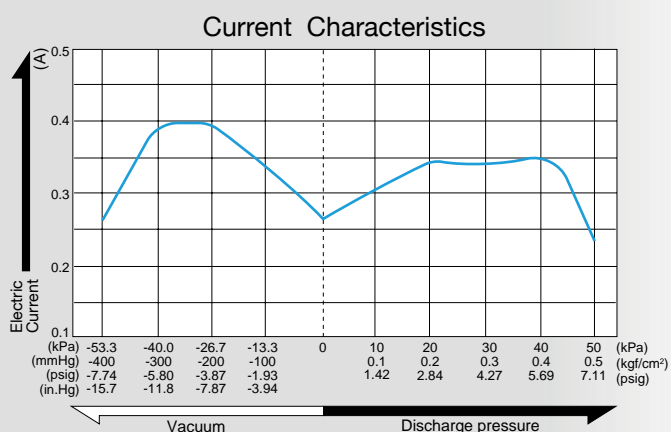
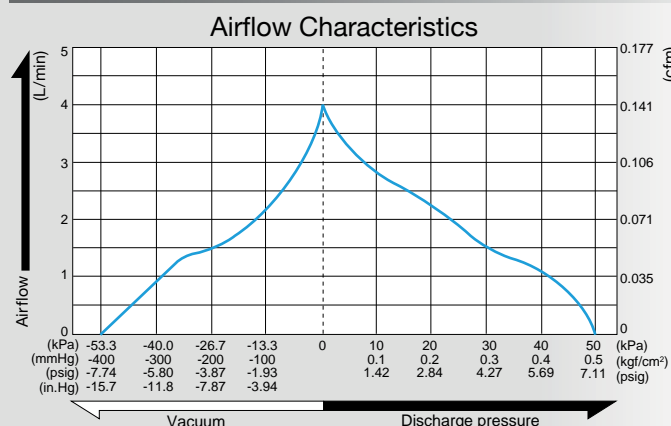

### Specifications

Attainable Vacuum	-53.3 kPa (-400 mmHg) -533 mbar -15.7 in.Hg
Free Air Displacement	4.0 L/min 0.141 cfm
Rated Voltage	12 V DC
Maximum Pressure	50 kPa (0.5 kgf/cm <sup>2</sup> ) 0.5 bar 7.11 psig
Maximum Current	0.5 A
Duty Cycle	Continuous
Rated Performance (MTTF)	800 hours
Inlet	5 mm O.D. straight barb
Outlet	5 mm O.D. straight barb
Coil Insulation Class	E or its equivalent
Mounting Dimensions	52 (L) x 36 (W) mm 2 - 3/64" (L) x 1 - 27/64" (W)
Weight	0.19 kg 0.42 Lbs

### Application Examples

Vacuum Sucking Pen

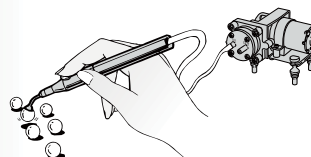

Blood Pressure Tester

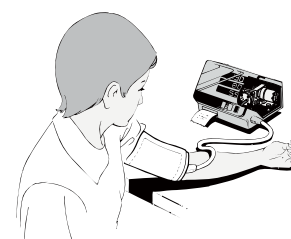

### External Dimensions (Unit: mm)

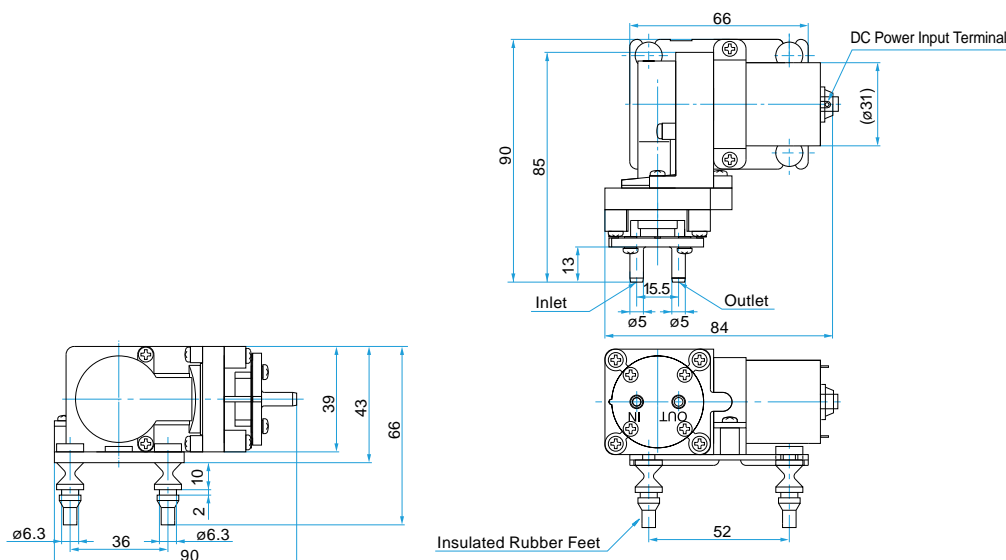

# Compressor and Vacuum Pump

## Model DP0102

Brushless DC Motor 12 V DC



### Airflow & Power Consumption

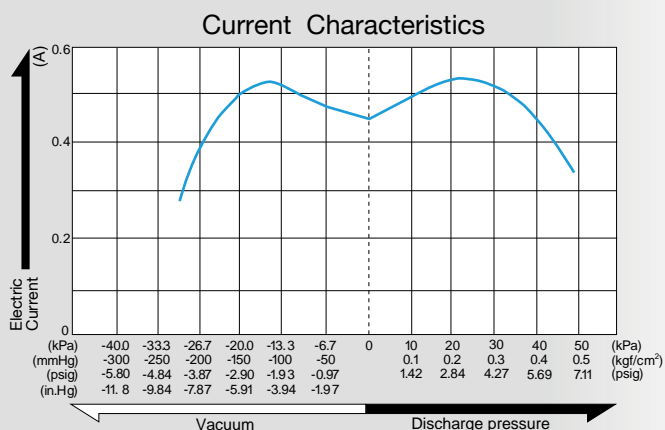
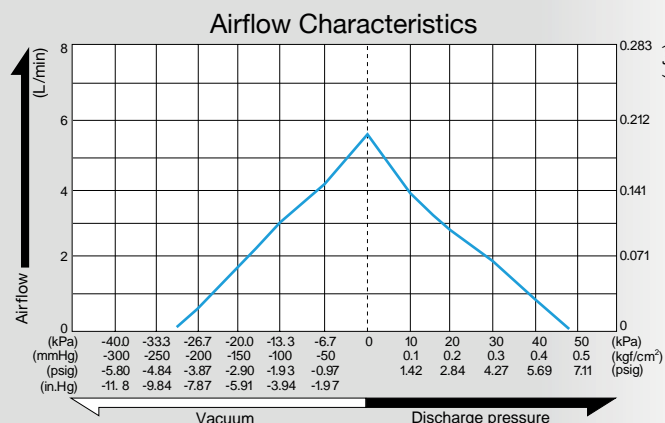

### Specifications

Attainable Vacuum	-26.7 kPa (-200 mmHg) -267 mbar -7.87 in.Hg
Free Air Displacement	5.0 L/min 0.177 cfm
Rated Voltage	12 V DC
Maximum Pressure	45 kPa (0.45 kgf/cm <sup>2</sup> ) 0.45 bar 6.4 psig
Maximum Current	0.7 A
Duty Cycle	Continuous
Working Pressure Range	-26.7 kPa to 45 kPa (-200 mmHg to 0.45 kgf/cm <sup>2</sup> ) -267 mbar to 0.45 bar -7.87 in.Hg to 6.4 psig
Rated Performance (MTTF)	10,000 hours
Inlet	6 mm O.D. straight barb
Outlet	6 mm O.D. straight barb
Coil Insulation Class	E or its equivalent
Mounting Dimensions	50 (L) x 30 (W) mm 1 - 31/32" (L) x 1 - 3/16" (W)
Weight	0.25 kg 0.55 Lbs
Leadwire Length	400 mm 15 - 3/4"

### Application Examples

#### Endoscopes



#### Removal of micromachining chips

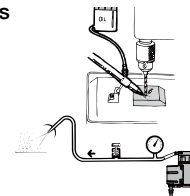

### External Dimensions (Unit: mm)

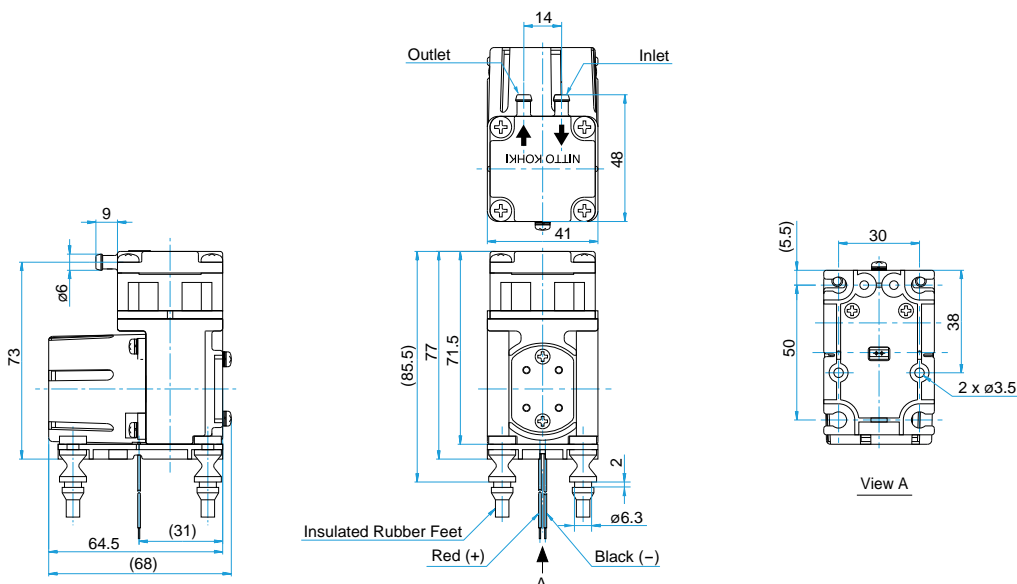

# Compressor and Vacuum Pump

## Model **DPO102S**



Brushless DC Motor 24 V DC



### Airflow & Power Consumption

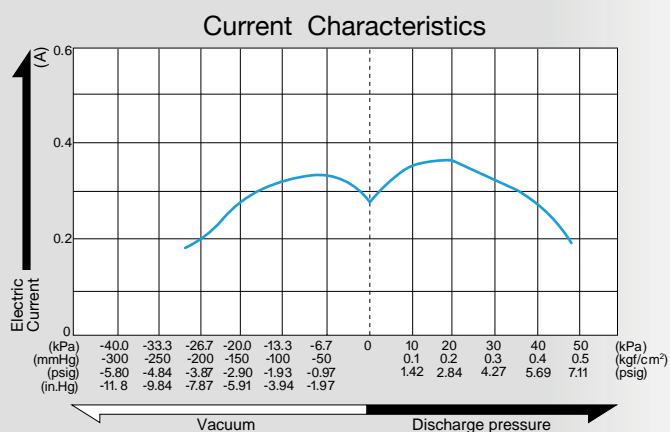
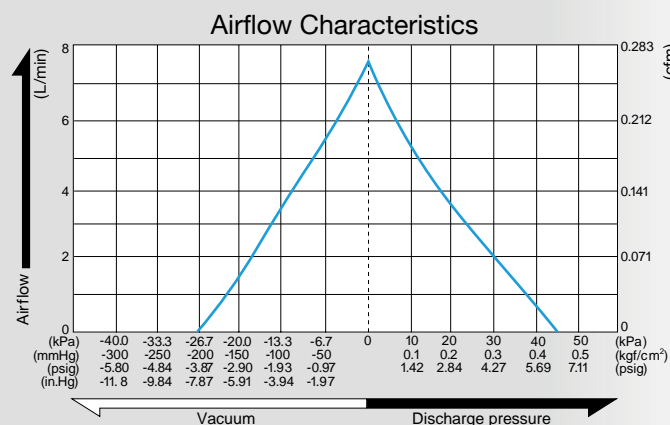

### Specifications

Attainable Vacuum	-26.7 kPa (-200 mmHg) -267 mbar -7.87 in.Hg
Free Air Displacement	7.0 L/min 0.247 cfm
Rated Voltage	24 V DC
Maximum Pressure	45 kPa (0.45 kgf/cm <sup>2</sup> ) 0.45 bar 6.4 psig
Maximum Current	0.5 A
Duty Cycle	Continuous
Working Pressure Range	-26.7 kPa to 45 kPa (-200 mmHg to 0.45 kgf/cm <sup>2</sup> ) -267 mbar to 0.45 bar -7.87 in.Hg to 6.4 psig
Rated Performance (MTTF)	10,000 hours
Inlet	6 mm O.D. straight barb
Outlet	6 mm O.D. straight barb
Coil Insulation Class	E or its equivalent
Mounting Dimensions	50 (L) x 30 (W) mm 1 - 31/32" (L) x 1 - 3/16" (W)
Weight	0.25 kg 0.55 Lbs
Leadwire Length	400 mm 15 - 3/4"

### Application Examples

#### Endoscopes



#### Removal of micromachining chips

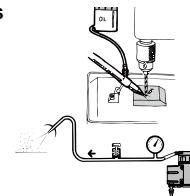

### External Dimensions (Unit: mm)

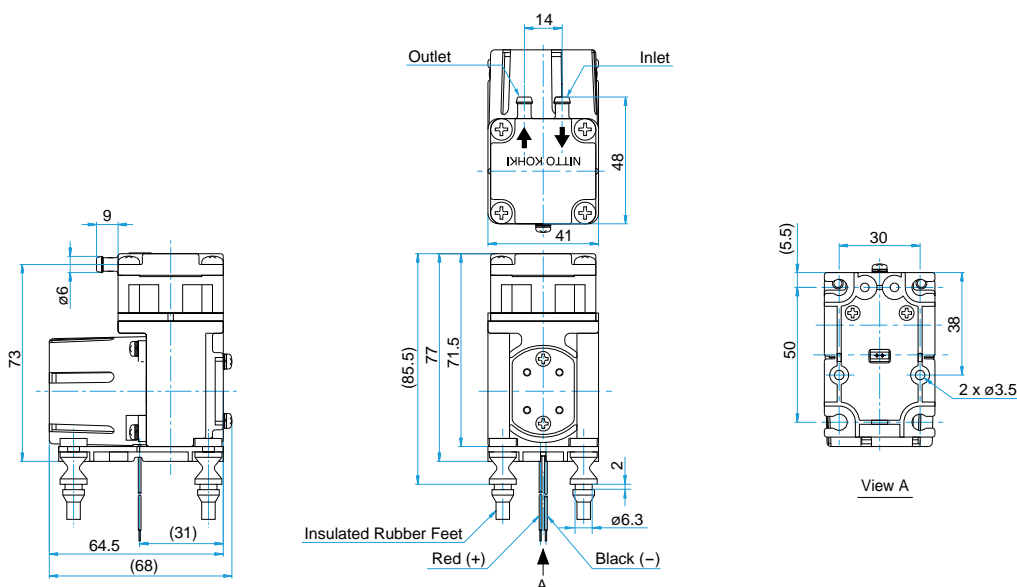

# Compressor and Vacuum Pump

## Model **DP0102H-X1**



Brushless DC Motor

12 V DC

### Airflow & Power Consumption

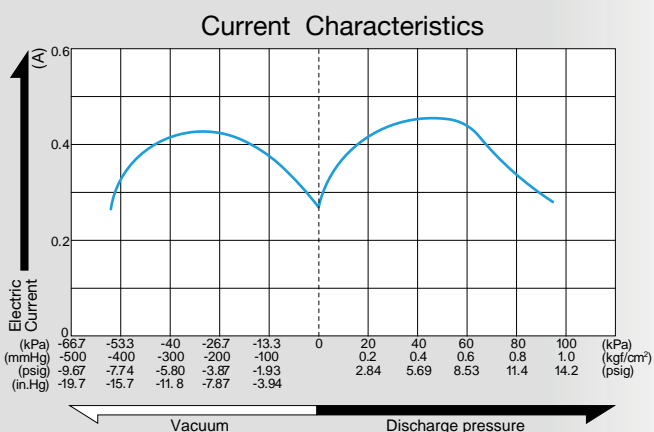
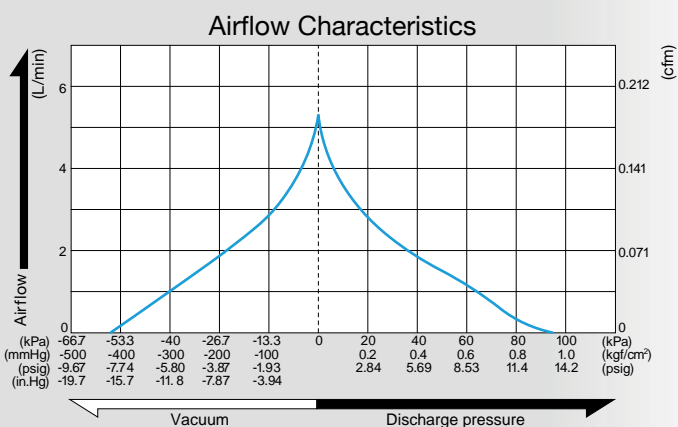

### Specifications

Attainable Vacuum	-50.7 kPa (-380 mmHg) -507 mbar -15 in.Hg
Free Air Displacement	4.0 L/min 0.141 cfm
Rated Voltage	12 V DC
Maximum Pressure	80 kPa (0.8 kgf/cm <sup>2</sup> ) 0.8 bar 11.4 psig
Maximum Current	0.7 A
Duty Cycle	Continuous
Working Pressure Range	-50.7 kPa to 80 kPa (-380 mmHg to 0.8 kgf/cm <sup>2</sup> ) -507 mbar to 0.8 bar -15 in.Hg to 11.4 psig
Rated Performance (MTTF)	8,000 hours
Inlet	6 mm O.D. straight barb
Outlet	6 mm O.D. straight barb
Coil Insulation Class	E or its equivalent
Mounting Dimensions	50 (L) x 30 (W) mm 1 - 31/32" (L) x 1 - 3/16" (W)
Weight	0.25 kg 0.55 Lbs
Leadwire Length	400 mm 15 - 3/4"

### Application Examples

Vacuum pick up and place devices for CD & DVD

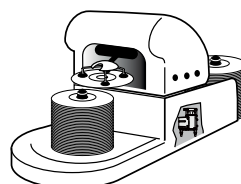

Removal of micromachining chips

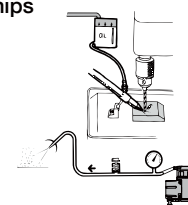

### External Dimensions (Unit: mm)

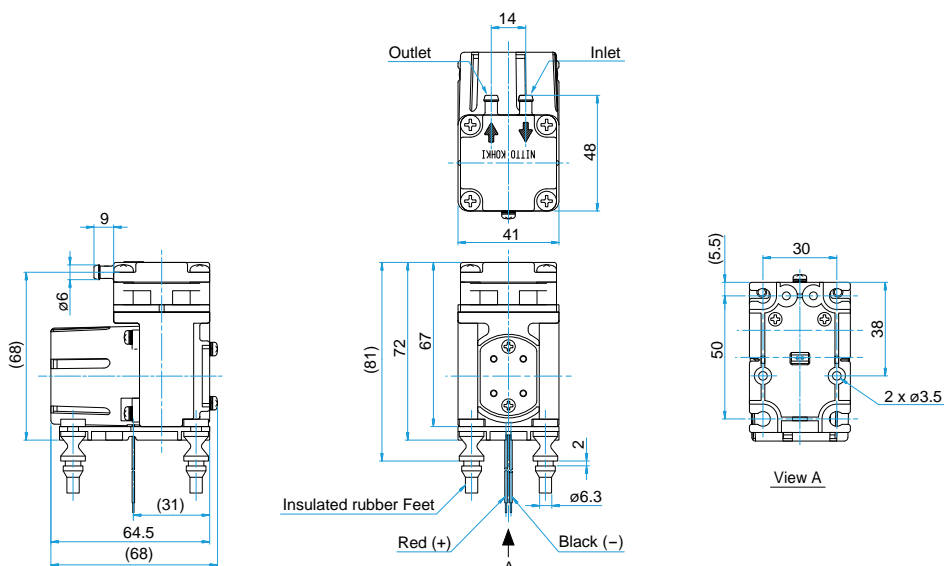

# Compressor

## Model **DP0102H-X2**

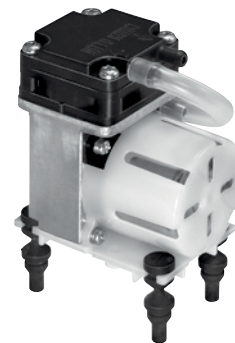

Brushless DC Motor **12 V DC**

### Airflow & Power Consumption

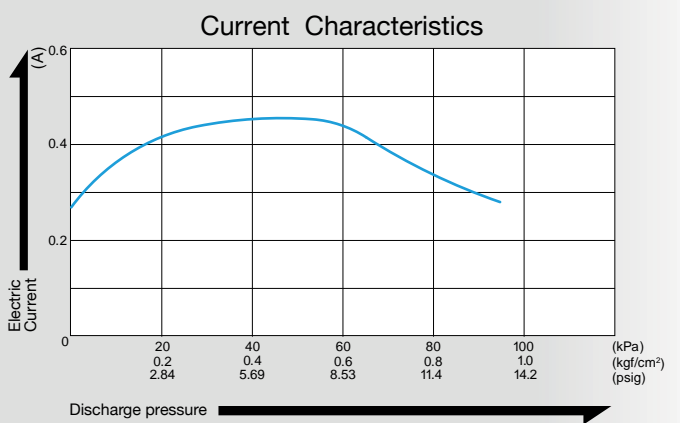
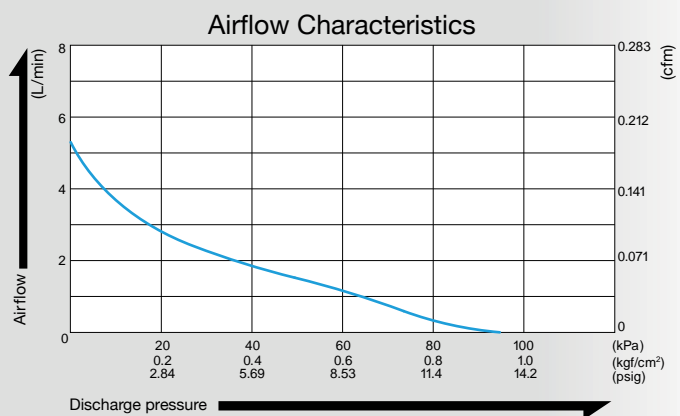

### Specifications

Free Air Displacement	4.0 L/min 0.141 cfm
Rated Voltage	12 V DC
Maximum Pressure	80 kPa (0.8 kgf/cm <sup>2</sup> ) 0.8 bar 11.4 psig
Maximum Current	0.7 A
Duty Cycle	Continuous
Working Pressure Range	0 to 80 kPa (0 to 0.8 kgf/cm <sup>2</sup> ) 0 to 0.8 bar 0 to 11.4 psig
Rated Performance (MTTF)	8,000 hours
Inlet	6 mm O.D. straight barb
Outlet	6 mm O.D. straight barb
Coil Insulation Class	E or its equivalent
Mounting Dimensions	50 (L) x 30 (W) mm 1 - 31/32" (L) x 1 - 3/16" (W)
Weight	0.25 kg 0.55 Lbs
Leadwire Length	400 mm 15 - 3/4"

### Application Examples

#### Removal of micromachining chips

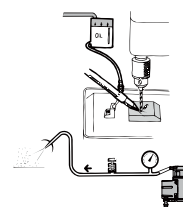

### External Dimensions (Unit: mm)

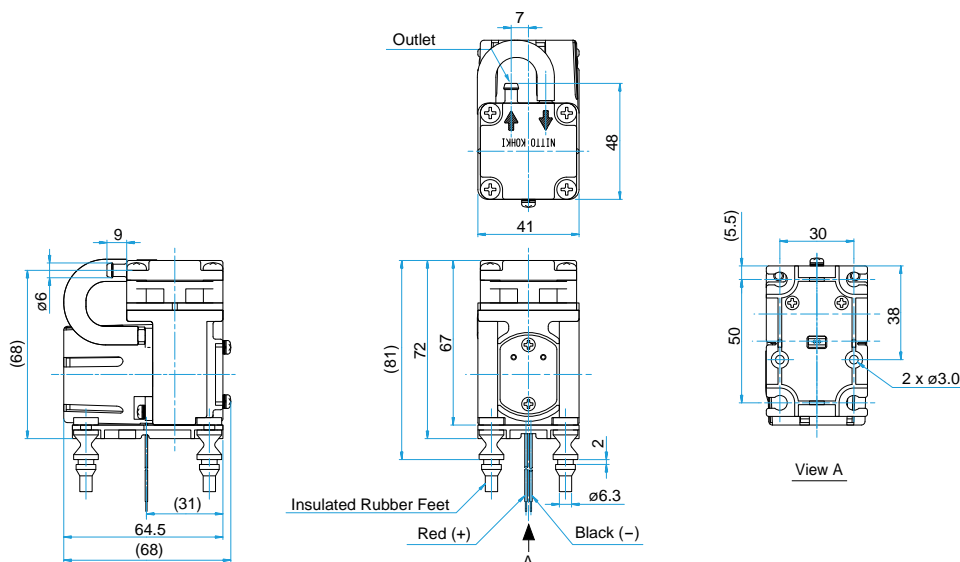

# Compressor and Vacuum Pump

## Model **DP0110-X1**

Brushless DC Motor 12 V DC



### Airflow & Power Consumption

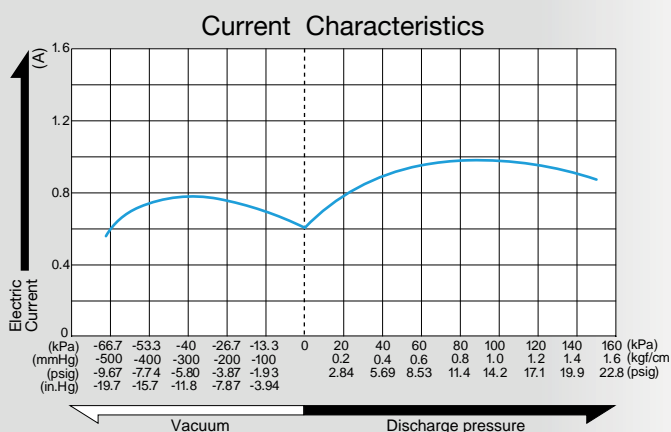
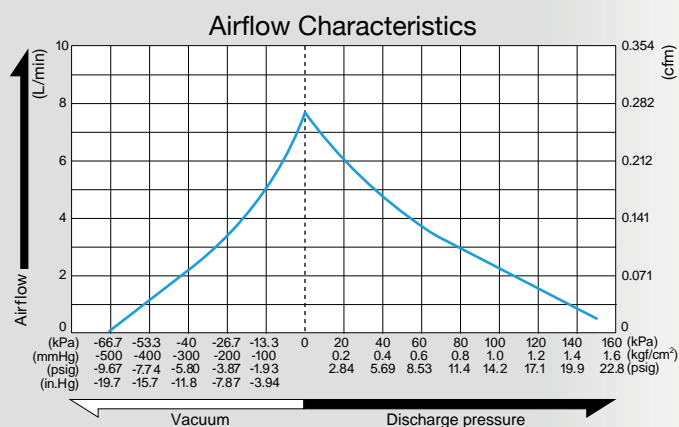

### Specifications

Attainable Vacuum	-66.7 kPa (-500 mmHg) -667 mbar -19.7 in.Hg
Free Air Displacement	7.5 L/min 0.265 cfm
Rated Voltage	12 V DC
Maximum Pressure	150 kPa (1.5 kgf/cm <sup>2</sup> ) 1.5 bar 21.3 psig
Maximum Current	1.2 A or less
Duty Cycle	Continuous
Rated Performance (MTTF)	8,000 hours
Inlet	6 mm O.D. straight barb
Outlet	6 mm O.D. straight barb
Coil Insulation Class	A or its equivalent
Mounting Dimensions	50 (L) x 30 (W) mm 1 - 31/32" (L) x 1 - 3/16" (W)
Weight	0.30 kg 0.66 Lbs
Leadwire Length	360 mm 14 - 11/64"

### Application Examples

Vacuum pick up and place devices for CD & DVD

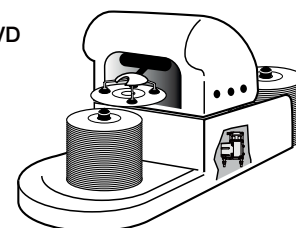

### External Dimensions (Unit: mm)

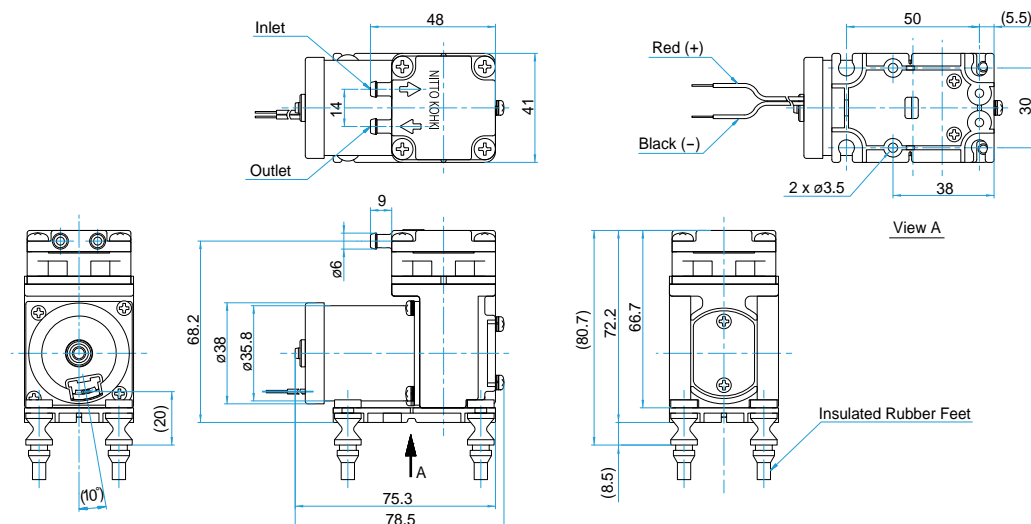

# Compressor and Vacuum Pump

## Model **DP0110-Y1**

Brushless DC Motor 24 V DC



### Airflow & Power Consumption

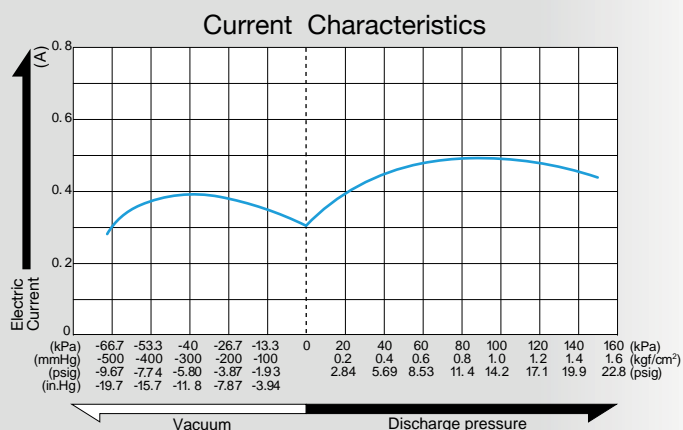
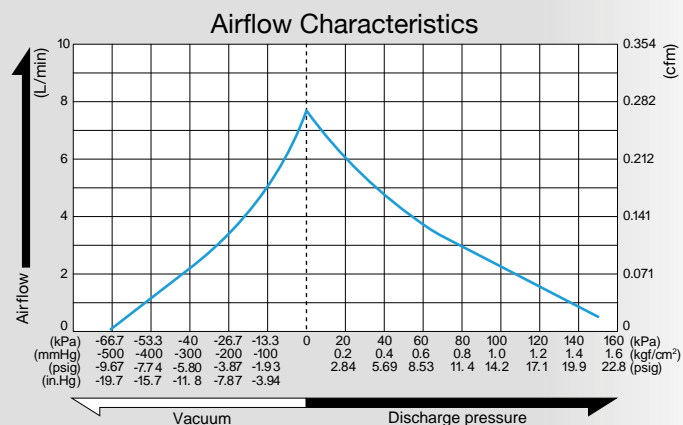

### Specifications

Attainable Vacuum	-66.7 kPa (-500 mmHg) -667 mbar -19.7 in.Hg
Free Air Displacement	7.5 L/min 0.265 cfm
Rated Voltage	24 V DC
Maximum Pressure	150 kPa (1.5 kgf/cm <sup>2</sup> ) 1.5 bar 21.3 psig
Maximum Current	0.6 A or less
Duty Cycle	Continuous
Rated Performance (MTTF)	8,000 hours
Inlet	6 mm O.D. straight barb
Outlet	6 mm O.D. straight barb
Coil Insulation Class	A or its equivalent
Mounting Dimensions	50 (L) x 30 (W) mm 1 - 31/32" (L) x 1 - 3/16" (W)
Weight	0.30 kg 0.66 Lbs
Leadwire Length	360 mm 14 - 11/64"

### Application Examples

Vacuum pick up and place devices for CD & DVD

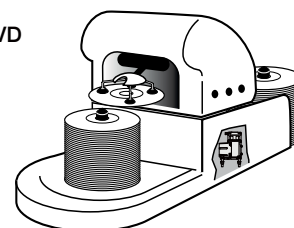

### External Dimensions (Unit: mm)

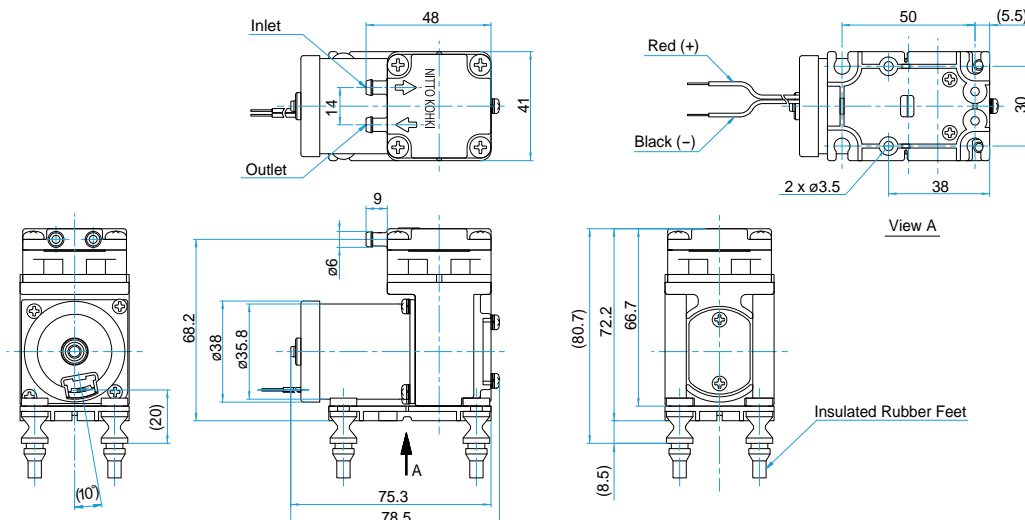

# Compressor and Vacuum Pump

## Model **DP0110-X3**

PWM controlled model



Brushless DC Motor 12 V DC

### Airflow & Power Consumption

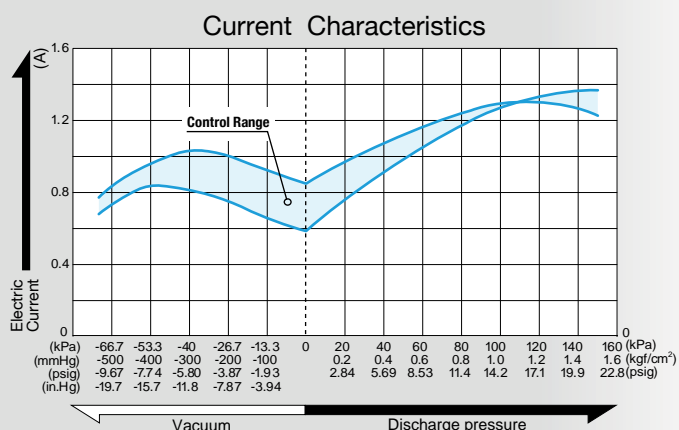
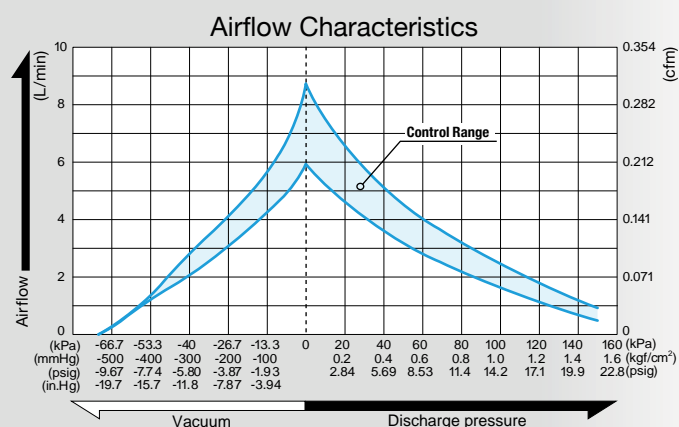

### Specifications

Attainable Vacuum	-66.7 kPa (-500 mmHg) -667 mbar -19.7 in.Hg
Free Air Displacement	7.5 L/min 0.265 cfm
Rated Voltage	12 V DC
Maximum Pressure	150 kPa (1.5 kgf/cm <sup>2</sup> ) 1.5 bar 21.3 psig
Maximum Current	1.4 A or less
Duty Cycle	Continuous
Rated Performance (MTTF)	8,000 hours
Control(PWM)	2.5 - 5 V, 15 - 25 kHz, Duty cycle 80 - 100%
Inlet	6 mm O.D. straight barb
Outlet	6 mm O.D. straight barb
Coil Insulation Class	A or its equivalent
Mounting Dimensions	50 (L) x 30 (W) mm 1 - 31/32" (L) x 1 - 3/16" (W)
Weight	0.30 kg 0.66 Lbs
Leadwire Length	180 mm 7 - 3/32"

### Application Examples

Vacuum pick up and place devices for CD & DVD

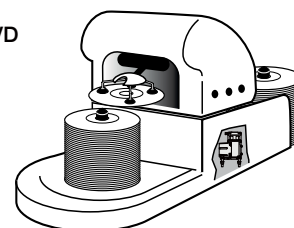

### External Dimensions (Unit: mm)

#### Mounting Dimension of Rubber Foot:

Plate thickness : t = 2 mm,  
Hole diameter :  $\phi 6 \pm 0.1$  mm  
(Rubber feet come with the product as accessories.)

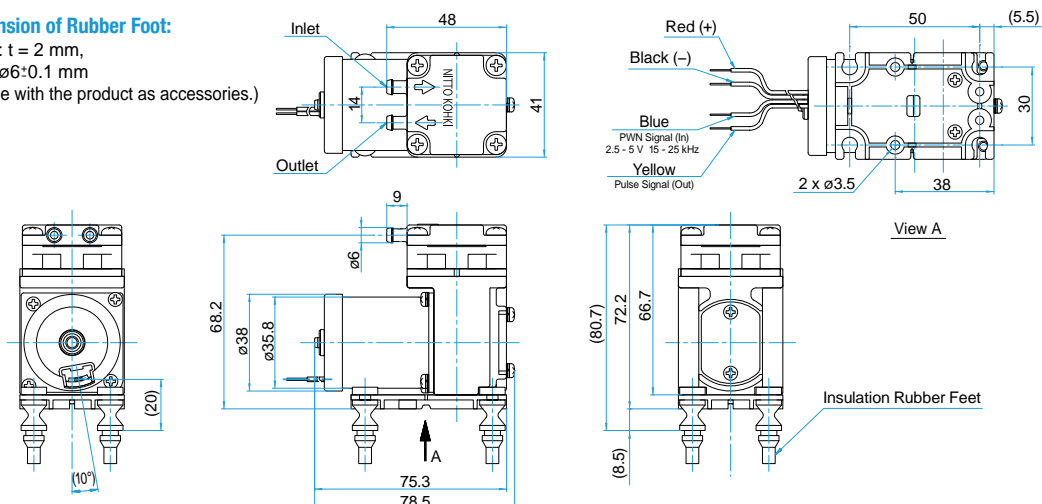



# Compressor and Vacuum Pump



## Model DP0110T-X1

Brushless DC Motor

12 V DC



### Airflow & Power Consumption

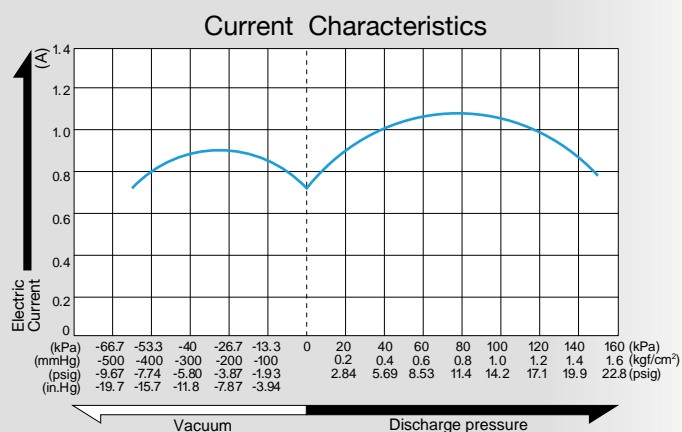
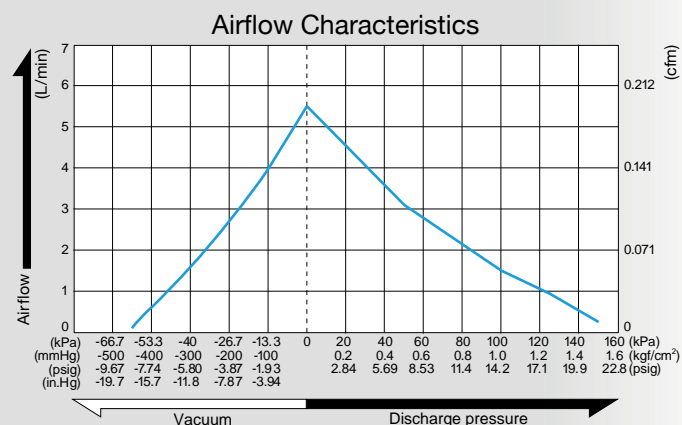

### Specifications

Attainable Vacuum	-60.0 kPa (-450 mmHg) -600 mbar -17.7 in.Hg
Free Air Displacement	5.5 L/min 0.194 cfm
Rated Voltage	12 V DC
Maximum Pressure	150 kPa (1.5 kgf/cm <sup>2</sup> ) 1.5 bar 21.3 psig
Maximum Current	1.2 A or less
Duty Cycle	Continuous
Rated Performance (MTTF)	5,000 hours
Inlet	6.8 mm O.D. straight barb
Outlet	6.8 mm O.D. straight barb
Coil Insulation Class	A or its equivalent
Mounting Dimensions	36.5 (L) x 37.5 (W) mm 1 - 7/16" (L) x 1 - 15/32" (W)
Weight	0.27 kg 0.60 Lbs
Leadwire Length	360 mm 14 - 11/64"

### Application Examples

#### Vending Machines

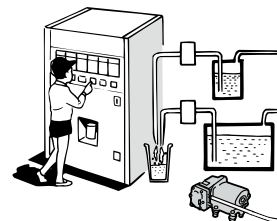

### External Dimensions (Unit: mm)

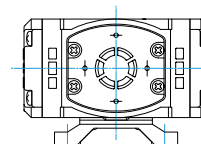
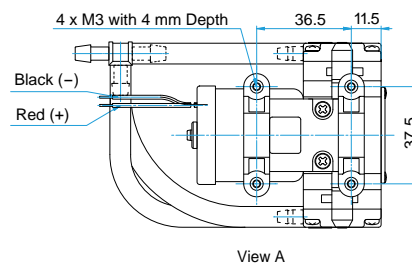
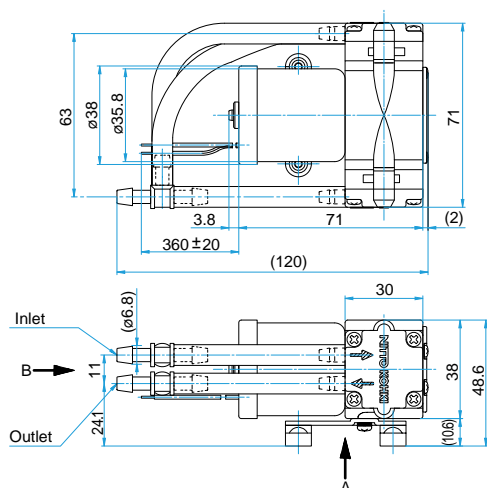
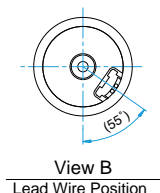

# Compressor and Vacuum Pump

## Model **DP0110T-Y1**



**Brushless DC Motor 24 V DC**

### Airflow & Power Consumption

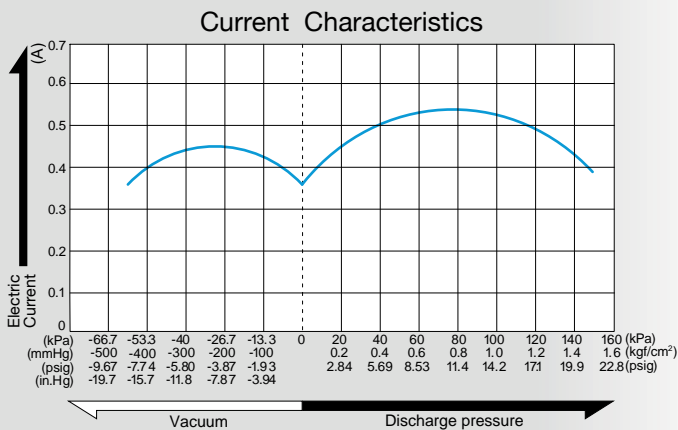
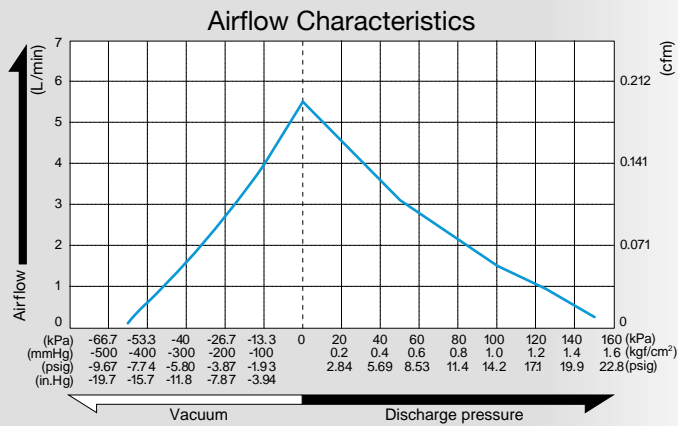

### Specifications

Attainable Vacuum	-60.0 kPa (-450 mmHg) -600 mbar -17.7 in.Hg
Free Air Displacement	5.5 L/min 0.194 cfm
Rated Voltage	24 V DC
Maximum Pressure	150 kPa (1.5 kgf/cm <sup>2</sup> ) 1.5 bar 21.3 psig
Maximum Current	0.6 A or less
Duty Cycle	Continuous
Rated Performance (MTTF)	5,000 hours
Inlet	6.8 mm O.D. straight barb
Outlet	6.8 mm O.D. straight barb
Coil Insulation Class	A or its equivalent
Mounting Dimensions	36.5 (L) x 37.5 (W) mm 1 - 7/16" (L) x 1 - 15/32" (W)
Weight	0.27 kg 0.60 Lbs
Leadwire Length	360 mm 14 - 11/64"

### Application Examples

#### Vending Machines

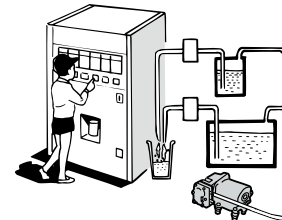

### External Dimensions (Unit: mm)

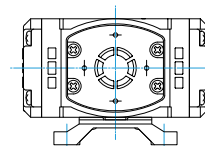
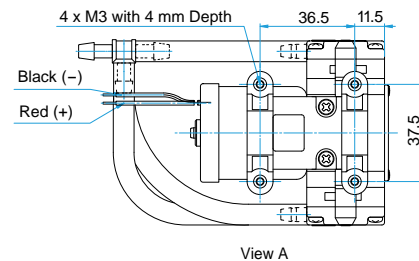
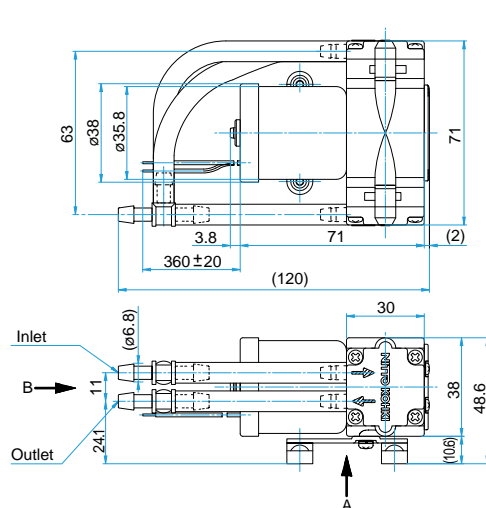
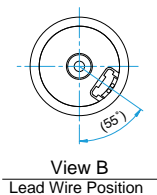

# Compressor and Vacuum Pump

## Model **DPO210TA-Y1** PWM controllable



Brushless DC Motor

24 V DC

### Airflow & Power Consumption

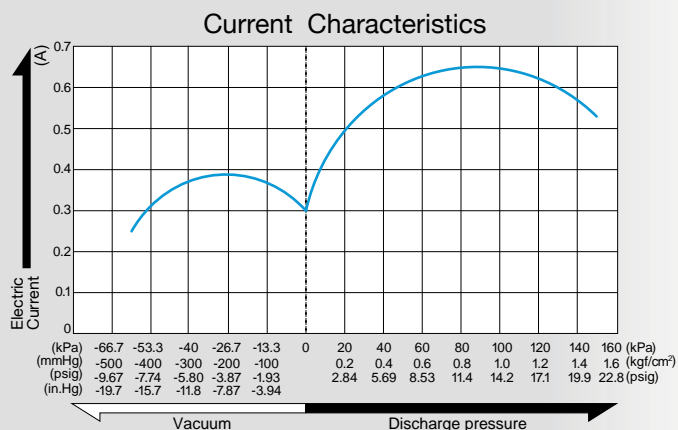
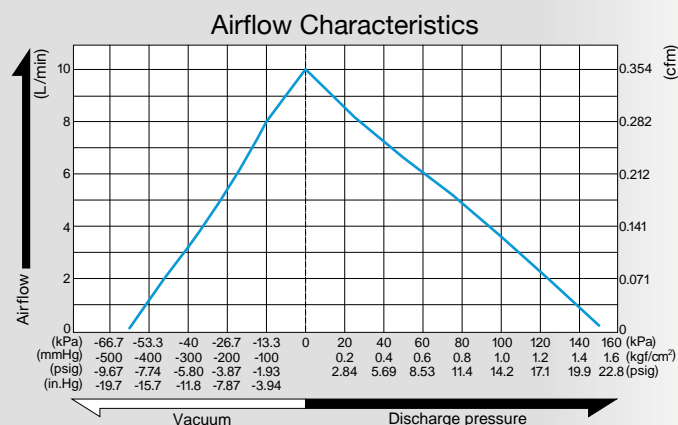

### Specifications

Attainable Vacuum	-60.0 kPa (-450 mmHg) -600 mbar -17.7 in.Hg
Free Air Displacement	10 L/min 0.35 cfm
Rated Voltage	24 V DC
Maximum Pressure	150 kPa (1.5 kgf/cm <sup>2</sup> ) 1.5 bar 21.3 psig
Maximum Current	0.8 A
Duty Cycle	Continuous
Rated Performance (MTTF)	5,000 hours
Inlet	6.8 mm O.D. straight barb
Outlet	6.8 mm O.D. straight barb
Coil Insulation Class	B or its equivalent
Mounting Dimensions	36.5 (L) x 37.5 (W) mm 1 - 7/16" (L) x 1 - 15/32" (W)
Weight	0.32 kg 0.71 Lbs
Leadwire Length	300 mm 11 - 13/16"

### Application Examples

#### Vending Machines

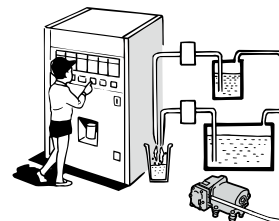

### External Dimensions (Unit: mm)

#### Connection Table

Circuit No.	1	2	3	4	5	6	7	8
Cord Color	—	Yellow	—	—	White	Blue	Black	Red
Connection Table	Control Signal				Power Source			
Function	—	FG	—	—	PWM	BRAKE	GND	VM
Cord Size	AWG28				AWG26			
Cord UL Style	UL1571							

#### No control function

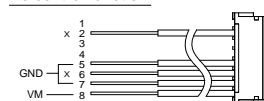

#### Use control function

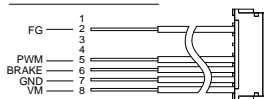

S8B-ZR-SM4A(JST) or 1027-66208(CNPLS) or 15001WR-08A00(YENHO)

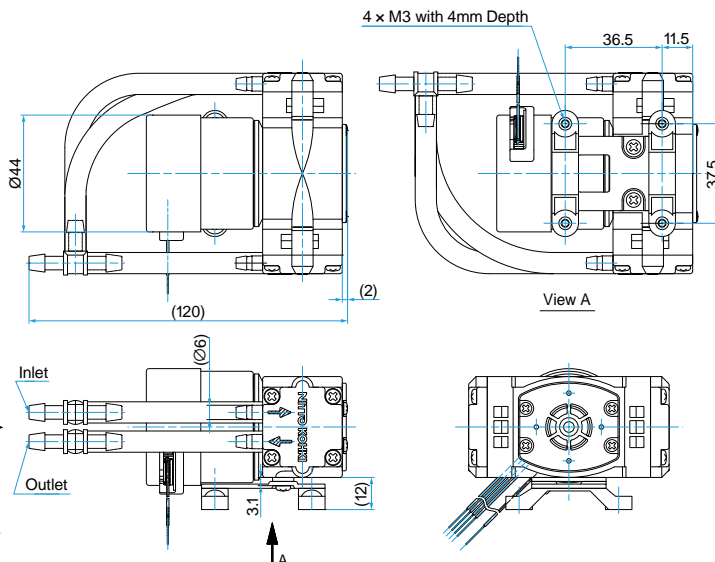
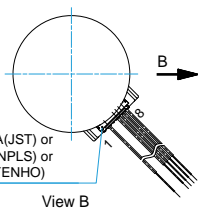



# LIQUID PUMP

Piezoelectric Pump  
DC Diaphragm Liquid Pump

# LIQUID PUMP

## Piezoelectric Pump

**BIMOR series**

## DC Diaphragm Liquid Pump

**DPE series**

Page

BPS Type  
BPH Type — 85  
BPHS Type  
BPF Type

Made to order model — 112

DPE-100 — 89  
DPE-400 — 90  
DPE-400BL — 91  
DPE-800 — 92

Liquid Pump series (120 V/240 V AC/DC)

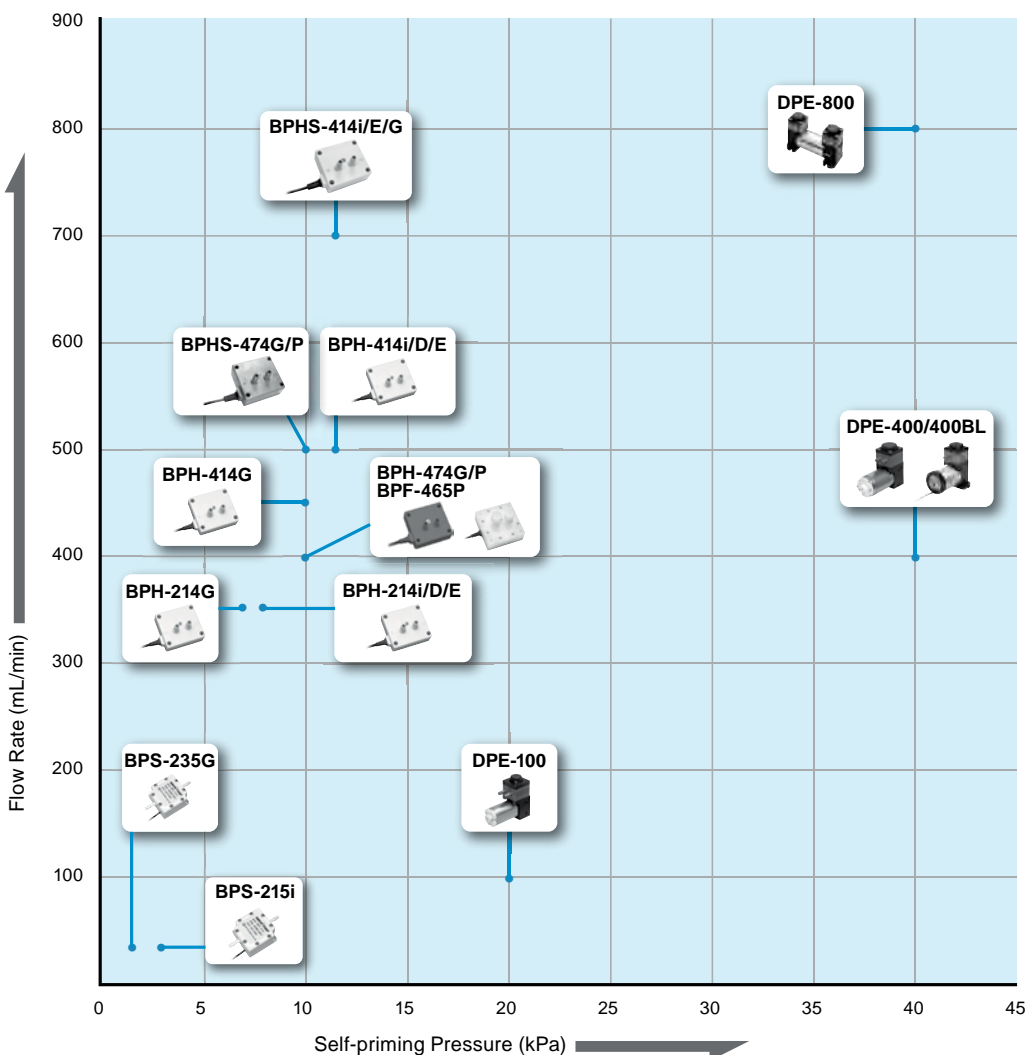

i : Butyl Rubber  
G : Fluorine Rubber  
D : Dimethyl rubber  
E : Ethylene Propylene Rubber  
P : Perfluor

# Piezoelectric Pump

## BIMOR PUMP

*Suitable for pumping liquids*



### Applications

- For water supply and drainage
- For cooling water circulation
- For chemical injection
- For liquid sampling

### Compact, lightweight, durable & quiet

As the Bimorph has no motors or shafts or other troublesome mechanisms. We have achieved maintenance free continuous operation for 60 months.

### Low power consumption & electromagnetic noise

The Bimor is driven by low energy consuming piezoelectric elements. Consequently it costs very little to run and emits virtually no electromagnetic noise.

### Simple flow rate adjustment

As the flow rate of the Bimor is proportional to the voltage and frequency, adjusting the flow rate is as simple as adjusting either one. You may use the product at the rated voltage or lower.

### Application versatility

The parts can be made of several different materials, so you can select the material appropriate to your needs, be it a liquid application. The Bimor is currently employed in a variety of different fields including medicine, scientific research, and the PC and chemical industries.

### External Dimensions (Unit: mm)

#### BPS type

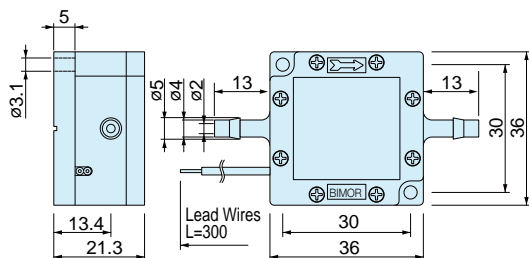

#### BPHS type

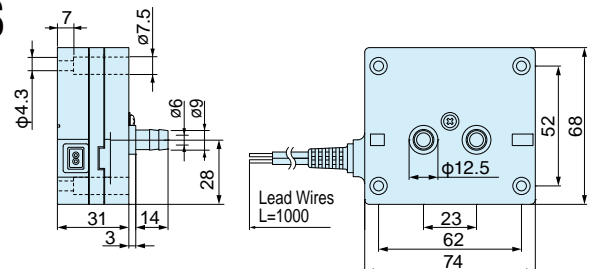

#### BPH type

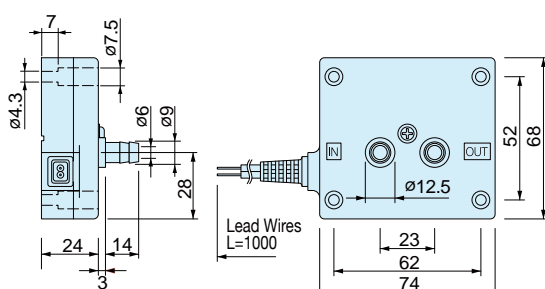

#### BPF type

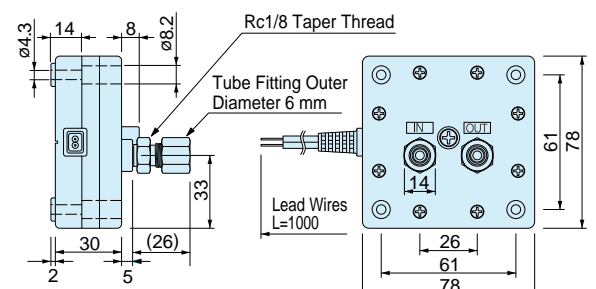

# Specifications

Voltage(AC) —120 V 60 Hz					Voltage(AC) —240 V 60 Hz					Material of Wetted Parts			Weight (g)
Model	Current (mA)	Self-priming Pressure (kPa) <sup>*1</sup>	Flow Rate (mL/min) <sup>*1</sup>	Discharge Pressure (kPa)	Model	Current (mA)	Self-priming Pressure (kPa) <sup>*1</sup>	Flow Rate (mL/min) <sup>*1</sup>	Discharge Pressure (kPa)	Housing	Liquid Contact Sheet	Valve / O-ring	
BPS-215i	3	3	30	15	—	—	—	—	—	PP	PP	IIR	40
BPH-214E	15	8	350	18	BPH-214E	7.5	8	350	18	PP	PP	EPDM	140
BPH-214G	15	7	350	17	BPH-214G	7.5	7	350	17	PP	PTFE	FKM	140
BPH-414E	30	12	500	35	—	—	—	—	—	PP	PP	EPDM	140
—	—	—	—	—	BPH-474G	15	10	400	35	PPS	PTFE	FKM	170
—	—	—	—	—	BPH-474P	15	10	400	35	PPS	PTFE	FFKM/FEP	170

\*1: The values in the specification shows the performance obtained using 25°C of water at 60 Hz. When the pump is used at 50 Hz, the flow rate will decrease approximately 20%.  
 When the liquid temperature is low, the check valve will harden. As a result, the flow rate and the self-priming pressure will decrease. Especially the flow rate of the pump with fluorine rubber will decrease by half at 5°C, so select with sufficient margin.  
 Since the flow rate will decrease with highly viscous liquids, please check the flow rate with an actual pump before use.

\*2: Please see page 112 for other made-to-order models.

## Condition of Use

Ambient temperature	5 to 50°C <sup>*1</sup>
Ambient humidity	35 to 85% <sup>*2</sup>
Fluid temperature	5 to 50°C

\*1: No Freezing  
 \*2: No condensation

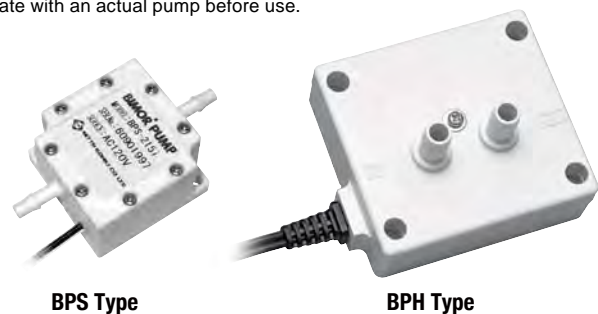

## The meaning of each letter in the model name

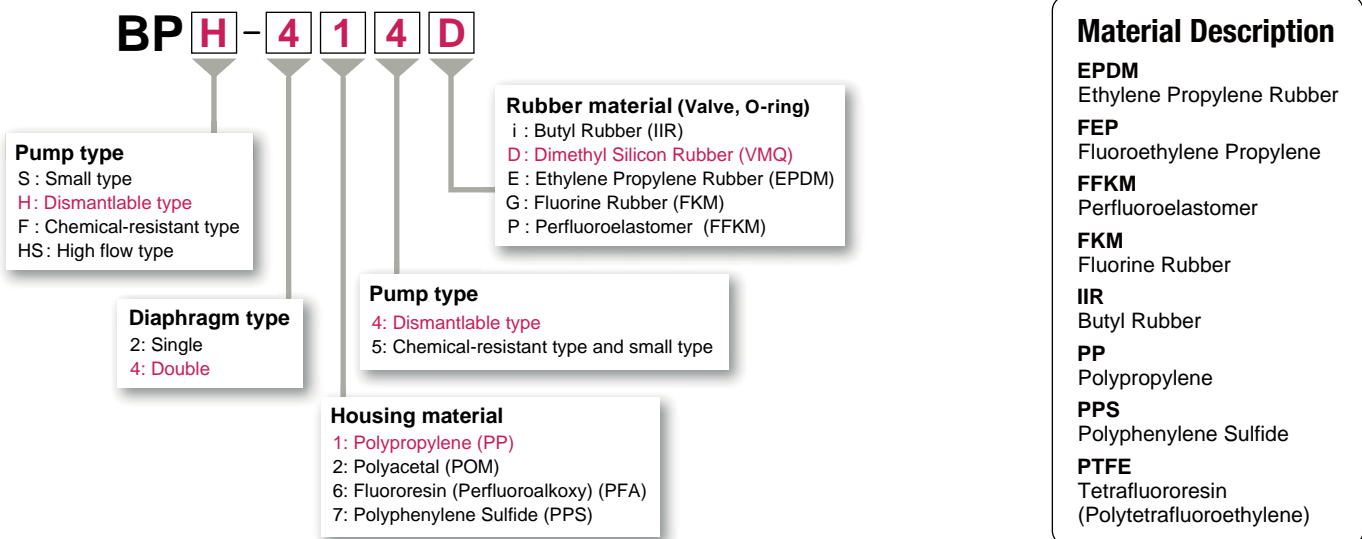

## Suitable/unsuitable chemical liquids

Model	Examples of suitable chemical liquids	Examples of unsuitable chemical liquids
BPS-215i	Ethanol, Dilute hydrochloric acid, Sodium carbonate, Benzaldehyde, Formalin	Xylene, Mineral oil, Carbon tetrachloride, Trichloroethylene, Toluene, Benzene
BPH-214E BPH-414E	Ammonia water, Ethanol, Dilute hydrochloric acid, Caustic potash, Caustic soda, Methanol	
BPH-214G	Ethanol, Hydrogen peroxide, Mineral oil, Sodium hypochlorite	Acetone, Ammonia water, Glacial acetic acid, Hydrofluoric acid, Formalin
BPH-474G	Ethanol, Xylene, Carbon tetrachloride, Silicone oil, Trichloroethylene	Acetone, Ammonia water, Chlorosulfonic acid, Glacial acetic acid, Hydrofluoric acid, Formalin
BPH-474P	Ethanol, Chloroform, Glacial acetic acid, Benzene, Methyl ethyl ketone	Chlorosulfonic acid, Fluorine oil, CFC 112, CFC 113

\*This chart is for reference only. Please confirm under the operating conditions before use.

# The Next Step in Pump Miniaturization



## Revolutionary piezoelectric bimorph technology

The BIMOR pump's driving force, the bimorph, comprises two parallel piezoelectric wafers. Their nature is to expand or contract depending on the direction of the voltage. Therefore when an alternating current is applied, one wafer expands then contracts while the other contracts then expands, causing the bimorph to bend. Repeating the cycle creates the pumping action.

### Cross section

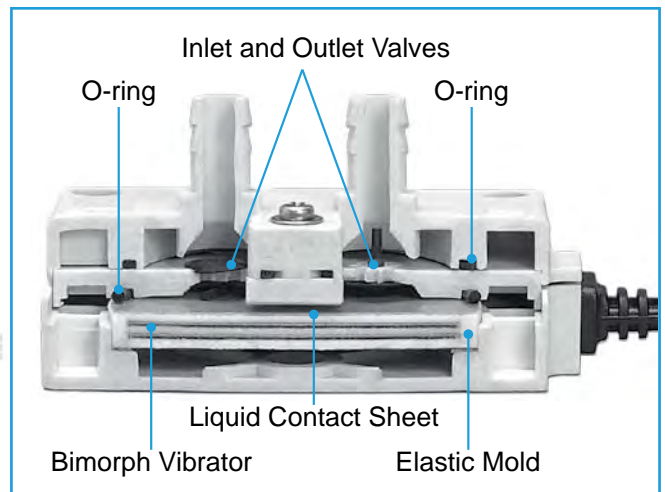

### Principle / Structure

"The Bimor pump" uses the displacement operation of the piezoelectric bimorph vibrator as the direct source of the pumping action.

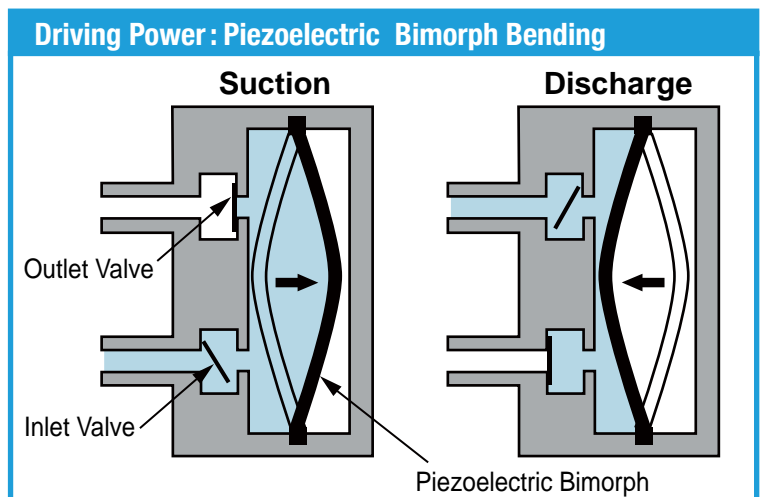



# DC Liquid Pump

## DPE series



- **Built-in Pulse Absorption Chamber**
- **Many build material options for different liquids**
- **Self-priming type with air suction acceptable**

### Typical Conventional Pump without Pulse Absorption

As liquid is transported through the suction and discharge passages of the pump and liquid circuit, high pulsations can be created which can cause cavitation, vibration in tubing, fittings, peak pulsing noises, and added stress and wear to pump mechanisms. These negative results are often increased through the use of small pumps having relatively high rotational speeds.

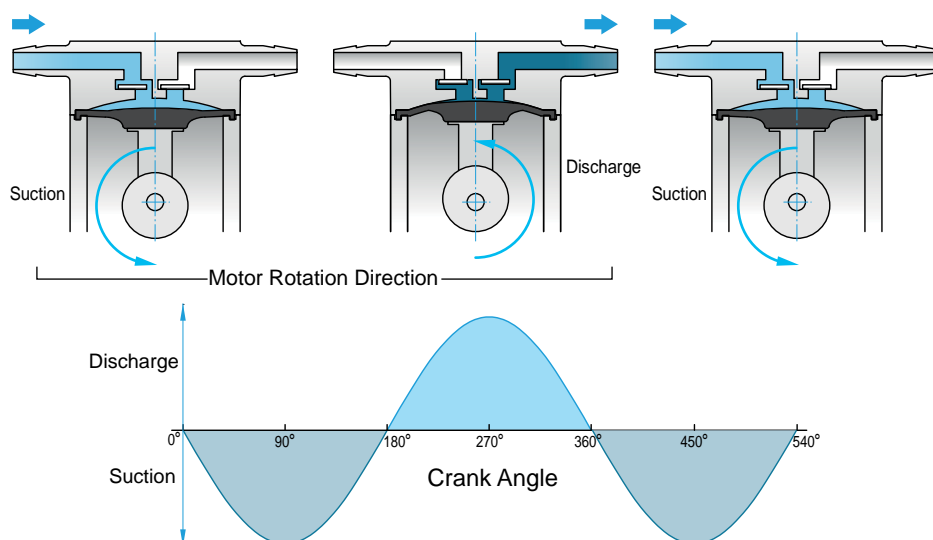

### Advanced design DPE Pump with Pulse Absorption

Provides pulse attenuation which helps to create steady state flow, reduced noise and vibration throughout the fluid circuit, and enhances life of the pump and other circuit components. It's designed in. . . No need for additional installation cost or space with pulsation dampers.

① Suction

② Discharge. Partial fluid delivery to pulse absorption chamber, not directly forced to outlet port.

③ Cyclical suction drawn into pump is synchronized with the discharge.

Pulses are attenuated through the process of ② and ③.

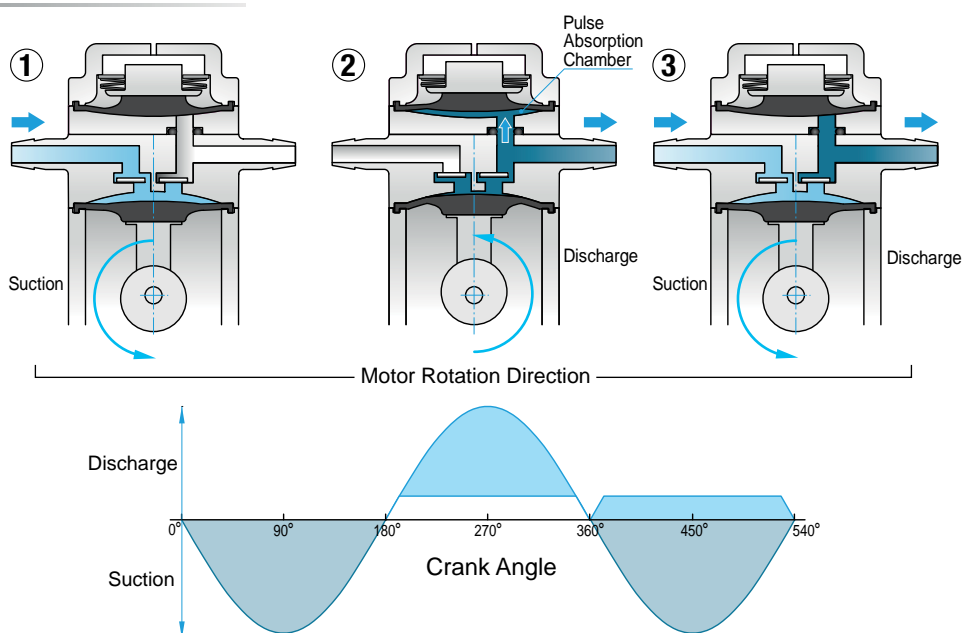

# DC Liquid Pump

## Model **DPE-100**

Brush DC Motor 24 V DC



### Flow & Electric Current

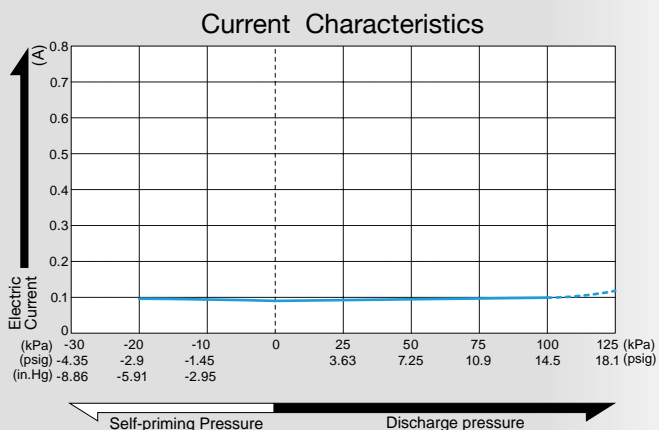
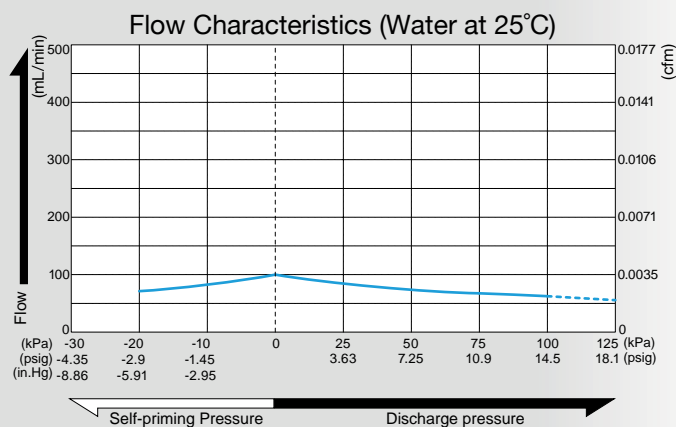

### Specifications

Rated Voltage	24 V DC
Flow Rate <sup>*1</sup>	100 mL/min 0.0035 cfm
Working Pressure Range	0 to 100 kPa 0 to 1 bar 0 to 14.2 psig
Maximum Pressure <sup>*2</sup>	300 kPa 3 bar 42.7 psig
Maximum Current	100 mA
Duty Cycle	Continuous
Rated Performance (MTTF)	500 hours
Self-priming Pressure <sup>*1</sup>	20 kPa 0.2 bar 2.84 psig
Inlet	4.7 mm O.D. straight barb
Outlet	4.7 mm O.D. straight barb
Insulation Classification	E class equivalent
Mounting Dimensions	9.5 (L) x 17 (W) mm 3/8" (L) x 43/64" (W)
Weight	67 g 0.148 Lbs
Motor	Brush DC Motor

<sup>\*1</sup>. When the check valve is hardened due to low liquid temperature, self-priming performance and flow rate will go down.  
<sup>\*2</sup>. Restarting pumps with flow passage closed is impossible.

### Material of wetted parts and applicable fluids

Model	Cylinder Head	Head Cover	Diaphragm	Valve	O-ring	Applicable fluids
DPE-100-2E	PA Polyamide(Nylon)	PTFE	Polytetrafluoroethylene	EPDM	Ethylene-propylene rubber	Sodium hydroxide, Citric acid Ammonia water, Caustic potash
DPE-100-2G				FKM	Fluoro rubber	Ethanol, Ethylene glycol Sodium carbonate, mineral oil
DPE-100-7G	PPS Polyphenylene sulfide	PTFE	Polytetrafluoroethylene	FFKM	Perfluoroelastomer	Xylene, Carbon tetrachloride Trichloroethylene, Silicon oils
DPE-100-7P				FFKM	Perfluoroelastomer	Chloroform, Benzene Glacial acetic acid, Methyl ethyl ketone

### Application Examples

- Liquid analytical instruments e.g. medical, food, water treatment & environmental.
- Liquid transport within filtration, sampling, sterilizers and washers.
- Ink transport within industrial ink-jet printers.

### External Dimensions (Unit: mm)

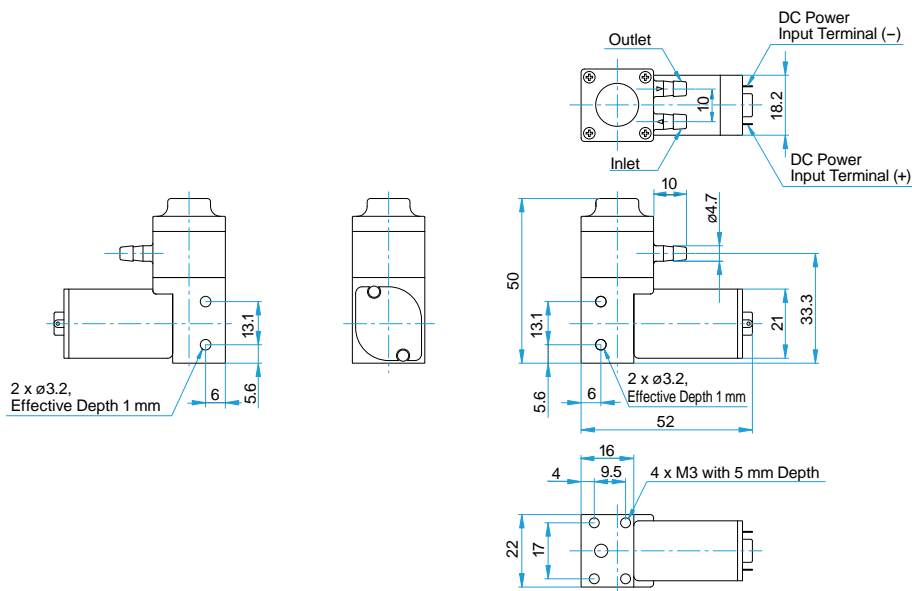

# DC Liquid Pump

## Model **DPE-400**

Brush DC Motor 24 V DC



### Flow & Electric Current

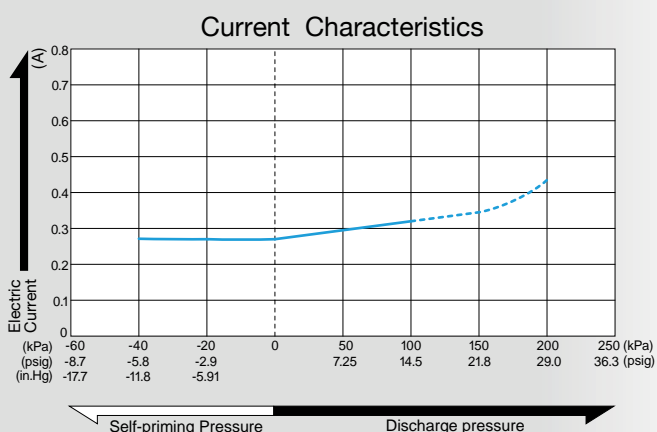
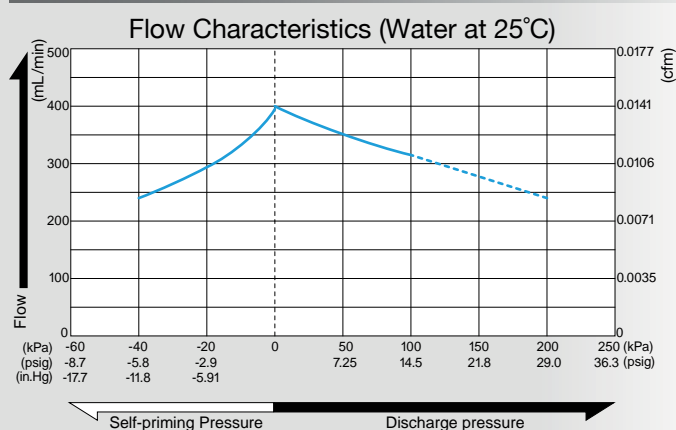

### Specifications

Rated Voltage	24 V DC
Flow Rate *1	400 mL/min 0.0141 cfm
Working Pressure Range	0 to 100 kPa 0 to 1 bar 0 to 14.2 psig
Maximum Pressure *2	300 kPa 3 bar 42.7 psig
Maximum Current	345 mA
Duty Cycle	Continuous
Rated Performance (MTTF)	500 hours
Self-priming Pressure *1	40 kPa 0.4 bar 5.69 psig
Inlet	5.4 mm O.D. straight barb
Outlet	5.4 mm O.D. straight barb
Insulation Classification	F class equivalent
Mounting Dimensions	19 (L) x 26 (W) mm 3/4" (L) x 1 - 1/32" (W)
Weight	187 g 0.412 Lbs
Motor	Brush DC Motor

\*1. When the check valve is hardened due to low liquid temperature, self-priming performance and flow rate will go down.  
\*2. Restarting pumps with flow passage closed is impossible.

### Material of wetted parts and applicable fluids

Model	Cylinder Head	Head Cover	Diaphragm	Valve	O-ring	Applicable fluids
DPE-400-2E	PA Polyamide(Nylon)		PTFE	EPDM Ethylene-propylene rubber		Sodium hydroxide, Citric acid Ammonia water, Caustic potash
DPE-400-2G				FKM Fluoro rubber		Ethanol, Ethylene glycol Sodium carbonate, mineral oil
DPE-400-7G	PPS Polyphenylene sulfide		Polytetrafluoroethylene	FFKM Perfluoroelastomer		Xylene, Carbon tetrachloride Trichloroethylene, Silicon oils
DPE-400-7P						

### Application Examples

- Liquid analytical instruments e.g. medical, food, water treatment & environmental.
- Liquid transport within filtration, sampling, sterilizers and washers.
- Ink transport within industrial ink-jet printers.

### External Dimensions (Unit: mm)

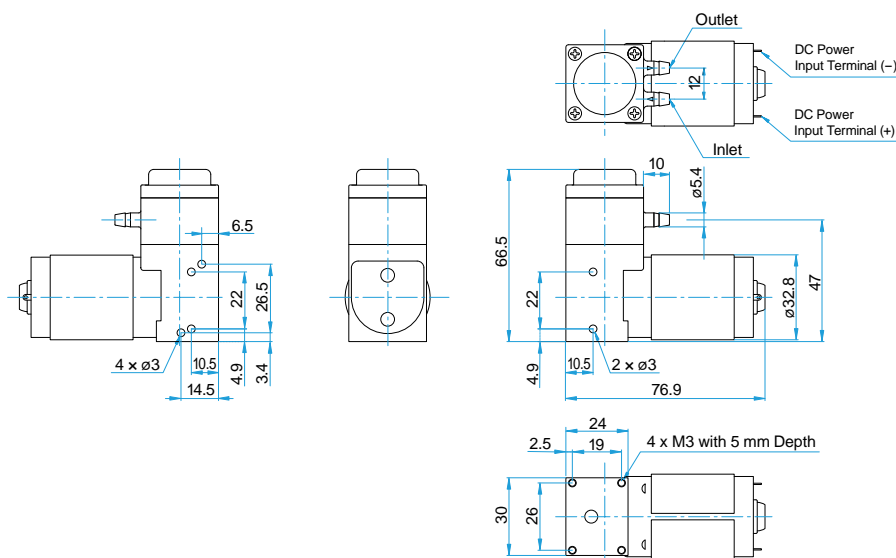

# DC Liquid Pump

## Model **DPE-400BL**

Brushless DC Motor 12 V / 24 V DC



### Flow & Electric Current

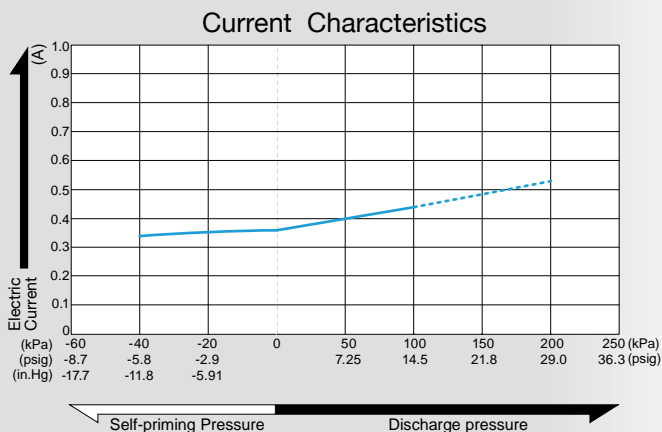
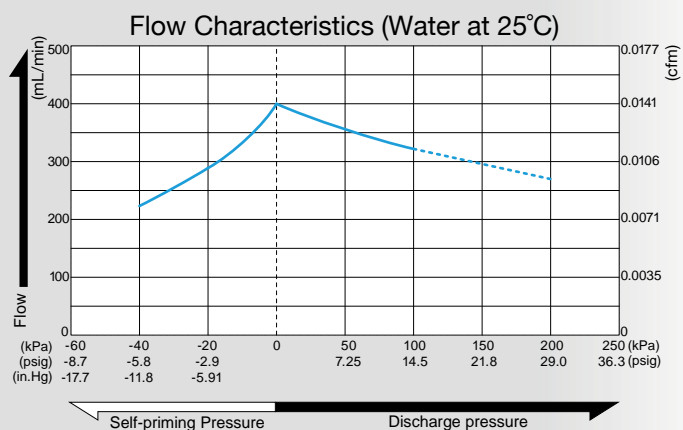

### Specifications

Rated Voltage	12 V / 24 V DC
Flow Rate *1	400 mL/min 0.0141 cfm
Working Pressure Range	0 to 100 kPa 0 to 1 bar 0 to 14.2 psig
Maximum Pressure *2	300 kPa 3 bar 42.7 psig
Maximum Current	900 / 450 mA
Duty Cycle	Continuous
Rated Performance (MTTF)	6,000 hours
Self-priming Pressure *1	40 kPa 0.4 bar 5.69 psig
Inlet	5.4 mm O.D. straight barb
Outlet	5.4 mm O.D. straight barb
Insulation Classification	A class equivalent
Mounting Dimensions	41 (W) mm 1 - 39/64 "(W)
Weight	230 g 0.507 Lbs
Motor	Brushless DC Motor

\*1. At low temperature, the performance may reduce.  
\*2. Pumps may not re-start against high backpressure.

### Material of wetted parts and applicable fluids

Model	Cylinder Head	Head Cover	Diaphragm	Valve	O-ring	Applicable fluids
DPE-400BL-2E	PA Polyamide(Nylon)	PTFE	Polytetrafluoroethylene	EPDM Ethylene-propylene rubber	FKM Fluoro rubber	Sodium hydroxide, Citric acid Ammonia water, Caustic potash
DPE-400BL-2G				FKM Fluoro rubber		Ethanol, Ethylene glycol Sodium carbonate, mineral oil
DPE-400BL-7G	PPS Polyphenylene sulfide	PTFE	Polytetrafluoroethylene	FKM Fluoro rubber	FFKM Perfluoroelastomer	Xylene, Carbon tetrachloride Trichloroethylene, Silicon oils
DPE-400BL-7P				FFKM Perfluoroelastomer		Chloroform, Benzene Glacial acetic acid, Methyl ethyl ketone

### Application Examples

- Liquid analytical instruments e.g. medical, food, water treatment & environmental.
- Liquid transport within filtration, sampling, sterilizers and washers.
- Ink transport within industrial ink-jet printers.

### External Dimensions (Unit: mm)

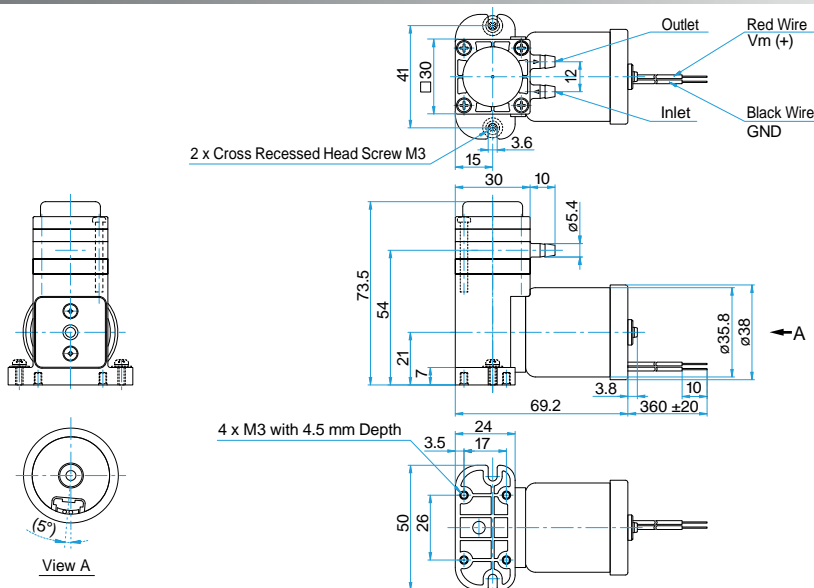

# DC Liquid Pump

## Model **DPE-800**

Brush DC Motor 24 V DC



### Flow & Electric Current

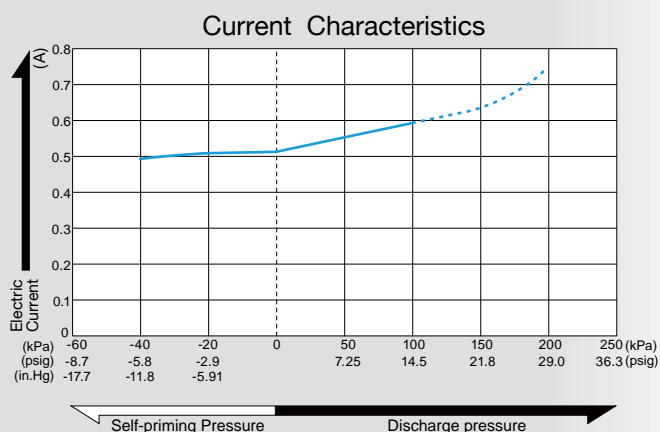
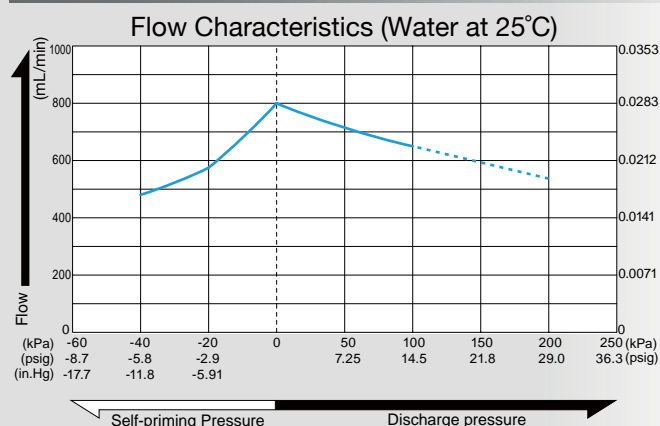

### Specifications

Rated Voltage	24 V DC
Flow Rate *1	800 mL/min 0.0283 cfm
Working Pressure Range	0 to 100 kPa 0 to 1 bar 0 to 14.2 psig
Maximum Pressure *2	300 kPa 3 bar 42.7 psig
Maximum Current	600 mA
Duty Cycle	Continuous
Rated Performance (MTTF)	600 hours
Self-priming Pressure *1	40 kPa 0.4 bar 5.69 psig
Inlet	5.4 mm O.D. straight barb
Outlet	5.4 mm O.D. straight barb
Insulation Classification	E class equivalent
Mounting Dimensions	74.5 (L) x 41 (W) mm 2 - 15/16" (L) x 1 - 39/64" (W)
Weight	350 g 0.771 Lbs
Motor	Brush DC Motor

\*1. When the check valve is hardened due to low liquid temperature, self-priming performance and flow rate will go down.  
\*2. Restarting pumps with flow passage closed is impossible.  
\*3. Tubing between two pumping heads must be done in parallel. Tubing in series between the two pumping heads should not be made. This may cause extreme pressure hike that will result in broken parts, liquid splash out or possible ignition.

### Material of wetted parts and applicable fluids

Model	Cylinder Head	Head Cover	Diaphragm	Valve	O-ring	Applicable fluids
DPE-800-2E	PA Polyamide(Nylon)	PTFE	Polytetrafluoroethylene	EPDM	Ethylene-propylene rubber	Sodium hydroxide, Citric acid Ammonia water, Caustic potash
DPE-800-2G				FKM	Fluoro rubber	Ethanol, Ethylene glycol Sodium carbonate, mineral oil
DPE-800-7G	PPS Polyphenylene sulfide	PTFE	Polytetrafluoroethylene	FFKM	Perfluoroelastomer	Xylene, Carbon tetrachloride Trichloroethylene, Silicon oils
DPE-800-7P				FFKM	Perfluoroelastomer	Chloroform, Benzene Glacial acetic acid, Methyl ethyl ketone

### Application Examples

- Liquid analytical instruments e.g. medical, food, water treatment & environmental.
- Liquid transport within filtration, sampling, sterilizers and washers.
- Ink transport within industrial ink-jet printers.

### External Dimensions (Unit: mm)

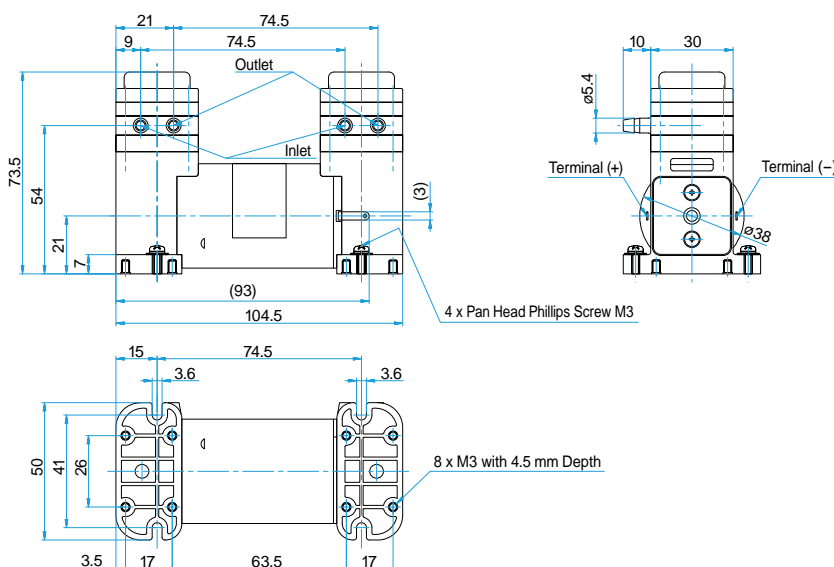



# MEDO BLOWER

**LA series**

LA-28B — 95  
 LA-45C — 95  
 LA-60B — 96  
 LA-80B — 96  
 LA-100A — 97  
 LA-120A — 97  
 LAM-200 — 98

Made to Order  
 LAM-150 — 111

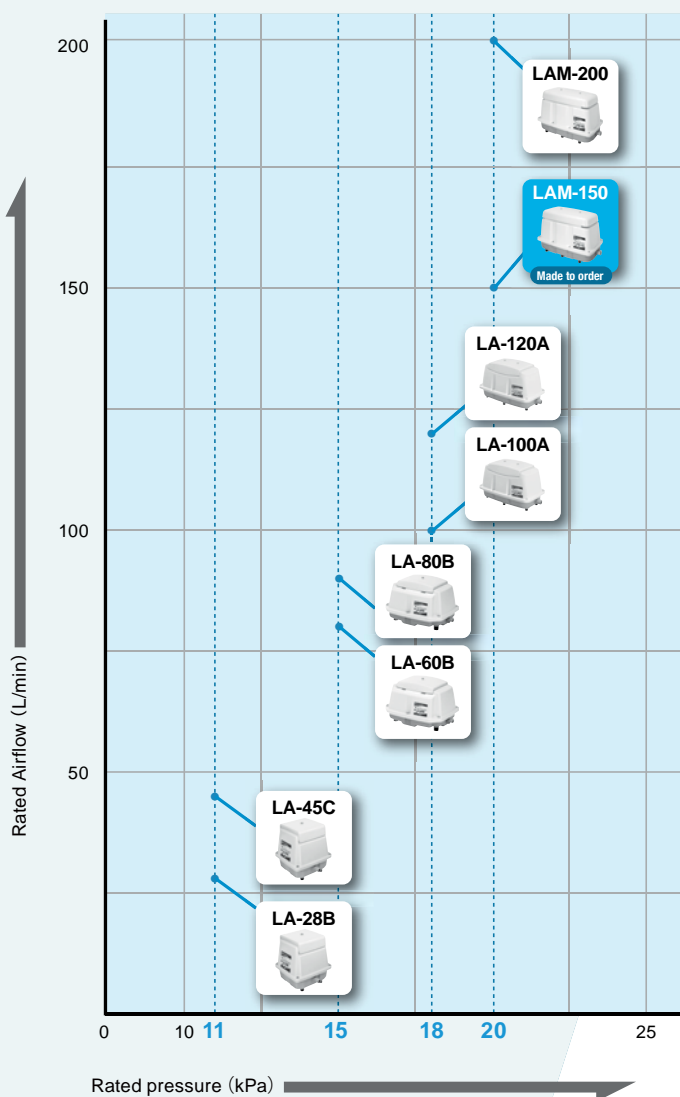

# MEDO BLOWER

## Model LA-28B & LA-45C



### Airflow Characteristics

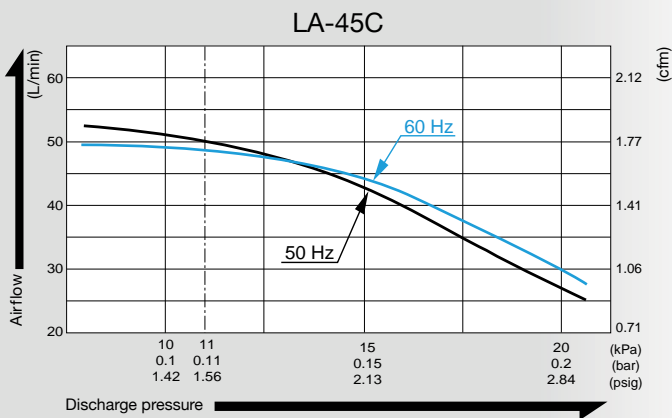
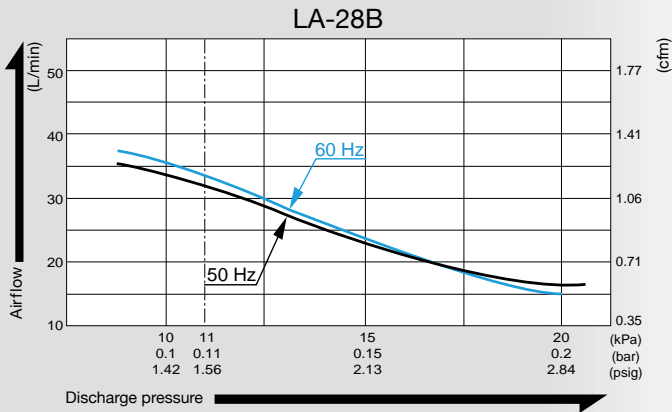

### Specifications

	LA-28B		LA-45C	
Power Supply	120 V AC	230/240 V AC	120 V AC	230/240 V AC
Rated Frequency	60 Hz	50 Hz	60 Hz	50 Hz
Power Consumption	25.5 W	29 W	45 W	47 W
Rated Pressure	11 kPa (0.11 kgf/cm <sup>2</sup> ) 0.11 bar 1.56 psig			
Rated Airflow	28 L/min 0.99 cfm		45 L/min 1.59 cfm	
Weight	2.9 kg 6.4 Lbs		3.2 kg 7.1 Lbs	

### Optional Hose Assemblies

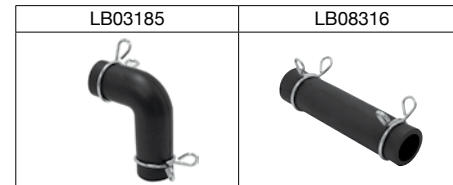

### Application Examples

#### Liquid Mixer Bubbling

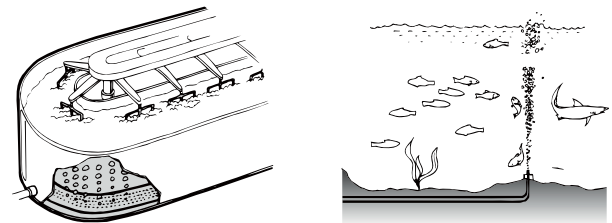

### External Dimensions (Unit: mm)

LA-28B

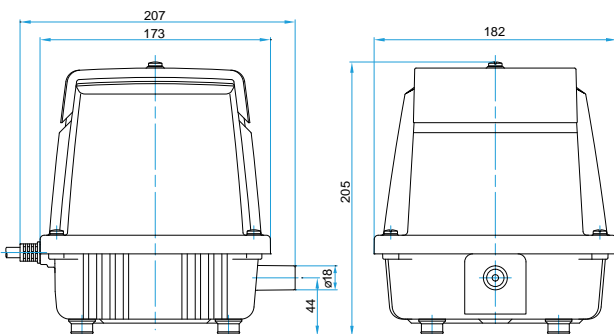

LA-45C

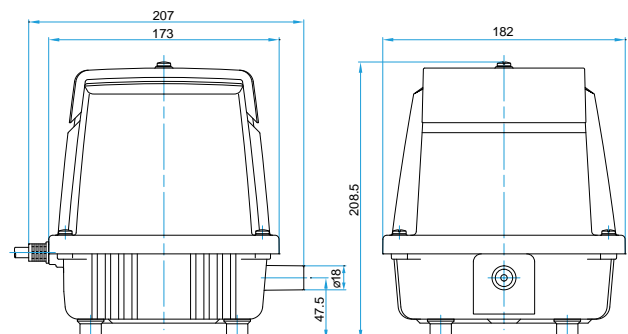



# MEDO BLOWER

## Model **LA-60B & LA-80B**



### Airflow Characteristics

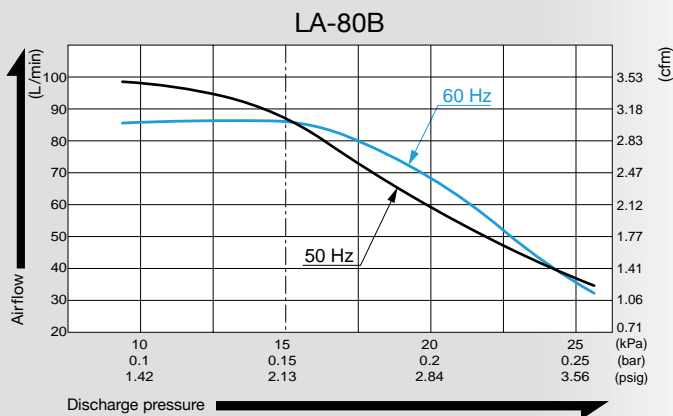
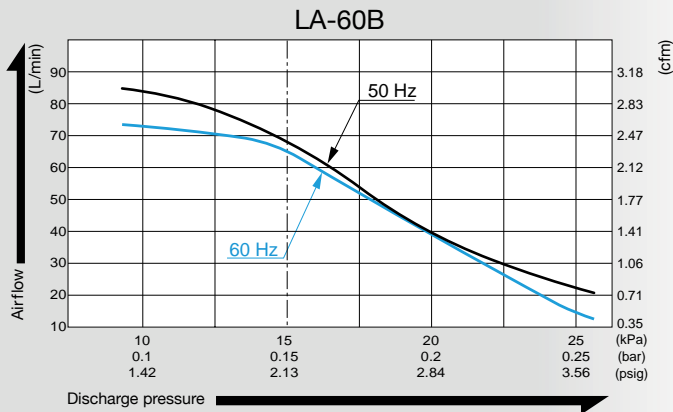

### Specifications

	LA-60B		LA-80B	
Power Supply	120 V AC	220/230/240 V AC	120 V AC	220/230/240 V AC
Rated Frequency	60 Hz	50 Hz	60 Hz	50 Hz
Power Consumption	60 W	64 W	80 W	86 W
Rated Pressure	15 kPa (0.15 kgf/cm <sup>2</sup> ) 0.15 bar 2.13 psig			
Rated Airflow	60 L/min 2.12 cfm		80 L/min 2.83 cfm	
Weight	5.0 kg 11 Lbs		5.3 kg 11.7 Lbs	

### Optional Hose Assemblies

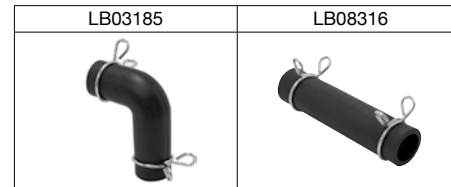

### Application Examples

#### Liquid Mixer Bubbling

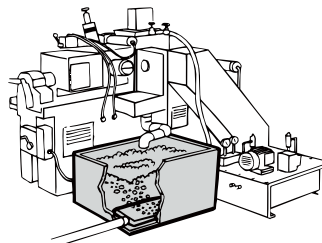

#### Home Aerobic Sewage Treatment System

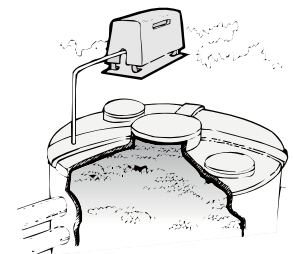

### External Dimensions (Unit: mm)

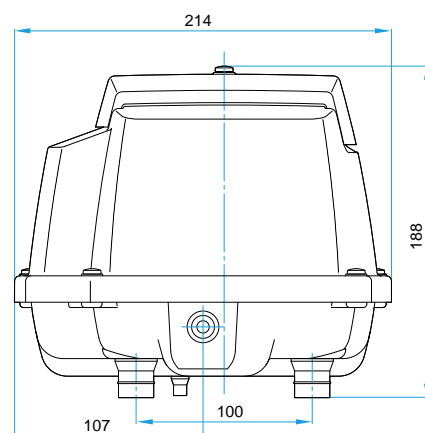
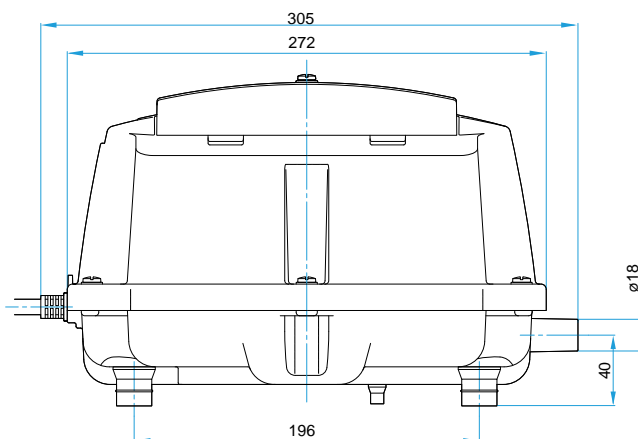

# MEDO BLOWER

## Model LA-100A & LA-120A

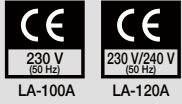

### Airflow Characteristics

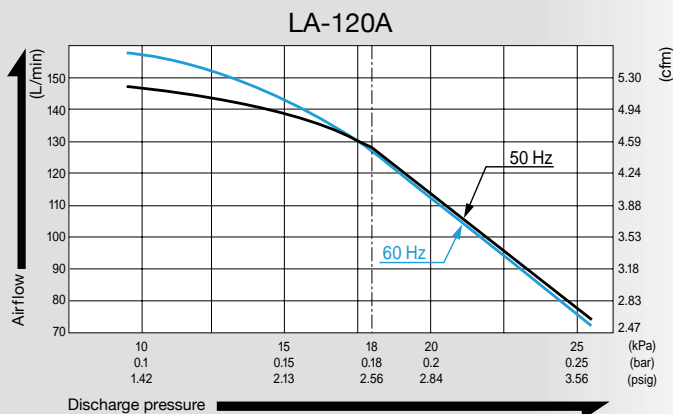
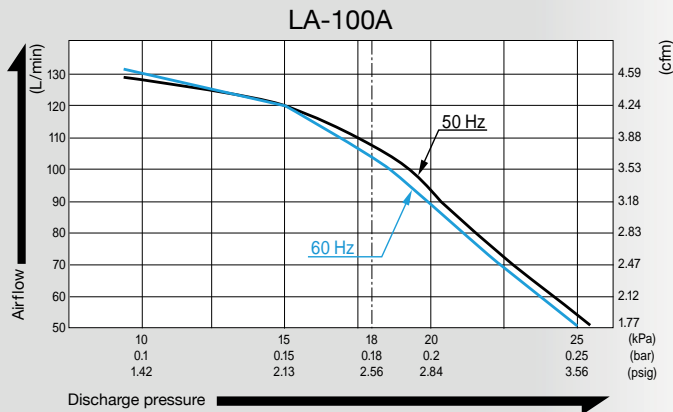

### Specifications

	LA-100A		LA-120A	
Power Supply	120 V AC	230/240 V AC	120 V AC	230/240 V AC
Rated Frequency	60 Hz	50 Hz	60 Hz	50 Hz
Power Consumption	95 W	100 W	118 W	130 W
Rated Pressure	18 kPa (0.18 kgf/cm <sup>2</sup> ) 0.18 bar 2.56 psig			
Rated Airflow	100 L/min 3.53 cfm		120 L/min 4.24 cfm	
Weight	9.7 kg 21.4 Lbs			

### Optional Hose Assemblies

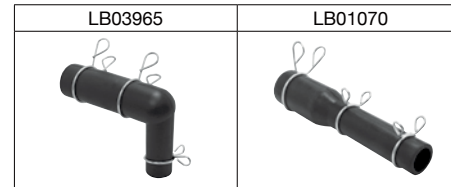

### Application Examples

#### Liquid Mixer Bubbling

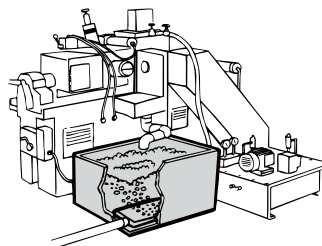

#### Home Aerobic Sewage Treatment System

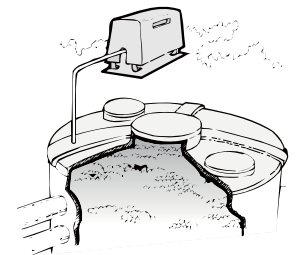

### External Dimensions (Unit: mm)

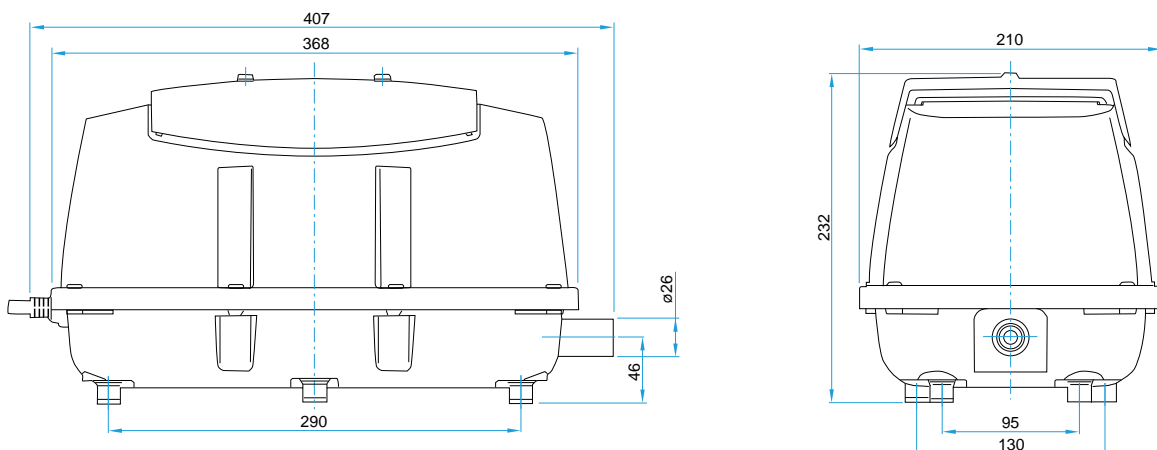

# MEDO BLOWER

## Model **LAM-200**



LAM-200

### Airflow Characteristics

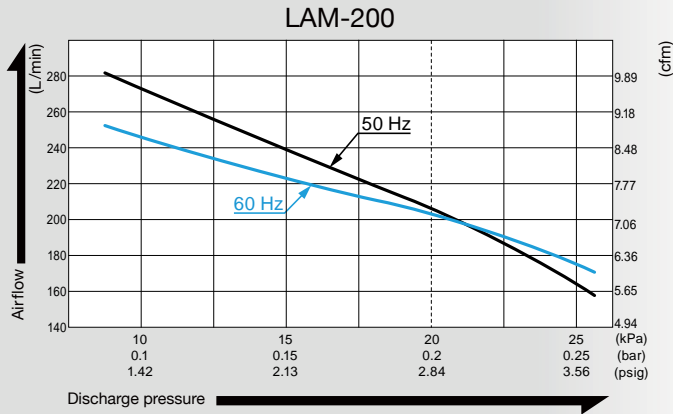

### Specifications

LAM-200	
Power Supply	120 V AC      230/240 V AC
Rated Frequency	60 Hz            50 Hz
Power Consumption	215 W
Rated Pressure	20 kPa (0.2 kgf/cm <sup>2</sup> ) 0.2 bar 2.84 psig
Rated Airflow	200 L/min 7.06 cfm
Weight	12.3 kg 27.1 Lbs

### Optional Hose Assemblies

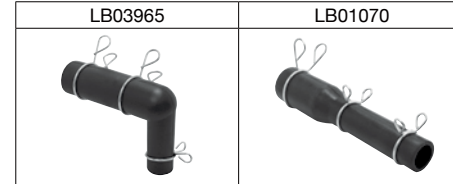

### Application Examples

#### Grease Trap

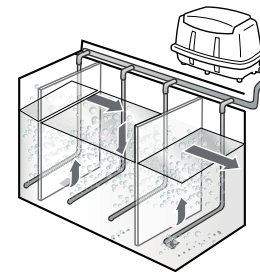

#### Home Aerobic Sewage Treatment System

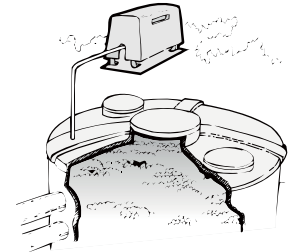

### External Dimensions (Unit: mm)

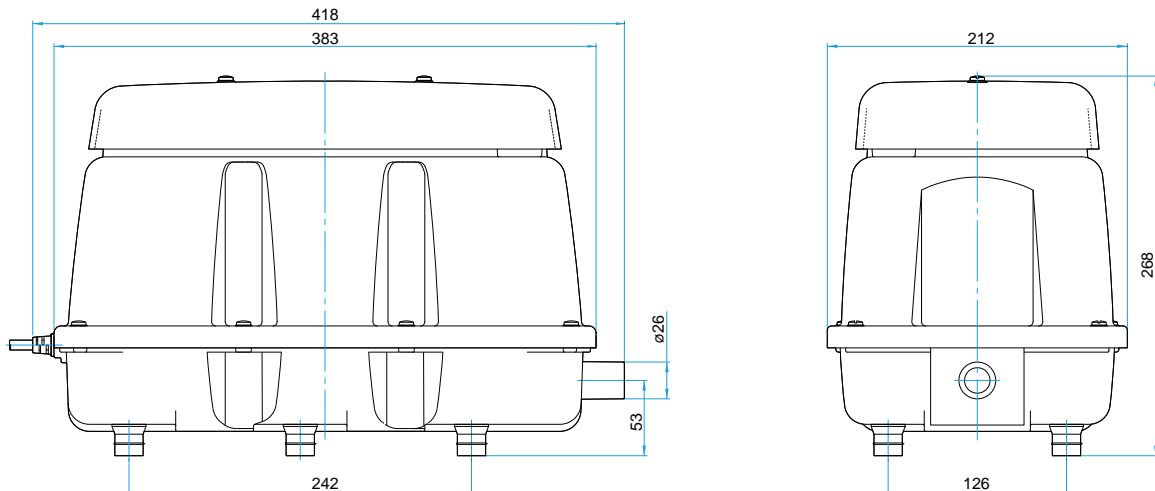

# Other product: Linicon (Vacuum Pump)

## Model LV-125A



Oil-less Compressor

- AC linear free piston vacuum pump
- Equipped with fuse and removable power cable
- Compact and lightweight
- Low noise level
- Oil-less construction

### Specifications

Rated Voltage	115 V AC	230 V AC
Power Consumption	14 W	15 W
Rated Frequency	60 Hz	50 Hz
Maximum Vacuum	-33.3 kPa (-250 mm Hg, -333 mbar, -9.84 in. Hg)	
Dimensions	135 (L) x 91 (W) x 146 (H) mm (5 - 5/16" x 3 - 37/64" x 5 - 3/4")	
Duty Cycle	Continuous	
Coil Insulation Class	B or its equivalent	E or its equivalent
Weight	1.5 kg (3.3 Lbs)	

### Vacuum Pick-Up Set

If the following options are prepared together with Model LV-125A, the Vacuum Pick-Up Set can be arranged.

- ① LB07629 Vacuum pen assembly
- ② LQ01267 Tube 3 x 5 x 2000
- ③ LA71242 Needle 1 x 1.5 x 40 (6 pcs/set)
- ④ LA71251 Pad 6 mm dia.
- ⑤ LA71249 Pad 4 mm dia.
- ⑥ LA71143 Pen stand

The needle can be bent in accordance with applications.

\*LA71069 P-100 includes ① - ⑥



### High Adsorption Power

In the case that the depth of vacuum is -33.3 kPa (-250 mmHg) and the surface to be vacuumed is flat.

Pad Diameter	A Suction power when the adsorption face is placed horizontally and moved upward.	B Suction power when the adsorption face is placed vertically and moved laterally.
4 mm	20 g	10 g
6 mm	50 g	25 g

Adsorption power:  $W (g) = D^2 \times 7.85 \times 250 / 736$

A is calculated by multiplying the safety rate of 0.5 to the above equation, and then rounded.



B is calculated by multiplying the safety rate of 0.25 to the above equation, and then rounded.

### Application Examples

Transferring spherical objects such as balls



Assembling precision parts

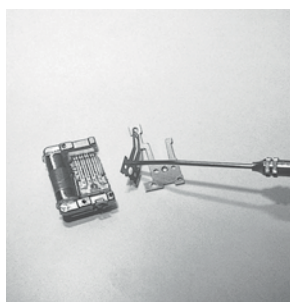

Moving tiny parts



Transferring uneven parts



Most suitable for handling electronic parts such as ICs and LSIs. Also small parts, micro parts such as those in watches and chemicals.

MADE TO ORDER

# MADE TO ORDER

## Compressor

AC0210	—	101
AC0610A	—	102

## Vacuum Pump

VP0645	—	103
VP0945	—	104
VP0925A	—	105
VP0660 x 2	—	106

## Diaphragm Pump

VCK0120	VacuumPump Type	—	107
VC0101E	Dual Type	—	108
VC0101E	Blower Type	—	109
VC0101S	Dual Type	—	110

## Blower

LAM-150	—	111
---------	---	-----

## Piezoelectric Pump

Made to order model	—	112
---------------------	---	-----

Page

# Compressor

## Model **AC0210**

Made to order



### Airflow & Power Consumption

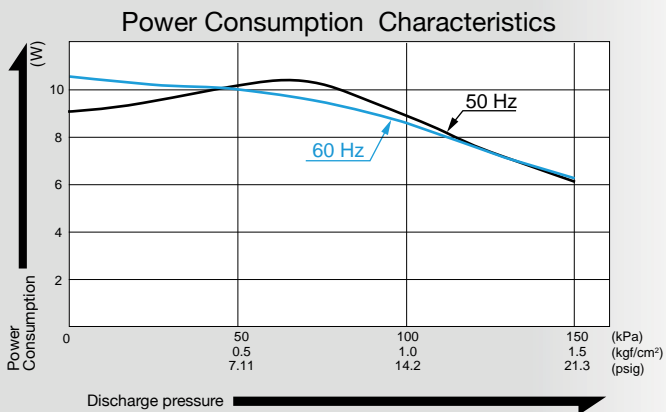
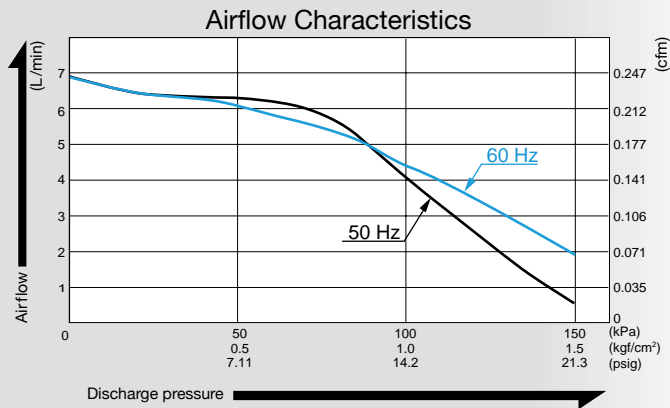

### Specifications

Rated Pressure	100 kPa (1.0 kgf/cm <sup>2</sup> ) 1.0 bar 14.2 psig	
Rated Airflow	3.5 L/min 0.124 cfm	
Maximum Pressure	120 kPa (1.2 kgf/cm <sup>2</sup> ) 1.2 bar 17.1 psig	
Rated Voltage	115 V AC	230 V AC
Power Consumption	23 W	24 W
Rated Frequency	60 Hz	50 Hz
Rated Performance	5,000 hours	
Outlet	4.7 mm O.D. hose barb	
Duty Cycle	Continuous	
Coil Insulation Class	E or its equivalent and B for UL	
Mounting Dimensions	76 (L) x 88 (W) mm 2 - 63/64" (L) x 3 - 15/32" (W)	
Weight	1.7 kg 3.7 Lbs	
Leadwire Length	300 mm 11 - 13/16"	

### Application Examples

**Air Bearing for Precision Machines**

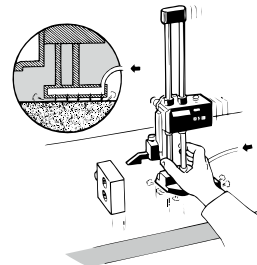

**Nebulizer**

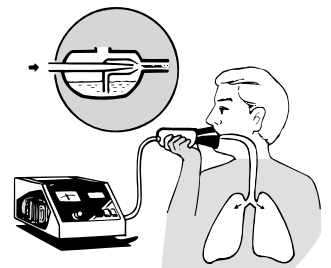

### External Dimensions (Unit: mm)

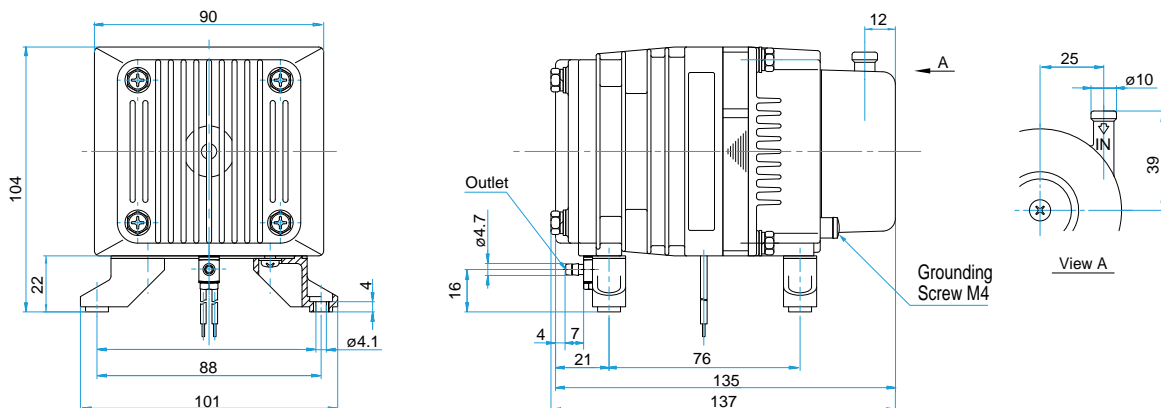

# Compressor

## Model **AC0610A**

Made to order

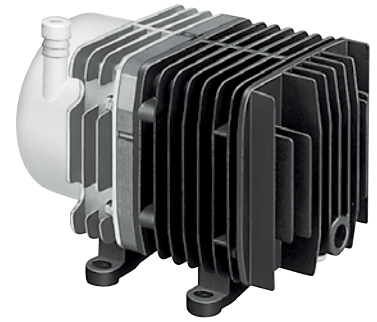

### Airflow & Power Consumption

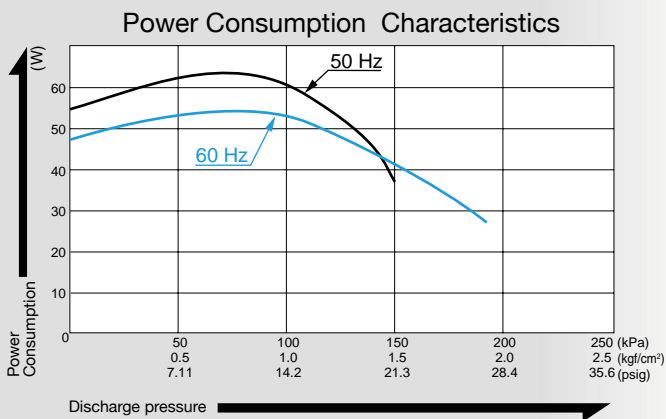
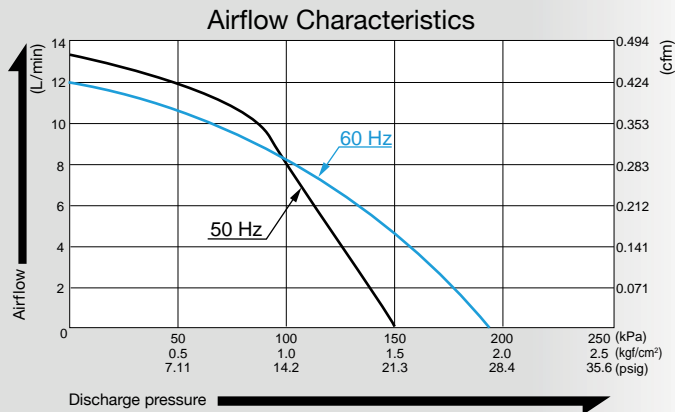

### Specifications

Rated Pressure	100 kPa (1.0 kgf/cm <sup>2</sup> ) 1.0 bar 14.2 psig	
Rated Airflow	8 L/min 0.283 cfm	
Maximum Pressure	150 kPa (1.5 kgf/cm <sup>2</sup> ) 1.5 bar 21.3 psig	
Rated Voltage	115 V AC	230 V AC
Power Consumption	52 W	60 W
Rated Frequency	60 Hz	50 Hz
Rated Performance	10,000 hours	
Outlet	ISO Rc 1/4	
Duty Cycle	Continuous	
Coil Insulation Class	F or its equivalent	
Mounting Dimensions	68 (L) x 84 (W) mm 2 - 43/64" (L) x 3 - 5/16" (W)	
Weight	3.2 kg 7.1 Lbs	
Leadwire Length	200 mm 7 - 7/8"	

### Application Examples

#### Dispenser

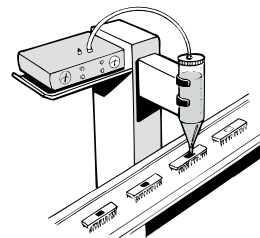

#### Automatic Stamper

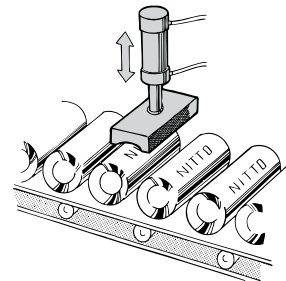

### External Dimensions (Unit: mm)

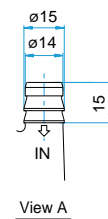
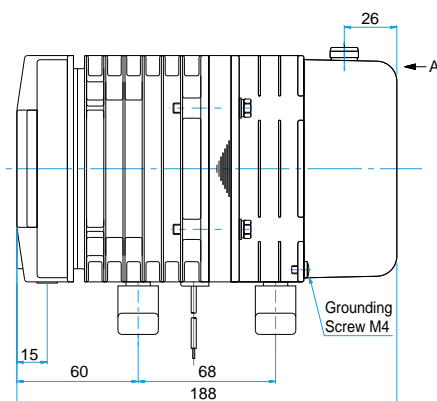
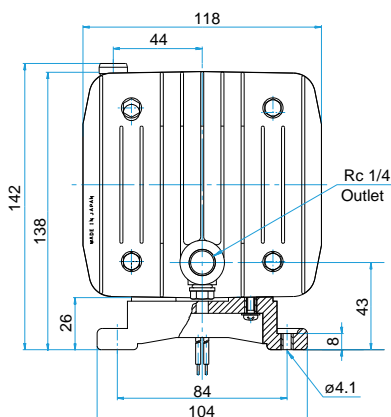

# Vacuum Pump

## Model VPO645

Made to order

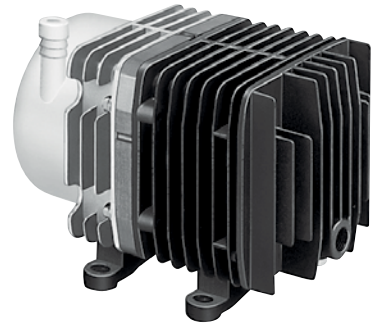

### Airflow & Power Consumption

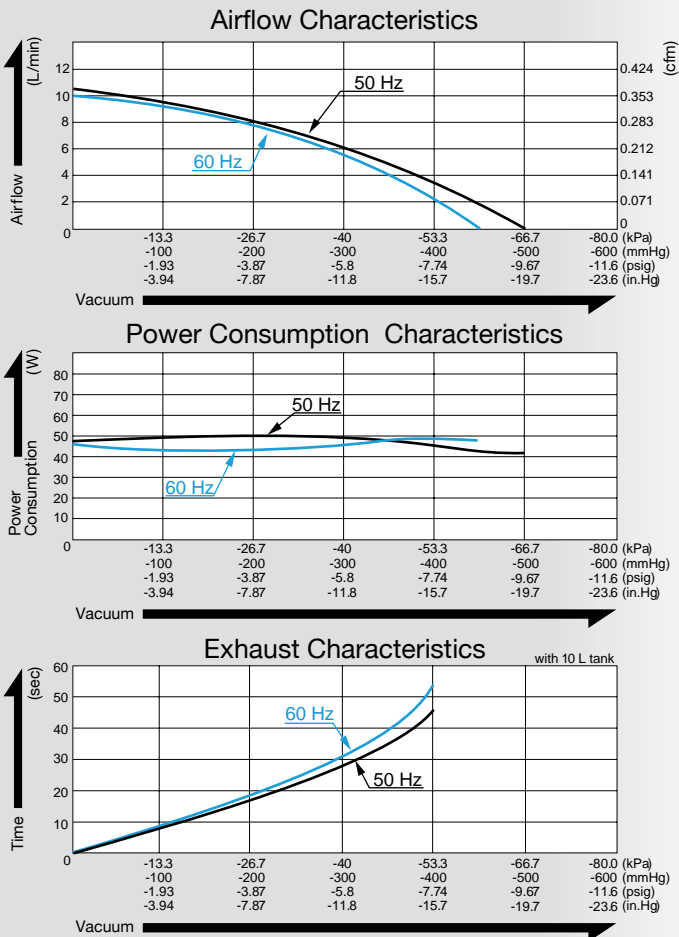

### Specifications

Attainable Vacuum *1	-60 kPa (-450 mmHg) -600 mbar -17.7 in. Hg	
Free Air Displacement	10 L/min 0.35 cfm	
Rated Voltage	115 V AC	230 V AC
Power Consumption	48 W	50 W
Rated Frequency	60 Hz	50 Hz
Rated Performance	3,000 hours	
Inlet	15 mm O.D. hose barb	
Outlet	ISO Rc 1/4	
Duty Cycle	Continuous	
Coil Insulation Class	E or its equivalent	
Mounting Dimensions	68 (L) x 84 (W) mm 2 - 43/64" (L) x 3 - 5/16" (W)	
Weight	3.2 kg 7.1 Lbs	
Leadwire Length	200 mm 7 - 7/8"	

\*1: Operations at higher than -60 kPa need an additional leak valve or relief valve on the inlet piping.

### Application Examples

#### Liquid Purification

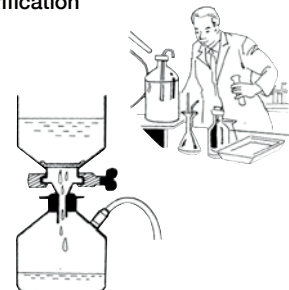

### External Dimensions (Unit: mm)

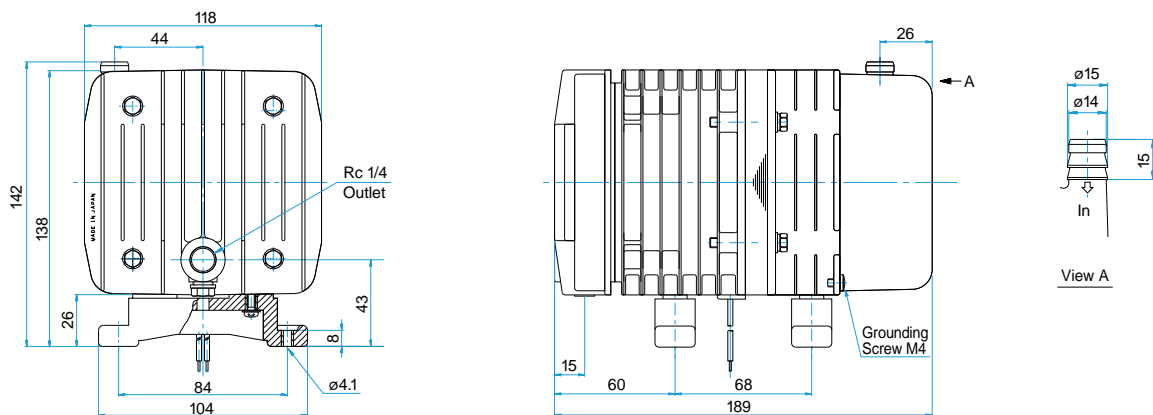



# Vacuum Pump

## Model VP0945

Made to order

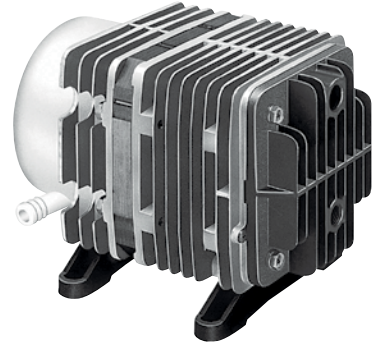

### Airflow & Power Consumption

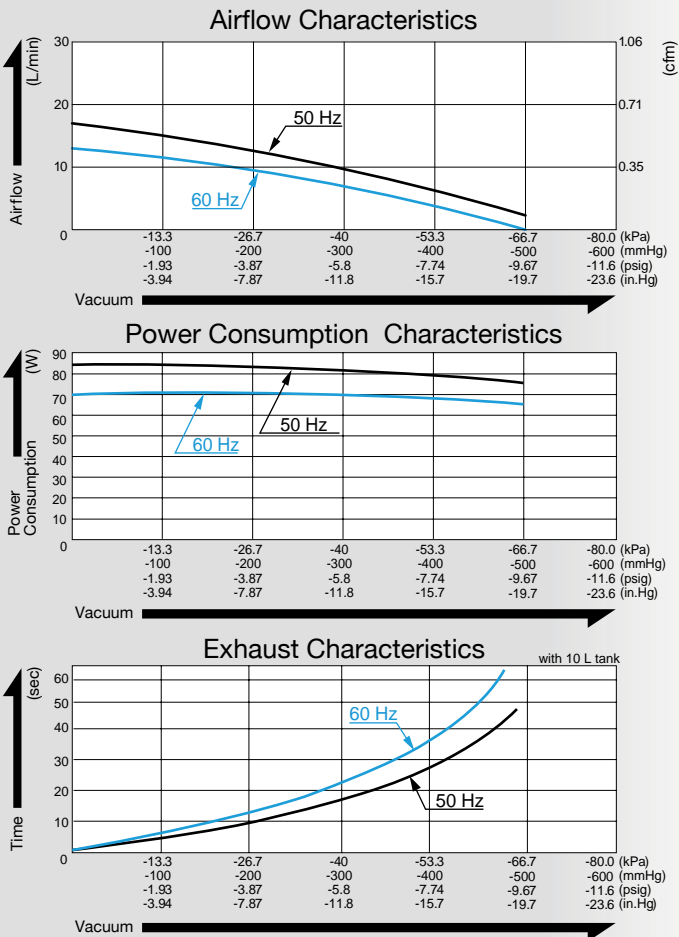

### Specifications

Attainable Vacuum *1	-60 kPa (-450 mmHg) -600 mbar -17.7 in. Hg	
Free Air Displacement	12 L/min 0.42 cfm	
Rated Voltage	115 V AC	230 V AC
Power Consumption	70 W	85 W
Rated Frequency	60 Hz	50 Hz
Rated Performance	3,000 hours	
Inlet	15 mm O.D. hose barb	
Outlet	ISO Rc 1/4	
Duty Cycle	Continuous	
Coil Insulation Class	E or its equivalent	
Mounting Dimensions	102 (L) x 130 (W) mm 4 - 1/64" (L) x 5 - 1/8" (W)	
Weight	4.9 kg 10.8 Lbs	
Leadwire Length	300 mm 11 - 13/16"	320 mm 12 - 19/32"

\*1: Operations at higher than -60 kPa need an additional leak valve or relief valve on the inlet piping.

### Application Examples

#### Vacuum Vice

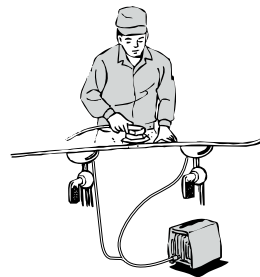

#### Impregnation Depressurizer

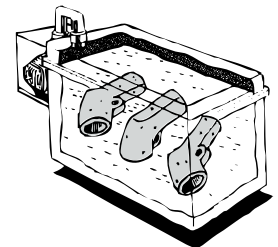

### External Dimensions (Unit: mm)

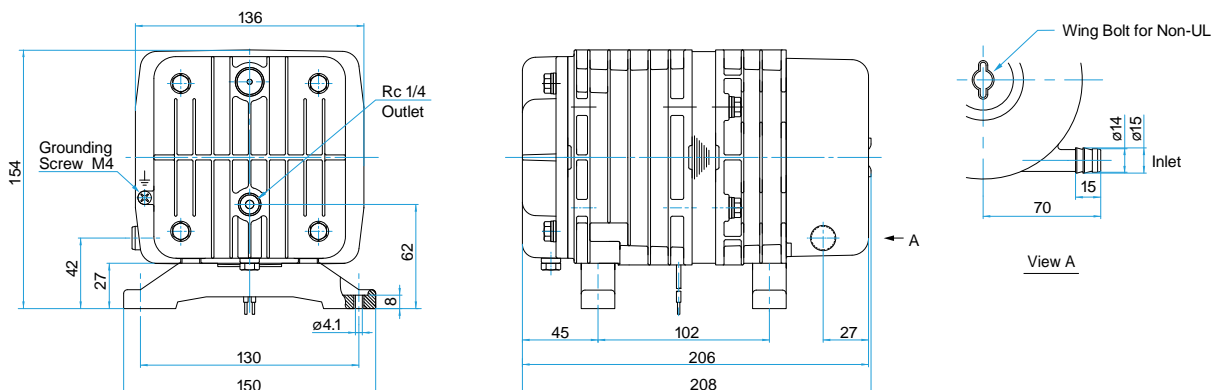

# Vacuum Pump

## Model VP0925A

Made to order

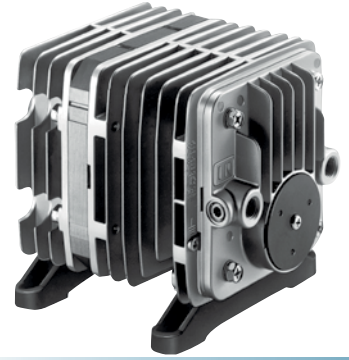

### Airflow & Power Consumption

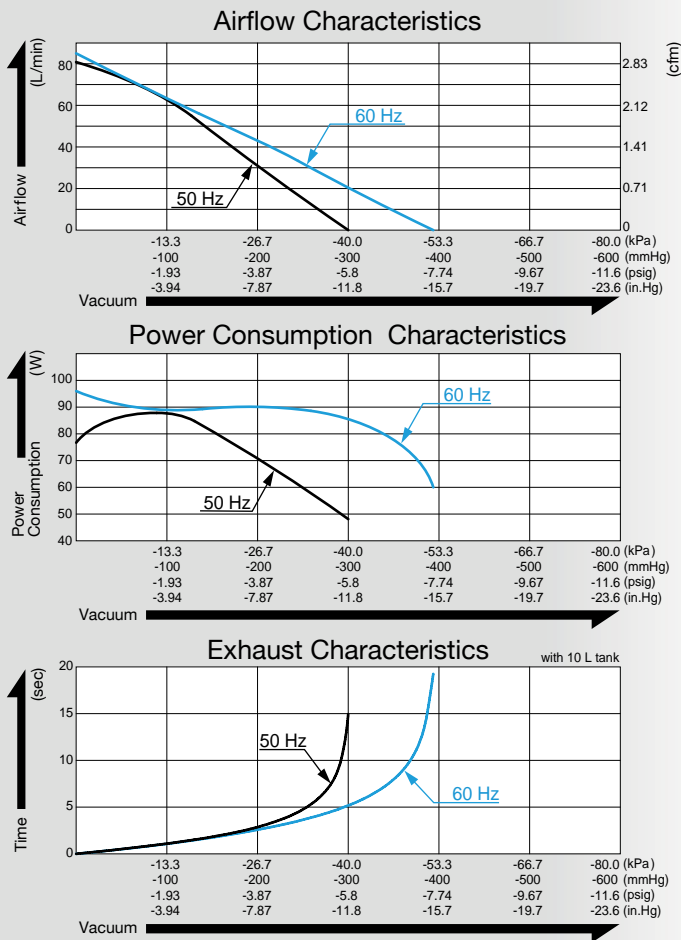

### Specifications

Attainable Vacuum *1	-33.3 kPa (-250 mmHg) -333 mbar -9.84 in. Hg	
Free Air Displacement	80 L/min 2.83 cfm	
Rated Voltage	115 V AC	230 V AC
Power Consumption	95 W	88 W
Rated Frequency	60 Hz	50 Hz
Rated Performance	10,000 hours	
Inlet	ISO Rc 1/4	
Outlet	ISO Rc 1/4	
Duty Cycle	Continuous	
Coil Insulation Class	B or its equivalent	
Mounting Dimensions	102 (L) x 130 (W) mm 4 - 1/64" (L) x 5 - 1/8" (W)	
Weight	4.5 kg 9.9 Lbs	
Leadwire Length	300 mm 11 - 13/16"	320 mm 12 - 19/32"

\*1: Operations at higher than -33.3 kPa need an additional leak valve or relief valve on the inlet piping.

### Application Examples

#### Microfiche Camera

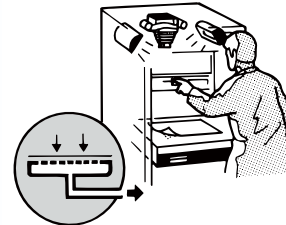

#### Vacuum Material Handling Equipment

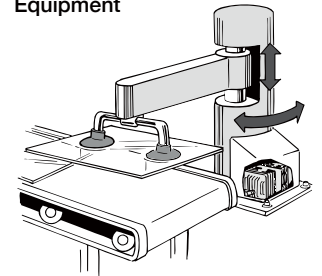

### External Dimensions (Unit: mm)

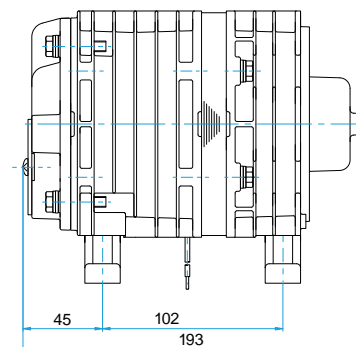
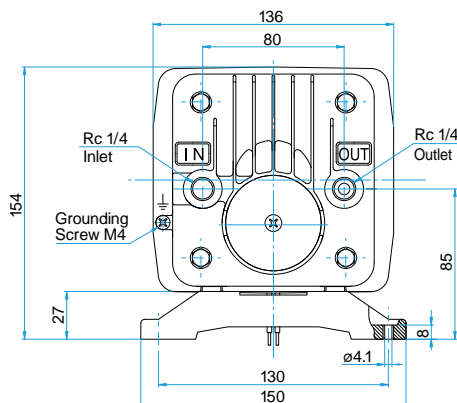

# Vacuum Pump

## Model VPO660x2

Made to order

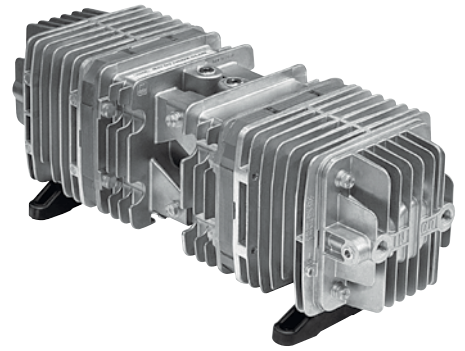

### Airflow & Power Consumption

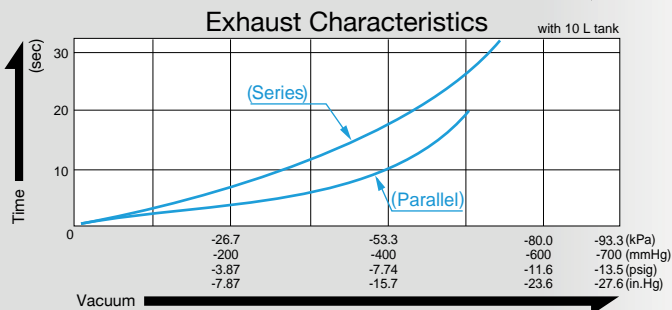
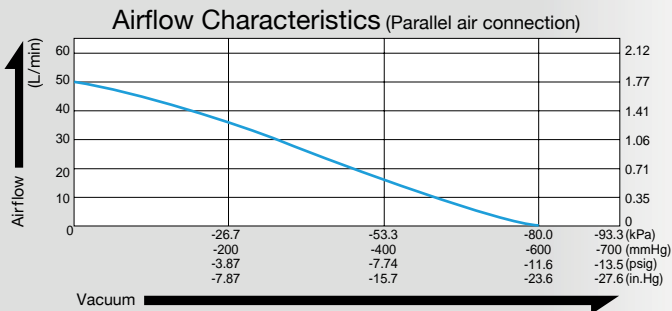
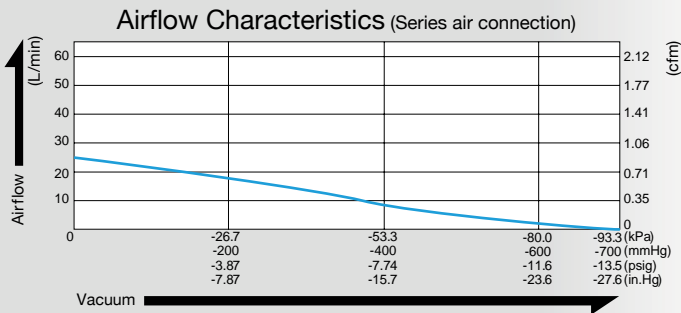

### Specifications

Attainable Vacuum *1	Series Connection	-93.3 kPa (-700 mmHg) -933 mbar -27.6 in. Hg	Parallel Connection	-80 kPa (-600 mmHg) -800 mbar -23.6 in. Hg
Free Air Displacement		25 L/min 0.88 cfm		50 L/min 1.77 cfm
Rated Performance	6,000 hours			
Rated Voltage	115 V AC		230 V AC	
Power Consumption	125 W		100 W	
Rated Frequency	60 Hz		50 Hz	
Inlet	ISO Rc 1/4, 2 ports			
Outlet	ISO Rc 1/4, 2 ports			
Duty Cycle	Continuous			
Coil Insulation Class	B or its equivalent			
Mounting Dimensions	280 (L) x 130 (W) mm 11 - 1/32" (L) x 5 - 1/8" (W)			
Weight	10 kg 22 Lbs			
Leadwire Length	150 mm 5 - 7/8"		600 mm 23 - 5/8"	

\*1: Operations at higher than -93.3 kPa in series or -80 kPa in parallel need an additional leak valve or relief valve on the inlet piping.

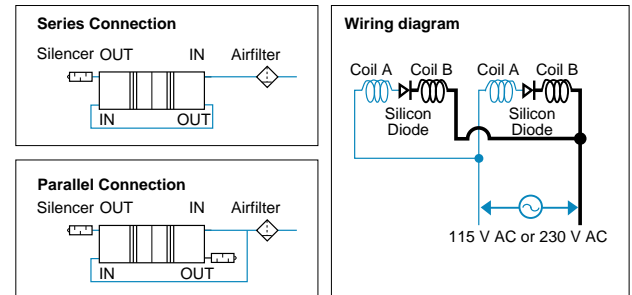

\* Air line connection is required by the user.

### External Dimensions (Unit: mm)

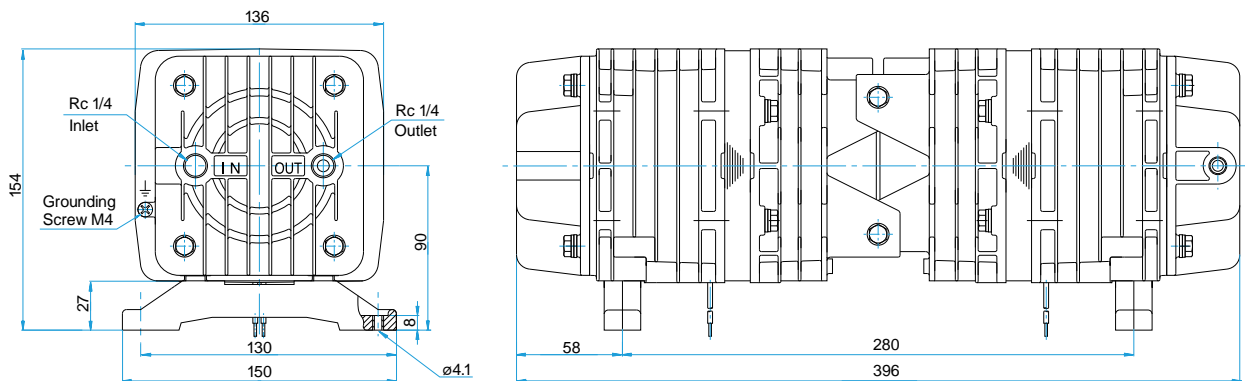

# Vacuum Pump

## Model VCK0120

Made to order



\*Internal image

### Airflow & Power Consumption

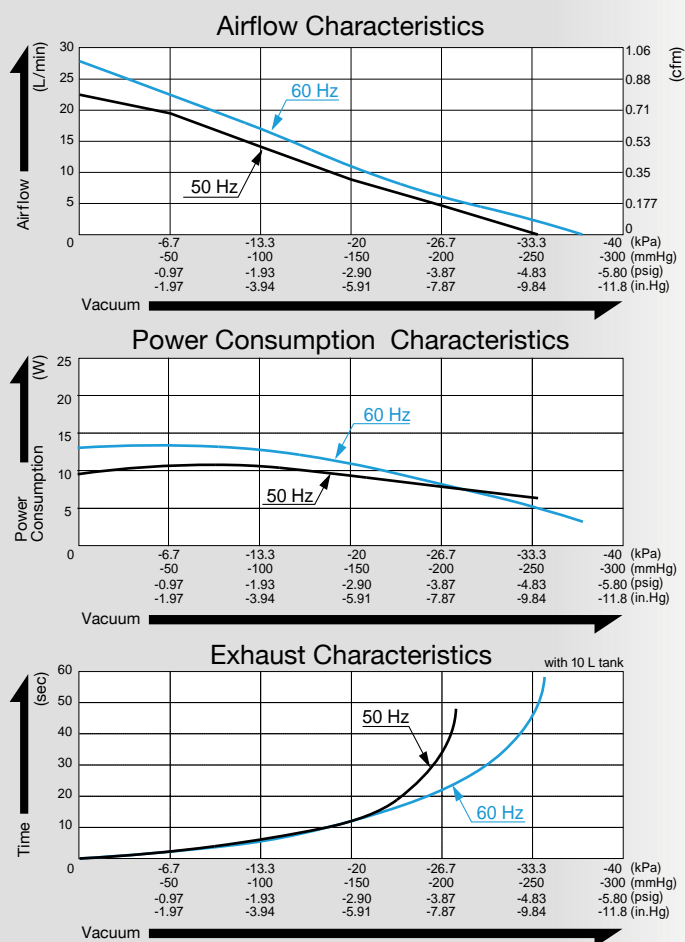

### Specifications

Attainable Vacuum	-26.7 kPa (-200 mmHg) - 267 mbar - 7.87 in.Hg	
Free Air Displacement	18 L/min 0.64 cfm	
Rated Voltage	120 V AC	230 V AC
Power Consumption	14 W	11 W
Rated Frequency	60 Hz	50 Hz
Rated Performance	5,000 hours	
Inlet	ISO Rc 1/8	
Outlet	ISO Rc 1/8	
Duty Cycle	Continuous	
Coil Insulation Class	B or its equivalent	
Mounting Dimensions	152 (L) x 128 (W) mm 5 - 63/64" (L) x 5 - 3/64" (W)	
Weight	1.9 kg 4.2 Lbs	
Leadwire Length	300 mm 11 - 13/16"	

### Application Examples

#### Medical Cup Suction

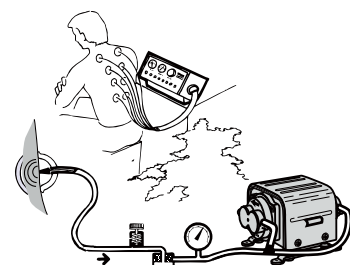

### External Dimensions (Unit: mm)

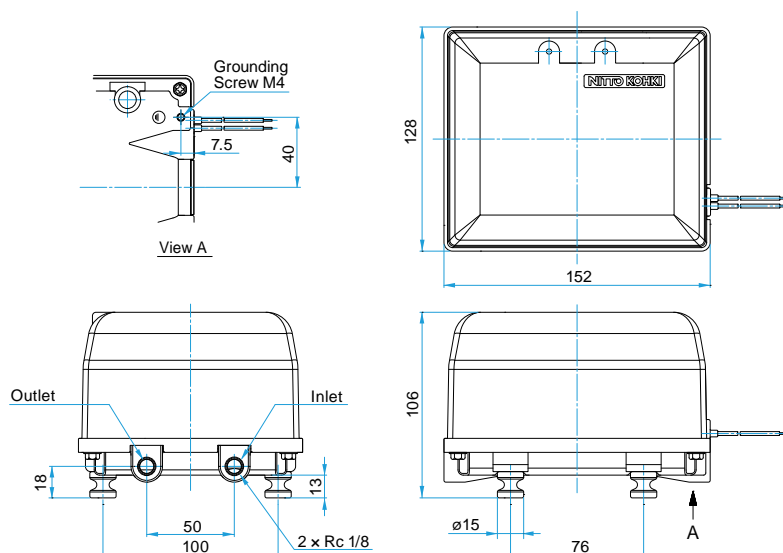

# Compressor and Vacuum Pump

## Model VC0101E

Made to order

Dual Type

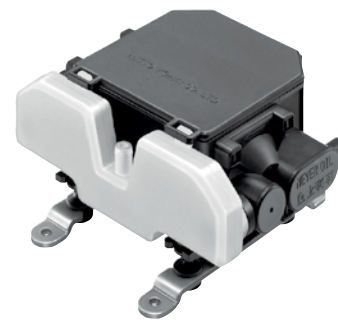

### Airflow & Power Consumption

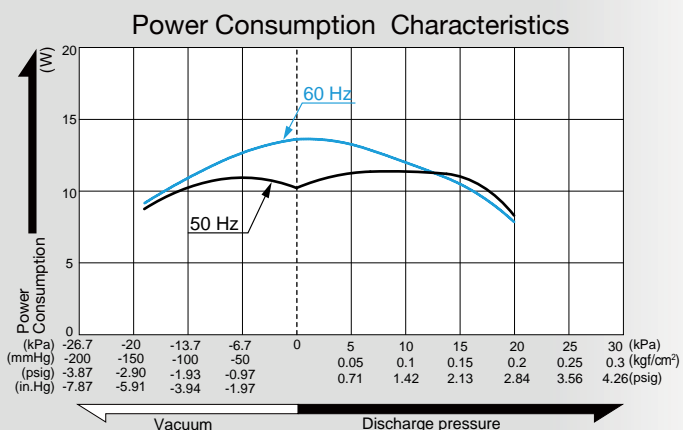
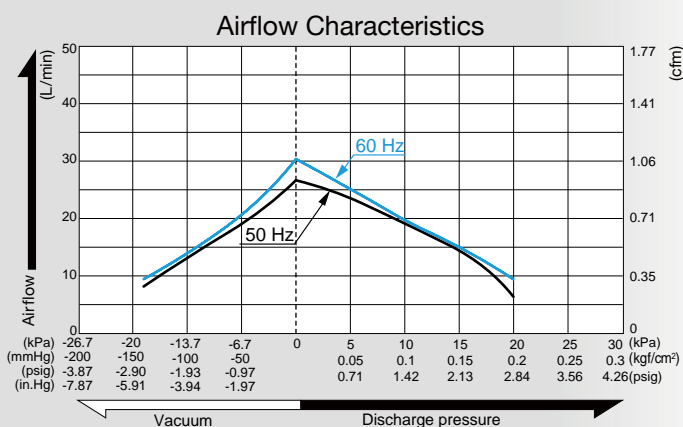

### Specifications

Rated Pressure	10 kPa (0.1 kgf/cm <sup>2</sup> ) 0.1 bar 1.42 psig	
Rated Airflow	15 L/min 0.53 cfm	
Maximum Pressure	20 kPa (0.2 kgf/cm <sup>2</sup> ) 0.2 bar 2.84 psig	
Attainable Vacuum	-18.7 kPa (-140 mmHg) -186 mbar -5.51 in.Hg	
Rated Voltage	120 V AC	230 V AC
Power Consumption	11.5 W	
Rated Frequency	60 Hz	50 Hz
Rated Performance	5,000 hours	
Working Pressure Range	-18.7 kPa to 20 kPa (-140 mmHg to 0.2 kgf/cm <sup>2</sup> ) -187 mbar to 0.2 bar -5.51 in.Hg to 2.84 psig	
Inlet	7.5 mm O.D. hose barb	
Outlet	7.5 mm O.D. hose barb	
Duty Cycle	Continuous	
Coil Insulation Class	E or its equivalent	
Mounting Dimensions	66 (L) x 100 (W) mm 2 - 19/32" (L) x 3 - 15/16" (W)	
Weight	0.82 kg 1.81 Lbs	
Leadwire Length	300 mm 11 - 13/16"	

A UL approved model for 120 V is available upon request.

### Application Examples

Massage Devices

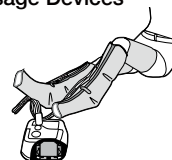

Bedsore Prevention Mattress



### External Dimensions (Unit: mm)

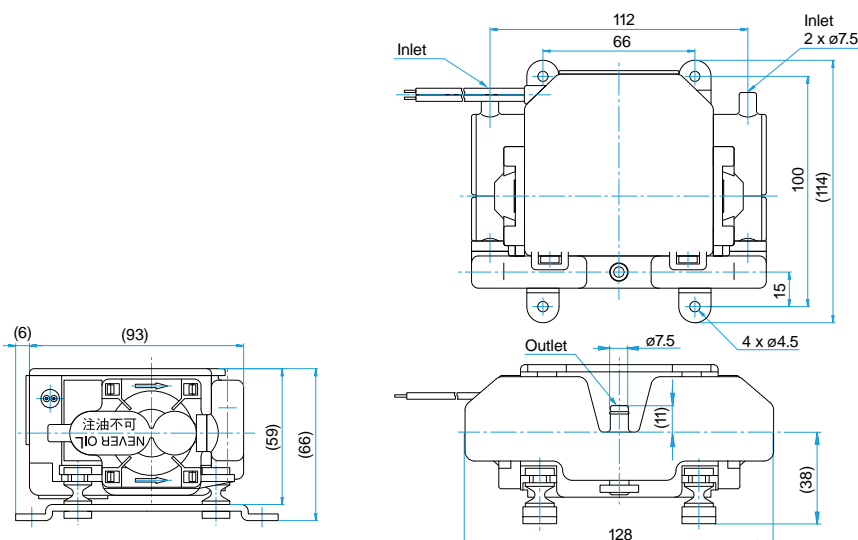

# Compressor

## Model VC0101E

Made to order

### Blower Type

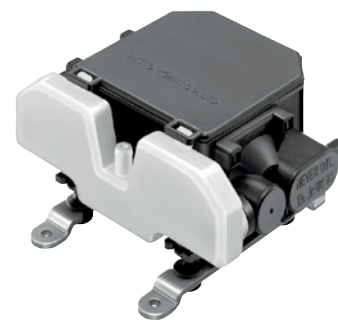

#### Airflow & Power Consumption

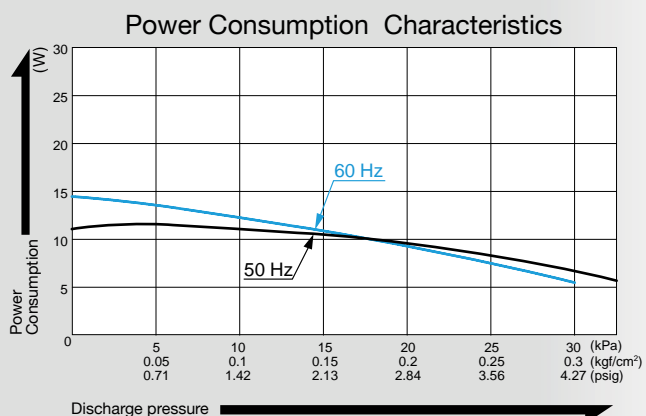
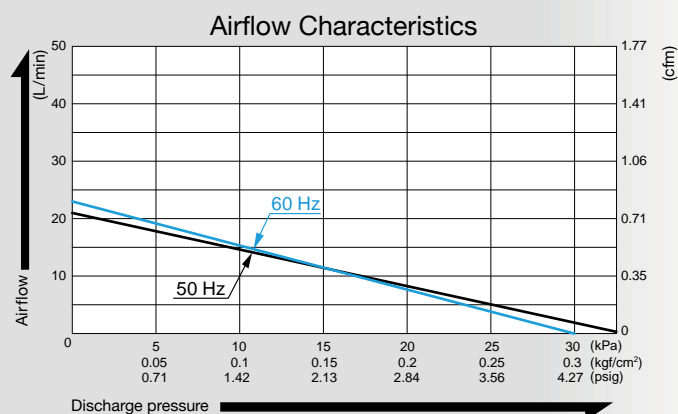

#### Specifications

Rated Pressure	10 kPa (0.1 kgf/cm <sup>2</sup> ) 0.1 bar 1.42 psig	
Rated Airflow	15 L/min 0.53 cfm	
Maximum Pressure	20 kPa (0.2 kgf/cm <sup>2</sup> ) 0.2 bar 2.84 psig	
Rated Voltage	120 V AC	230 V AC
Power Consumption	11.5 W	
Rated Frequency	60 Hz	50 Hz
Rated Performance	5,000 hours	
Working Pressure Range	0 to 20 kPa (0 to 0.2 kgf/cm <sup>2</sup> ) 0 to 0.2 bar 0 to 2.84 psig	
Outlet	7.5 mm O.D. hose barb	
Duty Cycle	Continuous	
Coil Insulation Class	E or its equivalent	
Mounting Dimensions	66 (L) x 100 (W) mm 2 - 19/32" (L) x 3 - 15/16" (W)	
Weight	0.82 kg 1.81 Lbs	
Leadwire Length	300 mm 11 - 13/16"	

A UL approved model for 120 V is available upon request.

#### Application Examples

Massage Devices

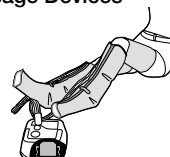

Bedsore Prevention Mattress



#### External Dimensions (Unit: mm)

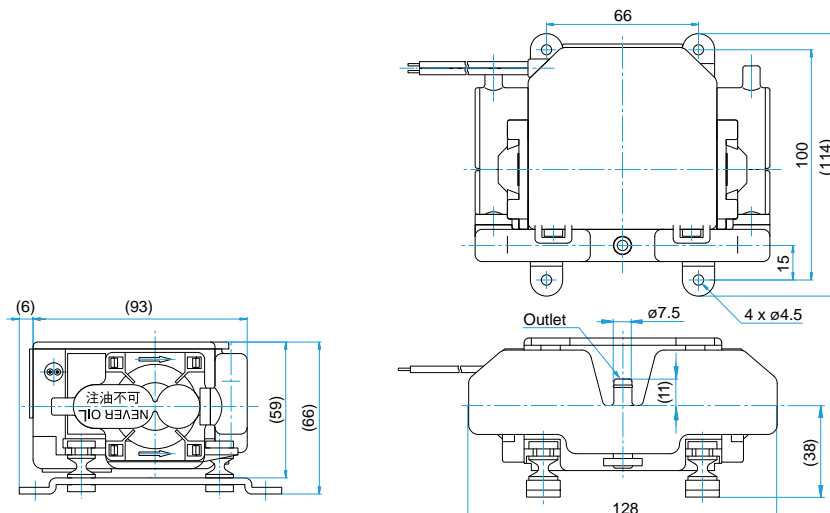

# Compressor and Vacuum Pump

## Model VC0101S

Made to order

Dual Type

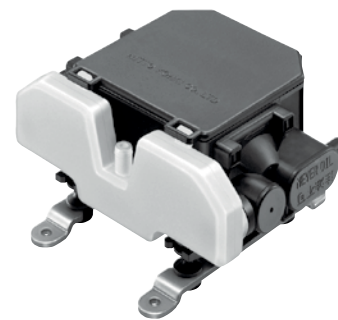

### Airflow & Power Consumption

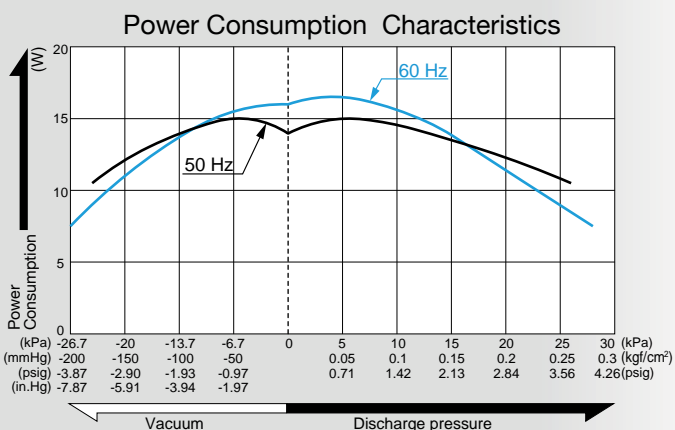
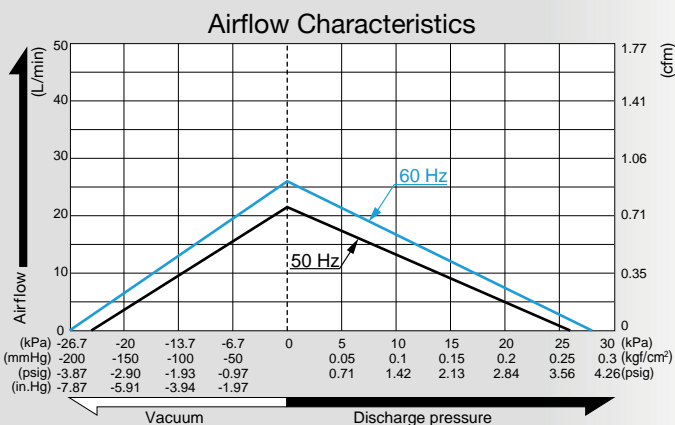

### Specifications

Rated Pressure	5 kPa (0.05 kgf/cm <sup>2</sup> ) 0.05 bar 0.71 psig	
Rated Airflow	15 L/min 0.53 cfm	
Maximum Pressure	26 kPa (0.26 kgf/cm <sup>2</sup> ) 0.26 bar 3.70 psig	
Attainable Vacuum	-24 kPa (-180 mmHg) -240 mbar -7.09 in.Hg	
Rated Voltage	120 V AC *1	230 V AC
Power Consumption	15 W	
Rated Frequency	60 Hz	50 Hz
Rated Performance	5,000 hours	
Working Pressure Range	-24 kPa to 26 kPa (-180 mmHg to 0.26 kgf/cm <sup>2</sup> ) -240 mbar to 0.26 bar -7.09 in.Hg to 3.70 psig	
Inlet	7.5 mm O.D. hose barb	
Outlet	7.5 mm O.D. hose barb	
Duty Cycle	60 minutes	
Coil Insulation Class	B or its equivalent	
Mounting Dimensions	66 (L) x 100 (W) mm 2 - 19/32" (L) x 3 - 15/16" (W)	
Weight	0.82 kg 1.81 Lbs	
Leadwire Length	300 mm 11 - 13/16"	

\*1: 120 V AC UL version is unavailable.

### Application Examples

Massage Devices

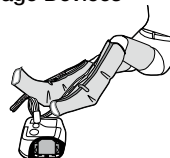

Bedsore Prevention Mattress



### External Dimensions (Unit: mm)

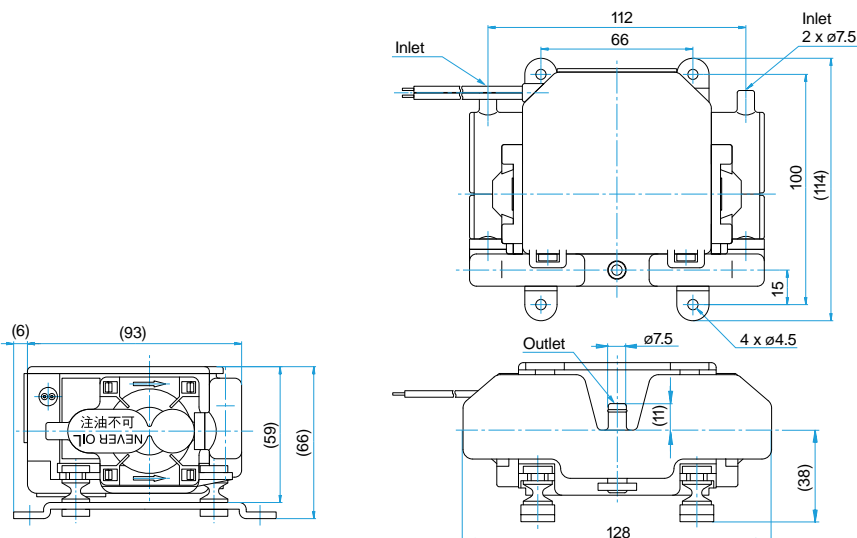

# Blower

## Model **LAM-150**

Made to order



### Airflow Characteristics

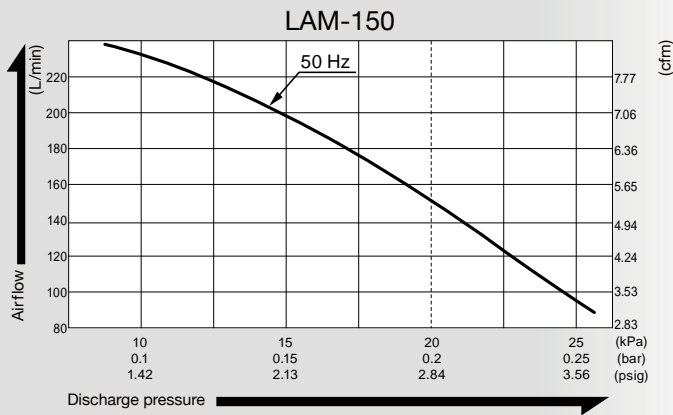

### Specifications

	LAM-150
Power Supply	230 V AC
Rated Frequency	50 Hz
Power Consumption	140 W
Rated Pressure	20 kPa (0.2 kgf/cm <sup>2</sup> ) 0.2 bar 2.84 psig
Rated Airflow	150 L/min 5.3 cfm
Weight	12.3 kg 27.1 Lbs

### Optional Hose Assemblies

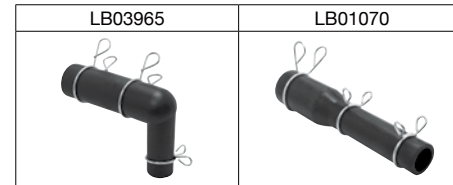

### Application Examples

#### Grease Trap

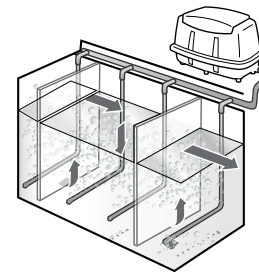

#### Home Aerobic Sewage Treatment System

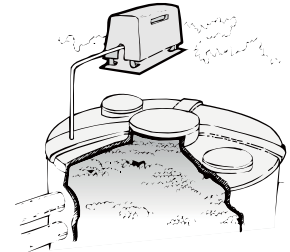

### External Dimensions (Unit: mm)

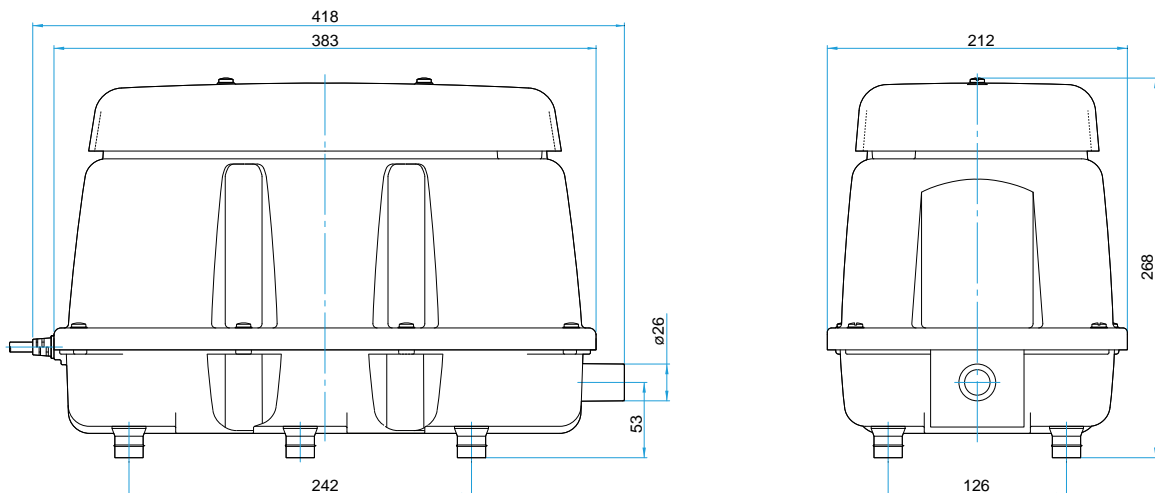



# Piezoelectric Pump

# BIMOR PUMP

Made to order

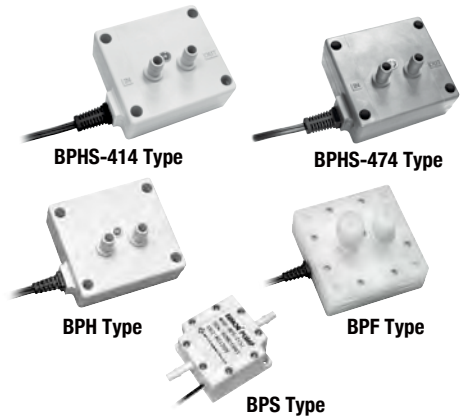

## Made to order model

These models are made-to-order models. Please send a request for quotation to your nearest distributor.

## Specifications

\*Please see page 85 for external dimensions.

Voltage(AC) — 120 V 60 Hz					Voltage(AC) — 240 V 60 Hz					Material of Wetted Parts			
Model	Current (mA)	Self-priming Pressure (kPa) <sup>*1</sup>	Flow Rate (mL/min) <sup>*1</sup>	Discharge Pressure (kPa)	Model	Current (mA)	Self-priming Pressure (kPa) <sup>*1</sup>	Flow Rate (mL/min) <sup>*1</sup>	Discharge Pressure (kPa)	Housing	Liquid Contact Sheet	Valve / O-ring	Weight (g)
—	—	—	—	—	BPS-215i	1.8	3	30	15	PP	PP	IIR	40
—	—	—	—	—	BPS-235G	1.8	1.5	30	15	POM	PTFE	FKM	40
BPH-214i	15	8	350	18	BPH-214i	7.5	8	350	18	PP	PP	IIR	130
—	—	—	—	—	BPH-214D	7.5	8	350	18	PP	PP	VMQ	130
—	—	—	—	—	BPH-414i	15	12	500	35	PP	PP	IIR	140
BPH-414D	30	12	500	35	BPH-414D	15	12	500	35	PP	PP	VMQ	140
—	—	—	—	—	BPH-414E	15	12	500	35	PP	PP	EPDM	140
BPH-414G	30	10	450	32	BPH-414G	15	10	450	32	PP	PTFE	FKM	140
BPH-474G	30	10	400	35	—	—	—	—	—	PPS	PTFE	FKM	170
BPH-474P	30	10	400	35	—	—	—	—	—	PPS	PTFE	FFKM/FEP	170
—	—	—	—	—	BPHS-414i	15	12	700	35	PP	PP	IIR	160
—	—	—	—	—	BPHS-414E	15	12	700	35	PP	PP	EPDM	160
—	—	—	—	—	BPHS-414G	15	12	700	35	PP	PTFE	FKM	160
—	—	—	—	—	BPHS-474G	15	10	500	35	PPS	PTFE	FKM	180
—	—	—	—	—	BPHS-474P	15	10	500	35	PPS	PTFE	FFKM/FEP	180
BPF-465P	30	10	400	35	BPF-465P	15	10	400	35	PFA	PTFE	FFKM/FEP	350

\*1: The values in the specification shows the performance obtained using 25°C of water at 60 Hz. When the pump is used at 50 Hz, the flow rate will decrease approximately 20%. When the liquid temperature is low, the check valve will harden. As a result, the flow rate and the self-priming pressure will decrease. Especially the flow rate of the pump with fluorine rubber will decrease by half at 5°C, so select with sufficient margin. Since the flow rate will decrease with highly viscous liquids, please check the flow rate with an actual pump before use.

Material Description	EPDM ..... Ethylene Propylene Rubber	IIR ..... Butyl Rubber	PPS ..... Polyphenylene Sulfide
	FEP ..... Fluoroethylene Propylene	PFA ..... Fluororesin (Perfluoroalkoxy)	PTFE ..... Tetrafluororesin (Polytetrafluoroethylene)
	FFKM ..... Perfluoroelastomer	POM ..... Polyacetal	VMQ ..... Dimethyl Silicon Rubber
	FKM ..... Fluorine Rubber	PP ..... Polypropylene	

## Suitable/unsuitable chemical liquids

Model	Examples of suitable chemical liquids	Examples of unsuitable chemical liquids
BPS-215i BPH-214i BPH-414i BPHS-414i	Ethanol, Dilute hydrochloric acid, Sodium carbonate, Benzaldehyde, Formalin	Xylene, Mineral oil, Carbon tetrachloride, Trichloroethylene, Toluene, Benzene
BPH-414E BPHS-414E	Ammonia water, Ethanol, Dilute hydrochloric acid, Caustic potash, Caustic soda, Methanol	Xylene, Mineral oil, Carbon tetrachloride, Trichloroethylene, Toluene, Benzene
BPS-235G	Ethanol, Xylene, Silicone oil, Kerosene, Toluene, Benzene	Ammonia water, Hydrochloric acid, Hydrogen peroxide, Sodium hypochlorite, Nitric acid, Sulfuric acid
BPH-214D BPH-414D	Ammonia water, Ethanol, Sodium hypochlorite, Methanol	Caustic soda, Carbon tetrachloride, Silicone oil, Trichloroethylene, Toluene, Benzene
BPH-414G BPHS-414G	Ethanol, Hydrogen peroxide, Mineral oil, Sodium hypochlorite	Acetone, Ammonia water, Glacial acetic acid, Hydrofluoric acid, Formalin
BPH-474G BPHS-474G	Ethanol, Xylene, Carbon tetrachloride, Silicone oil, Trichloroethylene	Acetone, Ammonia water, Chlorosulfonic acid, Glacial acetic acid, Hydrofluoric acid, Formalin
BPH-474P BPHS-474P	Ethanol, Chloroform, Glacial acetic acid, Benzene, Methyl ethyl ketone	Chlorosulfonic acid, Fluorine oil, CFC 112, CFC 113
BPF-465P	Ethanol, Aqua regia, Ozone, Carbon tetrachloride, Concentrated nitric acid, Concentrated sulfuric acid, Fuming sulfuric acid	Fluorine oil, CFC 112, CFC 113

\*This chart is for reference only. Please confirm under the operating conditions before use.

## Precautions for Compressors and Vacuum Pumps

<b>CAUTION</b> The unit must be incorporated into a device that has an appropriate case and wiring. Not doing so may cause a fire, electric shock or burns.		<b>WARNING</b> Do not let the unit draw in or discharge any gas other than air. This may cause an explosion, fire or electric shock.		Avoid drawing in water and splashing any water on the unit. Otherwise there is the risk of a short circuit causing a fire or electric shock.	
Do not use the unit with a power supply other than the voltage shown on the unit. Doing so may cause a fire or electric shock.	Do not install the unit in a completely enclosed case (box) without proper or adequate ventilation. This may cause a fire or electric shock.	Use the unit within the proposed ambient temperature range. Using it out of the range may cause a fire or electric shock.	Avoid any strong impact to the unit as this may reduce the performance and durability of the unit.		
Do not place combustible materials near the unit. This may cause a fire.	The grounding screw of the unit should be utilized, except when connected to a double insulation device. Not grounding the unit may result in a fire or electric shock.	The unit must be installed at a level higher than the water surface when it is used for bubbling. If the unit is installed at a level lower than the water surface, fluid may flow into the unit and cause an electric shock.	Units must not be modified. Modifications may cause a fire or electric shock.		
Do not pull, scratch, forcefully bend, twist or heat the lead wires. This may damage them and cause a fire or electric shock.	When incorporating the unit into a device, the lead wires from the unit should be connected securely to the wiring of the device by means of soldering, crimping or by the use of screws. Insufficient connections may cause a fire or electric shock.	The unit must not be disassembled or repaired by anyone other than a person who has received Nitto Kohki technical training. (Except in the case of filter and piston maintenance and inspection in accordance with the operation manual.) Otherwise it may result in a fire or electric shock.	Do not allow anything to be placed on or to fall onto the lead wires. This may damage them and cause a fire or electric shock.		
When drawing in air contaminated with moisture, powder, or dust, add an external device to the unit for removing them. If these contaminants are drawn in, it may cause an electric shock. *Only for vacuum pumps.					

## Precautions for Blowers

<b>CAUTION</b> Do not install the unit in a place where it may be soaked with water or covered with snow. This may cause an electric shock or fire.		<b>WARNING</b> Do not let the unit draw in or discharge any gas other than air. This may cause an explosion, fire or electric shock.			
Use a power supply equipped with a ground-fault interrupter and overcurrent breaker. Failure to do so may cause an electric shock or fire.	Do not use the unit in hot and humid conditions. This may cause an electric shock, breakdown or fire.	Always place the unit above water level. Failure to do so may result in an electric shock or breakdown.	Use a waterproof wall outlet to supply power to the unit. Failure to do so may cause an electric shock or fire.		
The power supply voltage must be limited to the individual unit specifications as stated on the nameplate or instruction manual. Failure to do so may cause an electric shock or fire.	Have a qualified electrician do the electrical work. Failure to do so may cause an electric shock or fire.	Never modify the unit. This may cause an electric shock, breakdown, or fire.	Do not use the unit with the outlet port closed or at free displacement. This may cause an electric shock, breakdown, or fire.		
Do not place anything near the unit (within about 50 cm). Doing so may cause an electric shock or fire.	Never touch the power plug with wet hands. This may cause an electric shock.	Insert the power plug securely into the innermost position. Failure to do so may cause an electric shock.	Do not put anything on the power cable. Doing so may cause a fire or electric shock.		
Always grasp the power plug to disconnect the unit from the socket. Pulling it out by the cord may cause an electric shock or breakdown.	Do not use the unit in a place where flammable materials, such as gasoline, thinner, lacquer, benzene, etc. are being used. This may cause a fire or explosion.	Check the power plug at least once a year for dirt and dust and clean if necessary. Failure to do so may result in an electric shock or fire.	The power plug must be disconnected before the air filter is cleaned or replaced. Failure to do so may cause an electric shock or accident.		
Any removed air filter must be replaced before the operation is resumed. Failure to do so may cause an electric shock or breakdown.	Never try to disassemble or repair the unit. This may cause an electric shock, breakdown, fire or injury. Any repairs must be done by an electrician authorized by Nitto distributors.		Do not cover the Blower with a box or the like without proper or adequate ventilation. Doing so may cause a breakdown or fire.		

## Precautions for DC-Motor Pumps

Connect the plus terminal (if there is no indication of the plus terminal, use the terminal with a red mark as the plus terminal,) or the red lead wire of the unit to the plus terminal of the DC power source. Reverse connection may cause a breakdown, malfunction, or reduced rated performance.

## Precautions for Liquid Pumps

<b>CAUTION</b> Avoid any liquid contaminated with solids such as debris or dust. If dust or debris sticks to the valve, the unit may not perform properly. When the intrusion of dust or debris is expected, be sure to place a filter on the inlet side of the unit.		<b>WARNING</b> Confirm the suitability of the liquid that passes through the unit before use. Failure to do so may cause a leak, explosion, fire or electric shock.			
Avoid any liquid that may crystallize. If crystals stick to the valve, the unit may not perform properly. A preliminary test on the unit with the liquid to be used is recommended.	The performance of the unit is measured with the pump in its proper mounting position, which is described in the user's manual. Different mounting positions or nozzle directions may result in different performances.		There may be a risk that even a slight liquid pressure can open the valve due to siphon phenomenon. Place the outlet port at a position higher than the water level in the supply tank, or install a check valve if necessary to prevent water from being siphoned into the pump.		

## When Using Compressors and Vacuum Pumps

Check with our distributor in advance if you plan to use the compressor/vacuum pump at free displacement (0 kPa), or the vacuum pump with inlet port closed, or the compressor at maximum pressure.

- As compressors and vacuum pumps employ a self-cooling system, if the units are used at more than the rated pressure, the duty cycle of some of the models will need to be shortened.
  - When wanting to increase the duty cycle, it is recommended to use a fan to cool the compressor.
  - Do not use the compressor near flammable liquid gas.
  - Do not use the compressor in the rain or in wet and damp places.
  - Do not allow the pump to draw in corrosive gas.

- Be sure to install and use the compressor at a position higher than water level.

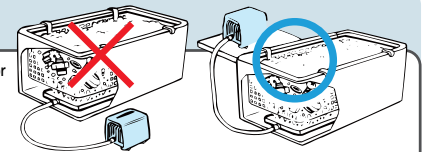

## Handling Problems

In any of the below cases, stop operation immediately, switch off the power and disconnect the unit from the power supply. Ask our distributor for repair.

- When oil such as a lubricant has been applied to the unit in error.
- When liquid such as water has entered into the unit by mistake.
- When the unit has suffered a severe impact such as being dropped.
- When an abnormal operation is observed, such as the emission of smoke, or an unusual smell or noise.

## Precautions for Pumps with Brush Motor

As operational time is increased, the value of insulation resistance becomes lower than that of the initial insulation resistance. If the outer surface of motor and the grounding of the power source are connected, do a preliminary check to assure no issues occur.

## Our Product Warranty

Our Products are covered by a limited warranty ("Warranty") under the following conditions.

- Duration: depends on individual products and their specifications
- Service: repair or replacement at our option  
Please be aware that a warranty claim will not be reimbursed with a cash payment.
- Object Person: original purchaser from our designated distributors

### 4. Out of Warranty

The following conditions are not covered by Warranty

- purchaser improperly used our products.
- purchaser did not comply with specifications and instructions stipulated in this Catalog when using our products, or
- purchaser did not comply with Caution for Safety stipulated in this Catalog when using our products, or
- repairing of our products was done by someone other than us, or
- We are not able to anticipate or predict such defects or causes of failure based on general technical knowledge of the specific application before or at the time of shipment, or
- defects are caused by the force majeure or other situations not attributable to us, or
- defects are not clearly attributable to us and
- defects are not about design, material or workmanship.

## Limitation of Liability

We, including designated distributors, will not be liable for any special damages or consequential damages and will not have any monetary liability to purchasers.

## PLASTIC CUPLA BC Type Valveless

For low pressure air piping

Working pressure	Valve structure	Applicable fluid
0.07 MPa (0.7 kgf/cm <sup>2</sup> )	Straight through	Air



- To connect, just push the plug into the socket.
- Plastic makes this ideal for use in environment prone to rusting.
- Compact and light weight for easy handling.
- Valveless construction gives more stable flow.

## CUBE CUPLA

Small and lightweight coupling for air supply lines to medical and/or scientific equipment

Working pressure	Valve structure	Applicable fluids
0.07 MPa (0.7 kgf/cm <sup>2</sup> )	Two-way shut-off, One-way shut-off, Straight through	Air, Water

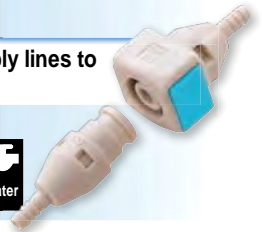

- Ultra-lightweight, made of polyacetal resin. Compact design for space saving.
- Just push plug into socket for connection. Simply press the button on the socket for disconnection.
- Both socket and plug have built-in valve types and valveless types. Valveless structure suits high viscosity fluids.
- Suitable for a wide range of applications from medical/scientific equipment to beverage machines or semiconductor manufacturing devices.

## MICRO CUPLA

For piping in pneumatic control devices

Working pressure	Valve structure	Applicable fluids
1.0 MPa (10 kgf/cm <sup>2</sup> )	One-way shut-off	Air, Water

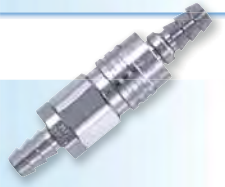

- Even though the valve is built in the socket, the sleeve outer diameter is confined to 9.5 mm.
- Compact design for piping in narrow spaces.
- Push-to-connect operation. Tube Fitter type for even easier tube insertion.
- Plated brass and stainless bodies are available for excellent corrosion resistance.
- Available in various end configurations to satisfy a wide range of pneumatic applications.

## SMALL CUPLA

Lightweight and compact for use on air lines and scientific equipment

Working pressure	Valve structure	Applicable fluids
0.7 MPa (7 kgf/cm <sup>2</sup> )	One-way shut-off	Air, Water



- Compact socket with built-in valve and 14 mm OD sleeve.
- Just push in the plug to the socket for connection.
- Also available with quick connect/disconnect Tube Fitter type.
- Chrome-plated brass for corrosion resistance adopted for the body.
- Available in various end configurations to satisfy a wide range of pneumatic applications.

## SUPER CUPLA

Light, compact for air piping connections

Working pressure	Valve structure	Applicable fluid
1.0 MPa (10 kgf/cm <sup>2</sup> )	One-way shut-off	Air



- Lightweight design suits direct connection to power tools.
- Push-to-connect for easy operation.
- Also available with quick connect/disconnect Tube Fitter type.
- Chrome-plated steel for corrosion resistance adopted for the body. (Partly aluminum)
- Available in various end configurations for a wide range of pneumatic applications.

## HI CUPLA 200

Push-to-connect type for air lines

Working pressure	Valve structure	Applicable fluid
1.5 MPa (15 kgf/cm <sup>2</sup> )	One-way shut-off	Air



- Just push the plug into the socket for simple and secure connection.
- New valve design for low pressure loss to achieve flow rate increase (15% up over the conventional model).
- End-face seal is achieved when connected.
- Enhanced operability with low connection resistance.
- End-face seal design is superior to external seal with an O-ring due to no seal damage caused by exhausted lubrication.
- Also available with quick connect/disconnect Tube Fitter type.

## HI CUPLA

Universal purpose couplings for air lines

Working pressure	Valve structure	Applicable fluids
1.5 MPa (15 kgf/cm <sup>2</sup> )	One-way shut-off	Air, Water (Steel applies to air only)



- An excellent general purpose coupling for connecting factory air supply to pneumatic tools.
- Steel CUPLA is suitable for air. Brass or stainless steel is suitable for water.
- Critical structural parts of steel models are heat-treated for increased strength giving greater durability and resistance to wear.
- Available in various body materials, sizes and end configurations applicable to a wide range of applications.

## HI CUPLA ACE

Lightweight plastic coupling with automatic safety lock for air line applications

Working pressure	Valve structure	Applicable fluids
1.5 MPa (15 kgf/cm <sup>2</sup> )	One-way shut-off	Air, Water



- Pressure ratings comparable to steel CUPLA.
- A built in "automatic lock mechanism" locks the sleeve upon connection, thus prevents accidental disconnection.
- Just push plug into socket for simple connection.
- The weight is a quarter of steel HI CUPLA for easy handling.
- Can be used for air and water.

# Air Compressor, Vacuum Pump & Liquid Pump



Japanese

[www.nitto-kohki.co.jp/network/jp/](http://www.nitto-kohki.co.jp/network/jp/)



Vietnam

[www.nitto-kohki.co.jp/network/vi/](http://www.nitto-kohki.co.jp/network/vi/)



English

[www.nitto-kohki.co.jp/network/](http://www.nitto-kohki.co.jp/network/)



Indonesia

[www.nitto-kohki.co.jp/network/id/](http://www.nitto-kohki.co.jp/network/id/)



Thai

[www.nitto-kohki.co.jp/network/th/](http://www.nitto-kohki.co.jp/network/th/)



Espanyol

[www.nitto-kohki.co.jp/network/es/](http://www.nitto-kohki.co.jp/network/es/)



YouTube

[www.youtube.com/c/NittoKohkiGLOBAL](http://www.youtube.com/c/NittoKohkiGLOBAL)



eCatalog

[www.nitto-kohki.co.jp/e/prd/d\\_cat/](http://www.nitto-kohki.co.jp/e/prd/d_cat/)

## NITTO KOHKI CO., LTD.

### Head Office

9-4, Nakaikagami 2-chome, Ohta-ku, Tokyo 146-8555, Japan

Tel : +81-3-3755-1111 Fax : +81-3-3753-8791 E-mail : [overseas@nitto-kohki.co.jp](mailto:overseas@nitto-kohki.co.jp)

Web [www.nitto-kohki.co.jp/e/](http://www.nitto-kohki.co.jp/e/)



ISO9001  
JQA-2025  
ISO14001  
JQA-EM4057  
H.Q./R&D Lab

### Overseas Affiliates / Offices

#### NITTO KOHKI U.S.A., INC.

46 Chancellor Drive, Roselle, Illinois 60172, U.S.A.

For Pump

Tel : +1-630-924-8811 Fax : +1-630-924-0808

For CUPLA

Tel : +1-630-924-5959 Fax : +1-630-924-1174

For Tool

Tel : +1-630-924-9393 Fax : +1-630-924-0303

[www.nittokohki.com/](http://www.nittokohki.com/)

#### NITTO KOHKI EUROPE GMBH

Gottlieb-Daimler-Str. 10, 71144 Steinenbronn, Germany

Tel : +49-7157-989555-0 Fax : +49-7157-989555-40

[www.nitto-kohki.eu/](http://www.nitto-kohki.eu/)

#### NITTO KOHKI EUROPE GMBH UK Branch

Unit A5, Langham Park Industrial Estate, Maple Road,

Castle Donington, Derbyshire DE74 2UT, United Kingdom

Tel : +44-1332-653800 Fax : +44-1332-987273

[www.nitto-kohki.eu/](http://www.nitto-kohki.eu/)

#### NITTO KOHKI CO., LTD. Bangkok Representative Office

2 Jasmine Building, 22nd Floor, Soi Prasarnmit(Sukhumvit23),

Sukhumvit Road, North Klongtoey, Wattana, Bangkok 10110, Thailand

Tel : +66-2612-7388

Thai [www.nitto-kohki.co.jp/network/th/](http://www.nitto-kohki.co.jp/network/th/)

Vietnamese [www.nitto-kohki.co.jp/network/vi/](http://www.nitto-kohki.co.jp/network/vi/)

#### NITTO KOHKI CO., LTD. India Liaison Office

3rd Floor, Building No.9-A DLF Cyber City, Phase-III,

Gurgaon, Haryana 122002, India

Tel : +91-124-454-5031 Fax : +65-6227-0192

[www.nitto-kohki.co.jp/network/](http://www.nitto-kohki.co.jp/network/)

#### NITTO KOHKI CO., LTD. Singapore Branch

18, Kaki Bukit Road 3, #02-12, Entrepreneur Business Centre, Singapore 415978

Tel : +65-6227-5360 Fax : +65-6227-0192

[www.nitto-kohki.co.jp/network/](http://www.nitto-kohki.co.jp/network/)

#### NITTO KOHKI CO., LTD. Indonesia Representative Office

Centennial Tower 35th Floor Jl. Jend. Gatot Subroto Kav. 24-25,

Jakarta 12930, Indonesia

Tel : +62-21-2953-9500

[www.nitto-kohki.co.jp/network/id/](http://www.nitto-kohki.co.jp/network/id/)

#### NITTO KOHKI AUSTRALIA PTY LTD

77 Brandl Street, Eight Mile Plains, Queensland 4113, Australia

Tel : +61-7-3340-4600 Fax : +61-73340-4640

[www.nitto-australia.com.au/](http://www.nitto-australia.com.au/)

#### NITTO KOHKI (SHANGHAI) CO., LTD.

Room1506, Suite C, Orient International Plaza,

No.85 Loushanguan Road, Shanghai 200336, China

Tel : +86-21-6415-3935 Fax : +86-21-6472-6957

[www.nitto-kohki.cn/](http://www.nitto-kohki.cn/)

#### NITTO KOHKI (SHANGHAI) CO., LTD. Shenzhen Branch

2005C Shenzhen ICC Tower, Fuhuasanlu 168,

Futian District, Shenzhen, Guangdong 518048, China

Tel : +86-755-8375-2185 Fax : +86-755-8375-2187

[www.nitto-kohki.cn/](http://www.nitto-kohki.cn/)

DISTRIBUTED BY